



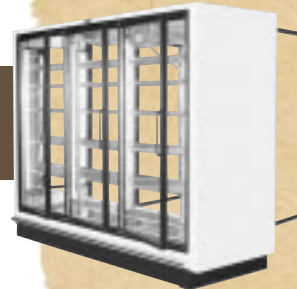
Display Coolers

INSTALLATION and OPERATING INSTRUCTIONS for



RMCP30 Series

Shop Around



Rear Load



RMCP24 Series





TABLE OF CONTENTS

SUBJECT	
GENERAL INFORMATION	1
INTRODUCTION	1
INSPECTION	1
LOCATION	1
INSTALLATION	1
LEVELING	1,3
JOINING COOLERS	3
DRAIN LINE	3
CART BUMPER	3
REFRIGERATION	5
GENERAL	5
REFRIGERANT PIPING	5
TEMPERATURE CONTROL	5-6
LEAK CHECK-EVACUATION-CHARGING	6
ELECTRICAL	6
DEFROSTING	6
USER INFORMATION	6
CLEANING	6
SHELF LOCATION	6
LANE DIVIDERS	7
SHELF GLIDES	7
PRE CUT SALAD RACK	7
FLORAL SHELVES	7
LOADING THE COOLER	8
LIGHT SWITCH	8
SERVICE	8
CART BUMPER	8
EVAPORATOR	8
EXPANSION VALVE	8
EVAPORATOR FANS	8
LIGHTS	9
BALLASTS	9
ALTERNATE LIGHTING - T8	9
CONDENSATE EVAPORATION SYSTEM	9



TABLES

TABLE 1 RMCP30/RMCP30RL LINE SIZE R22
TABLE 2 RMCP30SA LINE SIZE R22
TABLE 3 RMCP24 LINE SIZE R22

FIGURES

FIGURE 1 LEVELING CASES PRIOR TO JOINING
FIGURE 2 CAULKING CASES TO BE JOINED
FIGURE 3 JOINING 30" DOOR REACH-IN COOLERS
FIGURE 4 INSTALLING THE CART BUMPER
FIGURE 5 JOINING 30" DOOR REAR LOAD OR SHOP AROUND COOLERS
FIGURE 6 JOINING 24" DOOR REACH-IN COOLERS
FIGURE 7 INSTALLING TEE STRIPS
FIGURE 8 TEMPERATURE CONTROL SETTINGS
FIGURE 9 TYPICAL TEMPERATURE CONTROLS
FIGURE 10 LANE DIVIDERS
FIGURE 11 SALAD RACKS
FIGURE 12 SOCKET DETAIL
FIGURE 13 RMCP30 SPECIFICATION SHEET
FIGURE 14 RMCP30RL SPECIFICATION SHEET
FIGURE 15 RMCP30SA SPECIFICATION SHEET
FIGURE 16 RMCP24 SPECIFICATION SHEET
FIGURE 17 RMCP30/RMCP24 WIRING DIAGRAM

WARRANTY



GENERAL INFORMATION

Introduction

The information contained in this manual pertains to the following display coolers: RMCP30, RMCP30RL, RMCP30SA and RMCP24. These are used for merchandising refrigerated packaged food. The number 30 in the model number designate a case with 30" wide doors. The number 24 in the model number indicates 24" wide doors.

These display coolers are designed to operate in an air-conditioned store where the temperature is maintained at 75°F or lower and the relative humidity is 55% or lower.

RMCP30RL (REAR LOAD)

This case design allows product to be loaded through solid sliding doors at the rear of the case. The case is designed to have the back of case built into the wall of a cooler. The rear doors do not have lamps but are heated to prevent condensation. Detailed instructions can be found in the door manufacturer's instruction sheet.

RMCP30SA (SHOP AROUND)

This case design allows product to be shopped from either side. The evaporator fans face the front of the case. The main wiring compartment is located behind the kick plate in the front of the case. If ballasts are supplied by Zero Zone and not the door manufacturer, they will be located behind the kick plate.

Inspection

These display coolers were carefully inspected and properly packed to ensure delivery in the best possible condition. The equipment should be checked for damage immediately upon delivery. ALL CLAIMS FOR DAMAGES MUST BE FILED WITH THE TRANSPORTATION COMPANY - NOT WITH Zero Zone. The carrier will supply necessary report and claim forms.

Location

Do not locate this equipment where it will be exposed to the direct rays of the sun or near a source of radiant heat or airflow.

Be certain that the floor under the installation is of sufficient strength to prevent sagging. out of level conditions will result in reduced performance.

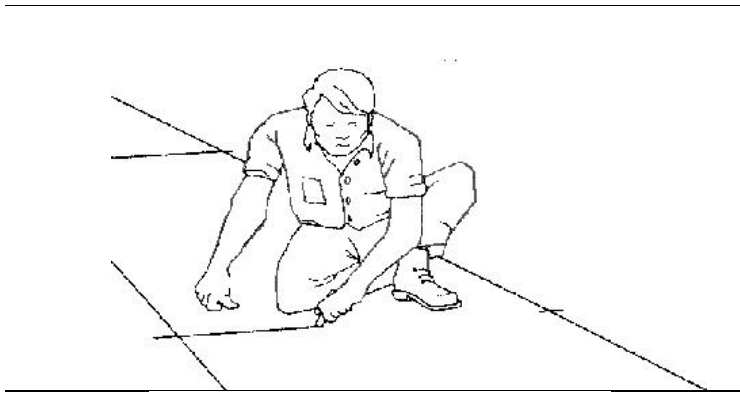
Wall cases, and back to back cases, should be positioned to allow a 1 - 4 inch space behind the back of a unit. This space will allow air to circulate behind the unit.

INSTALLATION

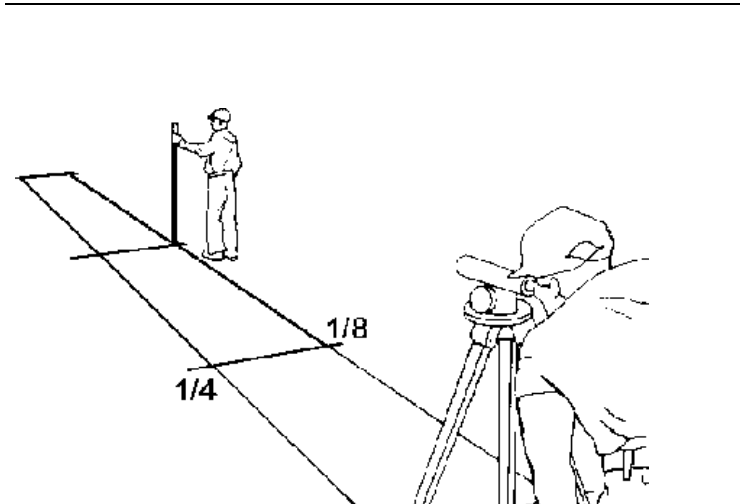
Leveling (See Figure 1)

Refrigeration equipment must be installed level to allow efficient operation of the refrigeration coils and complete drainage of defrost water. Since a level area is seldom available, the following steps are recommended to insure a level installation.

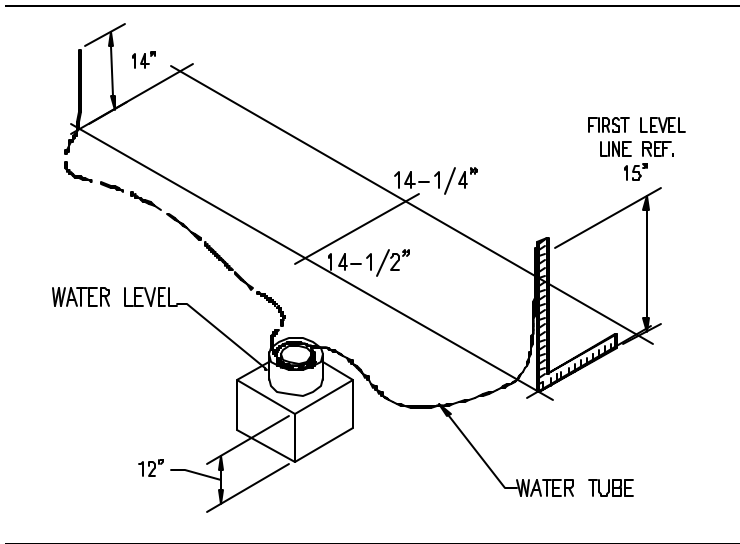
1. Measure off and mark on floor the exact dimensions of the case line-up. (Check blueprints).
2. Snap a chalk line at the locations for the front and back positions of the base rails.
3. Mark locations of all joints (front and back).
4. Using a transit, find the highest point along both base rail position lines. using the high point as a reference, mark the difference directly on the floor at each joint (front and back).
5. If a transit is not available, a water level can be used to mark reference elevation points. Water levels can be purchased from a contractor supply house for a minimal cost.
6. A string level can also be used to mark elevation points. The string level should only be used on short line-ups to avoid string sag.



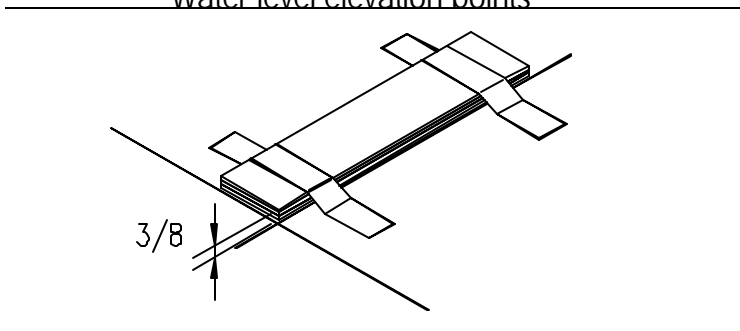
Measure and mark exact case



Mark floor level differences



Water level elevation points



Shim joints to equal highest points

Figure 1: Leveling cases prior to joining

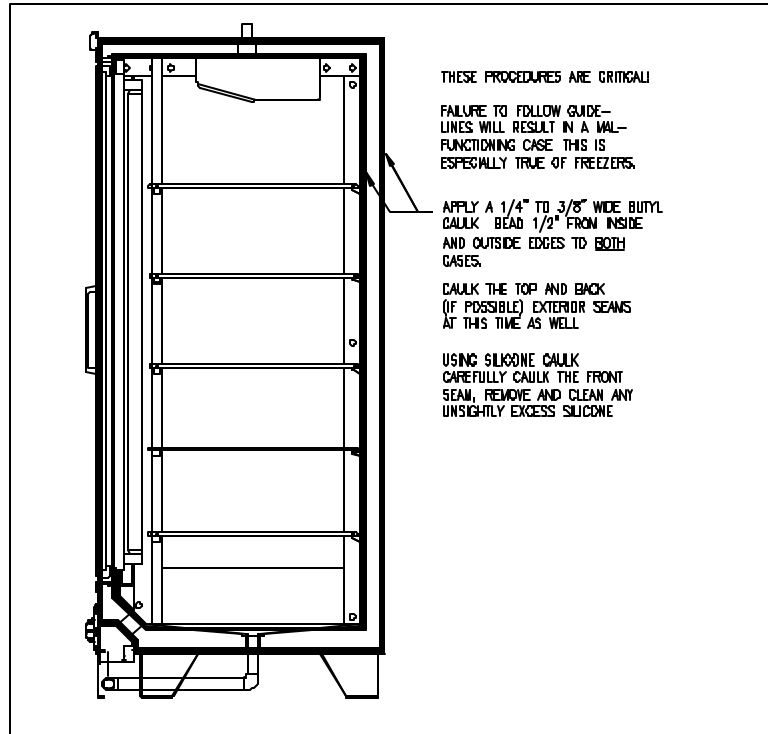


Figure 2: Caulking cases to be joined

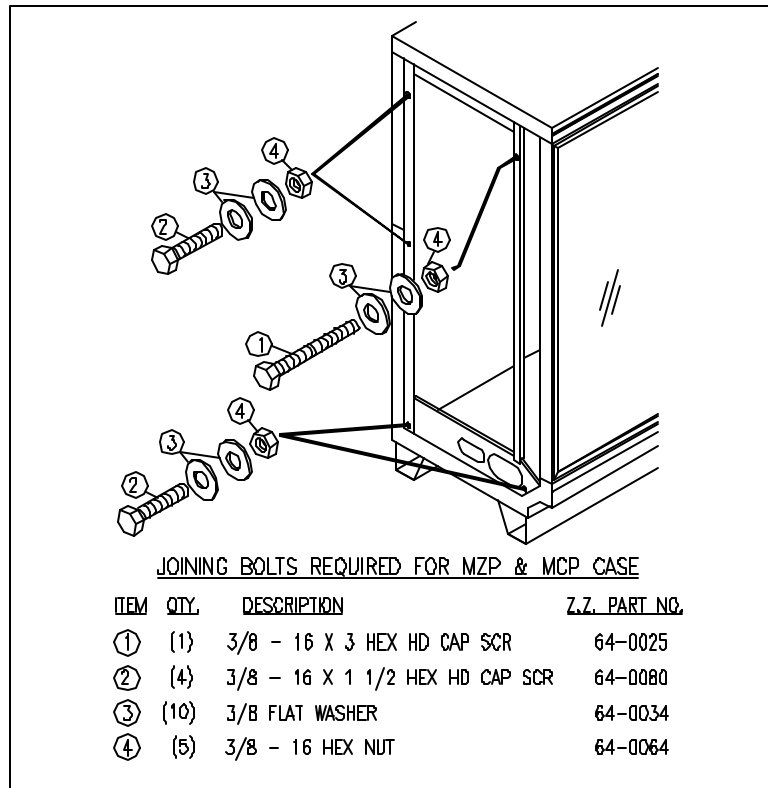


Figure 3: Joining 30" Door RMCP30 Reach-In Coolers



7. Place the required number of shims (supplied) at each joint (front and back) to equal the highest point. Tape all shims in place.
8. Place additional support shims at the center of four and five door case base rails (front and back).
9. Use a carpenter's level to check installation as you go. The case should be level from front to back and side to side. Install the case at the highest point first, if part of a line-up.

Joining Coolers

These reach-In coolers have been engineered for continuous display. This means that any number of cases can be joined together to create a display of any desired length. Reach-In coolers are built on permanent steel skids to promote easy installation. The cases can be moved on pipe rollers or with a Johnson Bar. The ends of the case are protected with a removable steel plate.

To install Reach-Ins, perform the following steps:

1. Set the first Reach-In into the desired position and level it. Run a 3/8-inch diameter bead of Butyl caulk ½ inch in from both the inner and outer surfaces of the case end. (See Figure 2)
2. Push the second Reach-In against the end of the first. Level the second Reach-In. See Figure 3 for 30" Door cases; Figure 5 for 30" Door Reach-In Rear Load and Shop Around cases; and Figure 6 for 24" Door Reach-In Coolers. Install tee strips between the door frames at case joints on 30" door cases (See Figure 7). Use the special screws and nuts provided.
3. Start the joining bolts, but do not tighten them. Begin tightening the bolts at the top rear, working down the back of the case and up the front making sure that the front seams are flush.

Drain Line

Condensate water drains from the evaporator through a plastic hose mounted at the rear of the case. The tubing should be free of kinks and dirt so water drains freely. The case drain is located at the center of the cooler in the floor pan. The 1 inch PVC drain outlet is located at the center front of the cooler behind the kick plate.

The tee, drain trap, and plug are supplied standard with the case. Install a tee to the outlet pipe and a PVC drain trap to the tee. Plug the open end of the tee using the clean-out plug supplied with the drain trap kit. The drain line must be pitched away from the case a minimum of 1/4 inch per foot.

Cart Bumper

The cart bumper should be installed at the bottom front of the case. (See Figure 4) The assembly is adjustable to compensate for uneven floors.

Center and hook the bumper assembly on the hanger provided.

In continuous line-ups, place a kick plate joint strip at each joint. On case ends, lineup the end kick plate with the front mounting holes. Fasten the rear of the end kick plate to the case using self drilling (TECH) screws.

Slide the front kick plate behind the bumper assembly and in front of the end kick plate or kick plate joint strip. Install three screws (two screws on 2-door only) to hold the kick plate and bumper in place. The screws attach the kickplate to a bracket with a speed nut (timmerman clip).

A bumper joint strip can be installed over the bumper at the joints. This is standard on the Euro Style bumper.

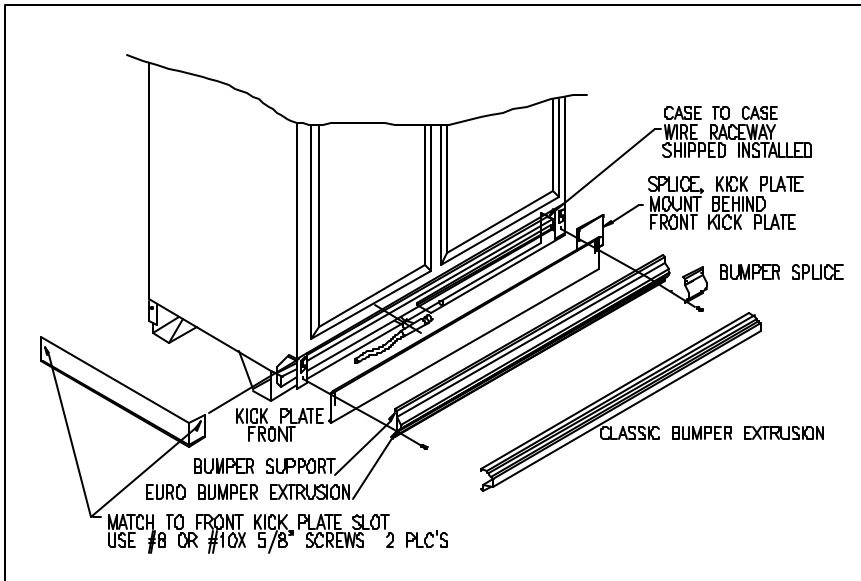


Figure 4: Installing The Cart Bumper

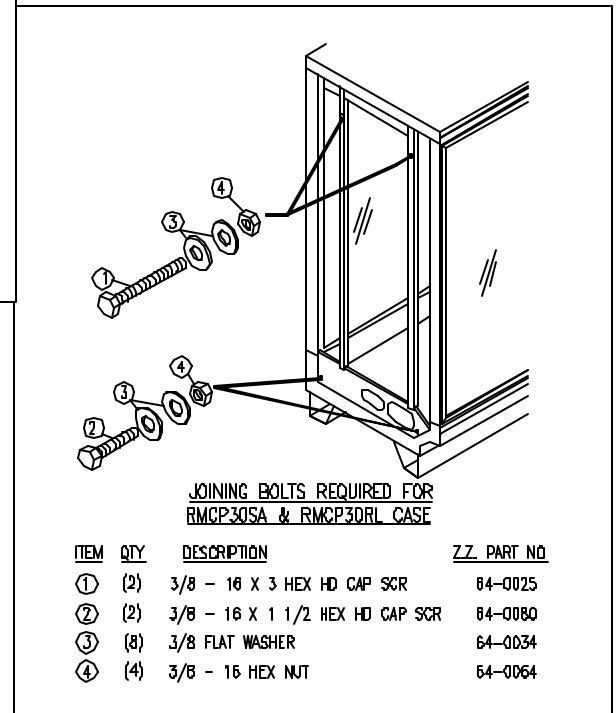


Figure 5: Joining 30" Door Rear Load or Shop Around Reach-In Coolers

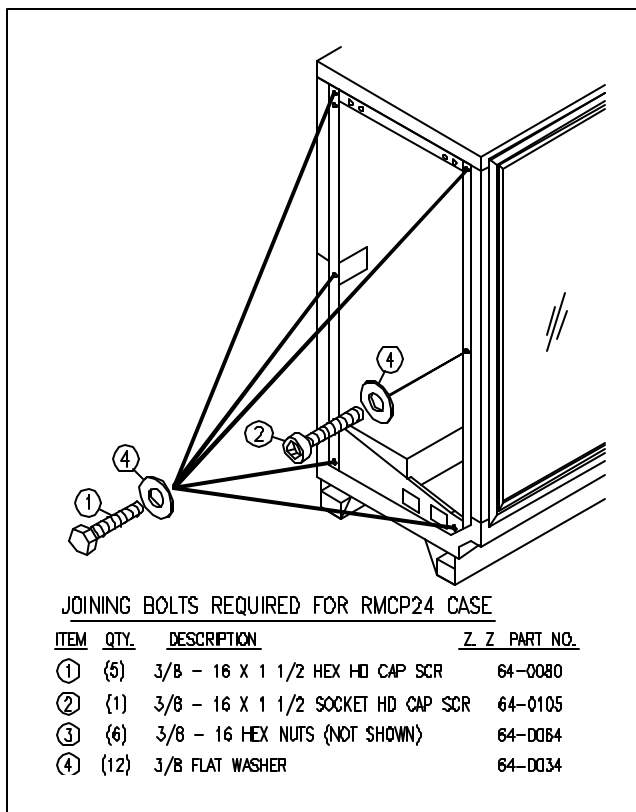


Figure 6: Joining 24" Door Reach-In Coolers

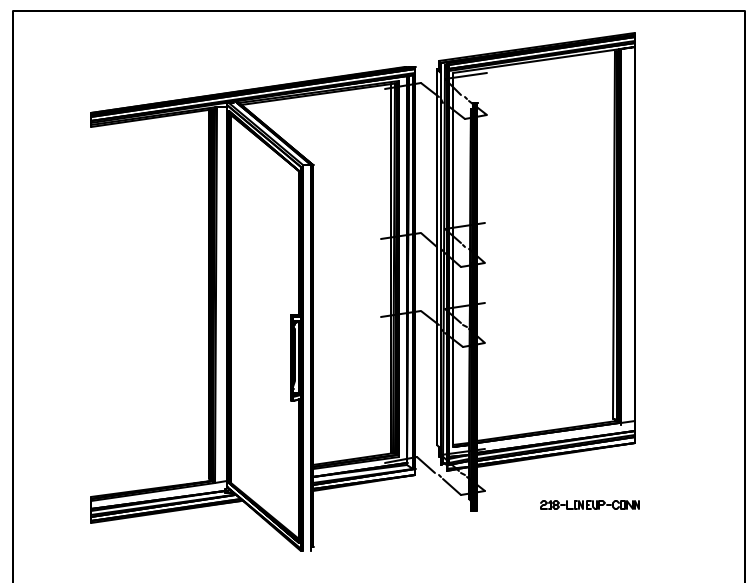


Figure 7: Installing Tee Strips

RMCP30, RMCP30RL, RMCP30SA, RMCP24



REFRIGERATION

General

Unless otherwise specified, the liquid and suction connections are made on top of the case. (Figures 13-16.) Alternate locations are out the back of case. After connections are made, the refrigeration access hole in the cooler must be sealed completely with aerosol-dispensed Urethane insulation or equivalent.

Refrigerant Piping

Correct refrigeration line sizing and installation is essential for proper system operation. The following tables (Tables 1 -3) list R-22 line sizes for different combinations of coolers. A P-trap must be installed at the bottom of all vertical suction risers.

The compressor should be installed as close as possible to the coolers to reduce pressure drop. If the compressor is located above the cooler, use one size smaller tube for the suction tube riser only and install a shallow trap at the bottom of the riser. Use a flexible connection (vibration eliminator) between the suction line and compressor.

The suction and liquid lines may be taped together to form an external heat exchanger. Insulate the tubing for at least 20 feet from the cooler outlet.

A liquid line drier should be installed. Install a moisture indicating sight glass at the outlet end of the drier.

	TIME CLOCK DEFROST PRODUCT 41° F TO 37° F	
	Pressure (psig)	RETURN AIR TEMP.
	R-22	
Cut In	64	37° F
Cut Out	40	33° F
	OFF CYCLE DEFROST PRODUCT 41° F TO 37° F	
	Pressure (psig)	RETURN AIR TEMP.
	R-22	
Cut In	68	40° F
Cut Out	42	34° F

Figure 8: Temperature Control

Temperature Control

A low pressure or temperature control located to sense return air can be used to control cooler temperature. The control should be selected with adequate contact capacity for the switching load. In rack systems, an evaporator pressure-regulating valve may be used to control the evaporating temperature.

The settings (See Figure 8) are approximate due to variations in gauge accuracy, differences in compressor efficiency, and line pressure drop. These should be adjusted as store or stocking conditions change.

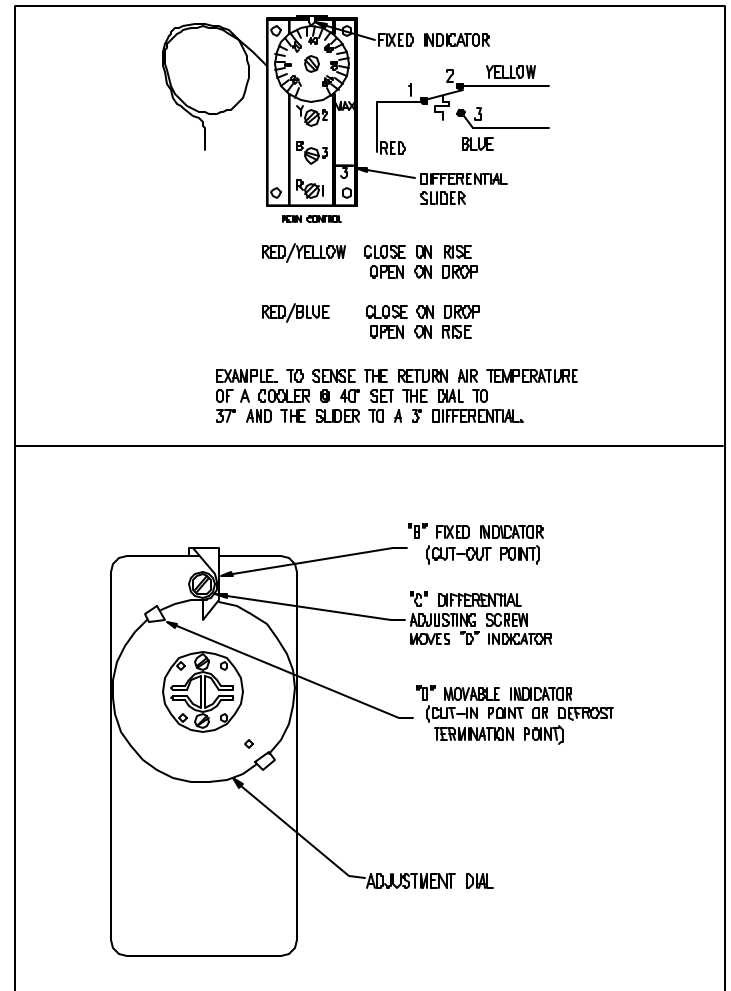


Figure 9: Typical Temperature Controls



Temperature Control Adjustment

When factory installed, the temperature control is located on top of the cooler. The sensing bulb is located under the coil cover in front of the coil. (Figure 9 shows typical temperature controls).

Leak Check-Evacuation-Charging

After all of the refrigeration piping and system components have been assembled, the entire system must be pressurized and checked for leaks. Use nitrogen and refrigerant vapor to check for leaks. A Halide leak detector or an electronic leak detector is recommended.

If the system is sealed, evacuate with a high vacuum pump. Triple evacuation to a minimum of 500 microns and nitrogen sweep is recommended. After the system has been thoroughly evacuated of all moisture and non-condensable gas, charge the system with the proper refrigerant, using "hi-side/low-side" charging techniques.

ELECTRICAL

Figure 17 shows the typical wiring diagram for a cooler. Each case is provided with a wiring diagram located in the electric box that shows the exact wiring of the case.

External wiring should be sized according to the amperage rating stamped on the serial plate. The serial plate is located on the ceiling inside the left-hand door. Typical electrical values are shown in Figures 13-16. All internal wiring has been done at the factory, and has been terminated in the electrical compartment located behind the kick rail at the right end of the case. The temperature control mounted on top of the case is not wired. A terminal block has been used to simplify field connections.

The fan circuit is energized at all times. The light and anti-condensate circuit may be cycled off during defrost. If a time clock is used, it is in operation at all times.

Note: All wiring must comply with the National Electrical Code and all local codes.

DEFROSTING

Periodic defrosting to keep the coil free of frost is accomplished either automatically by a time clock or with compressor off cycle defrost. The most reliable defrost system uses a time clock that turns off the refrigeration cycle once per day for 60 minutes. A time clock can be purchased from Zero Zone or from a local refrigeration supply house.

When only OFF cycle defrost is used, the compressor must be sized large enough to allow for periodic off cycles. When the compressor shuts off, the evaporator fans continue to run. This allows the coil to defrost. The cut-in set point for the compressor should be not lower than 40°F when OFF cycle defrost is used.

USER INFORMATION

Cleaning

The cooler should be thoroughly cleaned before start-up and routinely thereafter to maintain a clean appearance. Use mild detergent and warm water (never an abrasive cleaner) to wipe out the inside of the cooler. Wash down all glass doors with glass cleaner. The cooler will remain bright and sparkling with just a few minutes of cleaning each week. The case drain should be regularly cleared of debris and price tags

Note: Do not use high-pressure water or steam to clean the interior.

Shelf Location

The shelves are adjustable in 1/2-inch increments. They may be located in any position for best display

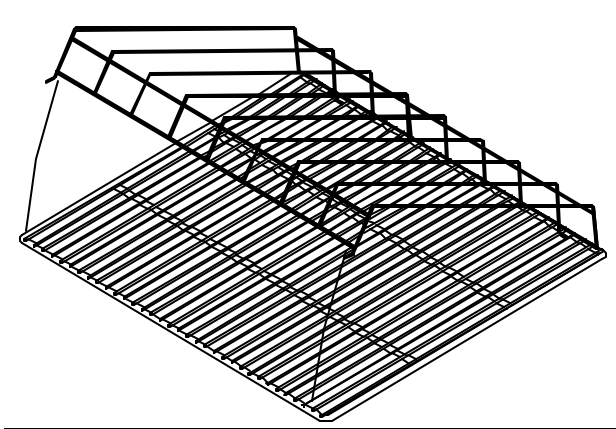


Figure 10: Lane Dividers

advantage. due to the air discharge arrangement, it is suggested that the uppermost shelf be placed 11 inches down from the ceiling. Place the remaining shelves approximately 10 1/2 inches apart.

Be sure shelf clips or brackets are completely seated before installing the shelf.

Lane Dividers (RMCP30 Only)

Lane dividers with 2-7/8 inch, 3-1/4 inch, 3-3/4 inch, or 4-3/4 inch wide lanes are available for use on the shelves. The rear of the lane divider has the shelf hooks inset from the end. The lane divider is installed by hooking the rear hooks under the large shelf wire (See Figure 10). Flex the lane divider and hook the wire under the large front shelf wire.

Shelf Glides (RMCP30 Only)

Shelf glides are available for use with lane dividers. This helps the product gravity feed to the front of the case.

Pre Cut Salad Rack

The rear of the rack has two feet that slip under the shelf wires. The rear of the rack also has a raised wire stop. The stop is used to provide an air gap between the product and rear wall.

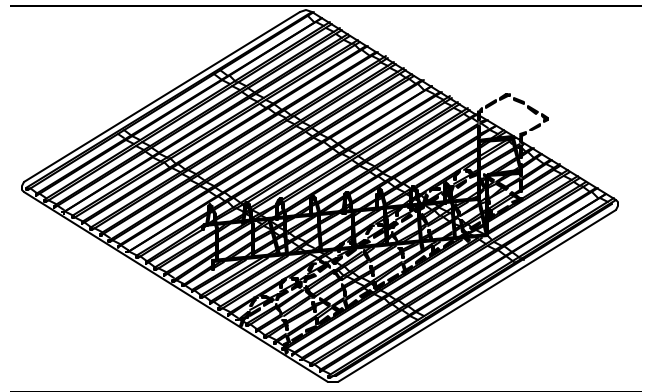


Figure 11: Salad Rack

The rack is installed as follows:

1. Set the rack on top of the shelf.
2. Rotate the rack 45 degrees to the side.
3. Slide both rear feet under the shelf wires.
4. Rotate the salad rack back to the original position while keeping the rear feet under the wires.
5. Gently squeeze the front of the rack and slide the two feet between the shelf wires (See Figure 11).

Floral Shelves (RMCP30 Only)

Glass cantilever floral shelves are available. The shelves rest on special extra wide shelf brackets.

Cantilever floral bucket shelves are also available. The bucket shelf bracket is adjustable to allow for shelf tilting. Before attempting to adjust the shelf bracket, follow these steps:

1. Remove the shelf.
2. Remove the set screw from the side of the bracket.
3. Rotate the bracket to the new position.
4. Install the set screw.

Cantilever shelf standards are factory installed and must be ordered with a new case.



Loading the Cooler

The cooler may be loaded with merchandise after it has been operated for at least 24 hours with correct case temperature and proper control operation. While loading the shelves, leave at least 1 1/2 inch between the top of the merchandise and the shelf above it so the customer can remove the merchandise. Leave a 1 1/2-inch air gap at the rear of the case. This allows cool air to travel down the back of the product and return to the evaporator at the front of the case. The 1 1/2-inch space allows an air curtain on the top of the product.

Light Switch

The light switch is located on the mullion or upper right corner of the doorframe. **Always turn the lights off when replacing lamps.**

SERVICE

Cart Bumper

The cart bumper must be removed to gain access to the drain connection and electrical connection. Disassemble the bumper and black kick plate by removing the 2 or 3 metal screws located in the kick plate. The bumper assembly can be lifted up and removed from the case. The kick plate can be removed, exposing the electrical connection and drain outlet. (Figure 4 shows the bumper assembly)

Evaporator

The evaporator coil, located at the ceiling of the cooler, is factory assembled with an expansion valve. To inspect the coil, the coil cover can be removed as follows:

Loosen two screws on the underside of the coil cover until the forward edge drops down exposing the evaporator coil and fan assemblies.

While supporting the cover, unplug the fan electrical connection from main coil housing.

Expansion Valve

A thermostatic expansion valve with a "C" charge, adjustable superheat and thermal bulb is mounted to the evaporator coil. Under certain conditions, it may be necessary to adjust the superheat setting for maximum coil effectiveness. Typical superheat settings are between 10°F and 15°F. To adjust the expansion valve, remove the coil cover. Remove the cap from the bottom of the valve. When looking at the valve stem end, turn the valve stem counterclockwise to decrease superheat. Turn the valve stem clockwise to increase super heat. Measure the suction line temperature at the expansion valve-sensing bulb and compare it to the suction temperature corresponding to the saturated pressure. Make sure that line pressure drop is taken into account.

Turn the valve stem only 1/4 turn at a time and allow sufficient time (20 to 30 minutes) for the valve to settle before making any further adjustments. Replace the valve stem cap after the valve super-heat has been adjusted. **BE CERTAIN THE VALVE STEM CAP IS WIPED DRY FIRST.**

! CAUTION !

**DISCONNECT POWER TO THE CASE BEFORE
SERVICING ELECTRICAL COMPONENTS**

Evaporator Fans

Air is circulated throughout the cooler with shaft down, 115-volt medium temperature fan motors. These motors must be operating at all times. The fans are mounted on the evaporator coil cover. To service the fans, they are accessed by removal of the coil cover as described under SERVICE/EVAPORATOR.



Lights

high output 800 milliamp lamps are standard. To ensure maximum component life, always replace with 800 milliamp lamps. Use retainer clips and lamp shields.

To change a lamp, turn off the light switch and remove the retainer clip located between the top socket and end cap. Carefully push the lamp up into the spring-loaded lamp socket to allow the lamp to be removed from the bottom socket. (See Figure 12.) Remove the end caps and shield. **All lamps must use end caps and shields.**

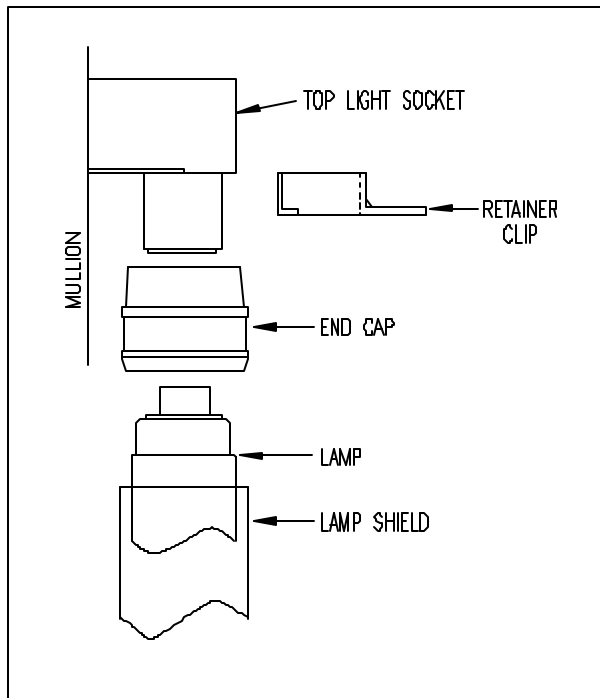


Figure 12: Socket Detail

Ballast

Zero Zone cooler ballasts are located either behind the kick plate or in the door mullions.

Alternate Lighting -T8

T-8 lighting is standard on the 30" door case and optional on the 24" door coolers. Many door manufacturers provide premium lighting systems. These systems use a lens to direct light output evenly across

the shelves. The lens must be removed to access the lamp. Ardc's lamp may be removed by turning it 90 degrees and sliding the lamp pins out of the lamp socket slot. The lens must be installed over the lamp. Anthony's lamp is removed by sliding the end caps off of the lamp. Detailed information is contained in the door instruction booklet.

Condensate Evaporation System

Zero Zone remote cases can be equipped with an automatic condensate evaporation system. The system uses a pump and drain pan located behind the kick plate and a condensate evaporator pan mounted on the top of the case.

Condensate water and any liquid spilled in the case drain out into the drain pan. The pump is equipped with a float that turns the pump on when there is a sufficient liquid level. Liquid is pumped through a plastic hose through a check valve and into the condensate-evaporating pan. The evaporating pan is equipped with a heater and a float switch to turn on when the heater is submerged in liquid. When the heater is energized the pan will be extremely hot and should not be touched.

The pump and condensate pan should be cleaned regularly. Any spilled product should be cleaned to prevent odors.



Table 1

REMOTE REACH-IN COOLER W/ 30" X 63" DOORS MODEL RMCP30 & RMCP30RL REFRIGERANT R-22 @ 20° F EVAPORATOR									
NO. OF DOORS	FREEZER COMBINATIONS	TOTAL LENGTH W/ENDS	BTU/HR	RECOMMENDED LIQUID LINE SIZES EQUIVALENT LENGTH, FEET			RECOMMENDED SUCTION LINE SIZES EQUIVALENT LENGTH, FEET		
				50	100	150	50	100	150
2	(1) 2-DR	5'-7 1/16"	2,735	3/8	3/8	3/8	1/2	1/2	1/2
3	(1) 3-DR	8'-1 1/2"	3,705	3/8	3/8	3/8	1/2	1/2	5/8
4	(1) 4-DR	10'-7 15/16"	4,650	3/8	3/8	3/8	1/2	5/8	5/8
5	(1) 5-DR	13'-2 3/8"	5,625	3/8	3/8	3/8	1/2	5/8	5/8
6	(2) 3-DR	15'-10"	6,750	3/8	3/8	3/8	5/8	5/8	7/8
7	(1) 3-DR & (1) 4-DR	18'-4 7/16"	7,875	3/8	3/8	3/8	5/8	5/8	7/8
8	(2) 4-DR	20'-10 7/8"	9,000	3/8	3/8	3/8	5/8	7/8	7/8
9	(1) 4-DR & (1) 5-DR	23'-5 5/16"	10,125	3/8	3/8	3/8	5/8	7/8	7/8
10	(2) 5-DR	25'-11 3/4"	11,250	3/8	3/8	3/8	5/8	7/8	7/8
11	(1) 3-DR & (2) 4-DR	28'-7 3/8"	12,375	3/8	3/8	3/8	7/8	7/8	7/8
12	(3) 4-DR	31'-1 13/16"	13,500	3/8	3/8	3/8	7/8	7/8	7/8
13	(2) 4-DR & (1) 5-DR	33'-8 1/4"	14,625	3/8	3/8	3/8	7/8	7/8	7/8
14	(1) 4-DR & (2) 5-DR	36'-2 11/16"	15,750	3/8	3/8	3/8	7/8	7/8	7/8
15	(3) 5-DR	38'-9 1/8"	16,875	3/8	3/8	1/2	7/8	7/8	7/8
16	(4) 4-DR	41'-4 3/4"	18,000	3/8	3/8	1/2	7/8	7/8	1 1/8
17	(3) 4-DR & (1) 5-DR	43'-11 3/16"	19,125	3/8	3/8	1/2	7/8	7/8	1 1/8
18	(2) 4-DR & (2) 5-DR	46'-5 5/8"	20,250	3/8	3/8	1/2	7/8	7/8	1 1/8
19	(1) 4-DR & (3) 5-DR	49'-1 1/16"	21,375	3/8	1/2	1/2	7/8	7/8	1 1/8
20	(4) 5-DR	51'-6 1/2"	22,500	3/8	1/2	1/2	7/8	1 1/8	1 1/8
21	(4) 4-DR & (1) 5-DR	54'-2 1/8"	23,625	3/8	1/2	1/2	7/8	1 1/8	1 1/8
22	(3) 4-DR & (2) 5-DR	56'-8 9/16"	24,750	3/8	1/2	1/2	7/8	1 1/8	1 1/8
23	(2) 4-DR & (3) 5-DR	59'-3"	25,875	3/8	1/2	1/2	7/8	1 1/8	1 1/8
24	(1) 4-DR & (4) 5-DR	61'-9 7/16"	27,000	3/8	1/2	1/2	7/8	1 1/8	1 1/8
25	(5) 5-DR	64'-3 7/8"	28,125	3/8	1/2	1/2	7/8	1 1/8	1 1/8
26	(4) 4-DR & (2) 5-DR	66'-11 1/2"	29,250	1/2	1/2	1/2	7/8	1 1/8	1 1/8
27	(3) 4-DR & (3) 5-DR	69'-5 15/16"	30,375	1/2	1/2	1/2	7/8	1 1/8	1 1/8
28	(2) 4-DR & (4) 5-DR	72'-3/8"	31,500	1/2	1/2	5/8	7/8	1 1/8	1 1/8
29	(1) 4-DR & (5) 5-DR	74'-6 13/16"	32,625	1/2	1/2	5/8	1 1/8	1 1/8	1 1/8
30	(6) 5-DR	77'-1 1/4"	33,750	1/2	1/2	5/8	1 1/8	1 1/8	1 1/8

NOTE: BTU/HR RATING BASED ON 800 MA T-12 LIGHTING AND PARALLEL RACK SYSTEM. MULTIPLY BY 1.04 FOR CONVENTIONAL SYSTEM. DEDUCT 30 BTU/DOOR FOR T-8 ELECTRONIC LIGHTING SYSTEM. CASES DESIGNED TO OPERATE IN AN AMBIENT OF 75°F OR LOWER AND RELATIVE HUMIDITY 0



Table 2

REMOTE REACH-IN COOLER W/ 30" X 63" DOORS MODEL RMCP30SA REFRIGERANT R-22 @ 20° F EVAPORATOR									
NO. OF DOORS	FREEZER COMBINATIONS	TOTAL LENGTH W/ENDS	BTU/HR	RECOMMENDED LIQUID LINE SIZES EQUIVALENT LENGTH, FEET			RECOMMENDED SUCTION LINE SIZES EQUIVALENT LENGTH, FEET		
				50	100	150	50	100	150
2	(1) 2-DR	5'-7 1/16"	4,785	3/8	3/8	3/8	1/2	5/8	5/8
3	(1) 3-DR	8'-1 1/2"	6,485	3/8	3/8	3/8	5/8	5/8	5/8
4	(1) 4-DR	10'-7 15/16"	8,140	3/8	3/8	3/8	5/8	5/8	7/8
5	(1) 5-DR	13'-2 3/8"	9,845	3/8	3/8	3/8	5/8	7/8	7/8
6	(2) 3-DR	15'-10"	11,814	3/8	3/8	3/8	5/8	7/8	7/8
7	(1) 3-DR & (1) 4-DR	18'-4 7/16"	13,783	3/8	3/8	3/8	7/8	7/8	7/8
8	(2) 4-DR	20'-10 7/8"	15,752	3/8	3/8	3/8	7/8	7/8	7/8
9	(1) 4-DR & (1) 5-DR	23'-5 5/16"	17,721	3/8	3/8	1/2	7/8	7/8	1 1/8
10	(2) 5-DR	25'-11 3/4"	19,690	3/8	3/8	1/2	7/8	7/8	1 1/8
11	(1) 3-DR & (2) 4-DR	28'-7 3/8"	21,659	3/8	1/2	1/2	7/8	7/8	1 1/8
12	(3) 4-DR	31'-1 13/16"	23,628	3/8	1/2	1/2	7/8	1 1/8	1 1/8
13	(2) 4-DR & (1) 5-DR	33'-8 1/4"	25,597	3/8	1/2	1/2	7/8	1 1/8	1 1/8
14	(1) 4-DR & (2) 5-DR	36'-2 11/16"	27,566	3/8	1/2	1/2	7/8	1 1/8	1 1/8
15	(3) 5-DR	38'-9 1/8"	29,535	3/8	1/2	1/2	7/8	1 1/8	1 1/8
16	(4) 4-DR	41'-4 3/4"	31,504	1/2	1/2	5/8	7/8	1 1/8	1 1/8
17	(3) 4-DR & (1) 5-DR	43'-11 3/16"	33,473	1/2	1/2	5/8	1 1/8	1 1/8	1 1/8
18	(2) 4-DR & (2) 5-DR	46'-5 5/8"	35,442	1/2	1/2	5/8	1 1/8	1 1/8	1 3/8
19	(1) 4-DR & (3) 5-DR	49'-1 1/16"	37,411	1/2	1/2	5/8	1 1/8	1 1/8	1 3/8
20	(4) 5-DR	51'-6 1/2"	39,380	1/2	5/8	5/8	1 1/8	1 1/8	1 3/8
21	(4) 4-DR & (1) 5-DR	54'-2 1/8"	41,349	1/2	5/8	5/8	1 1/8	1 1/8	1 3/8
22	(3) 4-DR & (2) 5-DR	56'-8 9/16"	43,318	1/2	5/8	5/8	1 1/8	1 1/8	1 3/8
23	(2) 4-DR & (3) 5-DR	59'-3"	45,287	1/2	5/8	5/8	1 1/8	1 3/8	1 3/8
24	(1) 4-DR & (4) 5-DR	61'-9 7/16"	47,256	1/2	5/8	5/8	1 1/8	1 3/8	1 3/8
25	(5) 5-DR	64'-3 7/8"	49,225	1/2	5/8	5/8	1 1/8	1 3/8	1 3/8
26	(4) 4-DR & (2) 5-DR	66'-11 1/2"	51,194	1/2	5/8	5/8	1 1/8	1 3/8	1 3/8
27	(3) 4-DR & (3) 5-DR	69'-5 15/16"	53,163	1/2	5/8	5/8	1 1/8	1 3/8	1 3/8
28	(2) 4-DR & (4) 5-DR	72'-3/8"	55,132	1/2	5/8	5/8	1 1/8	1 3/8	1 3/8
29	(1) 4-DR & (5) 5-DR	74'-6 13/16"	57,101	1/2	5/8	5/8	1 1/8	1 3/8	1 3/8
30	(6) 5-DR	77'-1 1/4"	59,070	5/8	5/8	7/8	1 1/8	1 3/8	1 3/8

NOTE: BTU/HR RATING BASED ON 800 MA T-12 LIGHTING AND PARALLEL RACK SYSTEM. MULTIPLY BY 1.04 FOR CONVENTIONAL SYSTEM. DEDUCT 30 BTU/DOOR FOR T-8 ELECTRONIC LIGHTING SYSTEM. CASES DESIGNED TO OPERATE IN AN AMBIENT OF 75°F OR LOWER AND RELATIVE HUMIDITY 0



Table 3

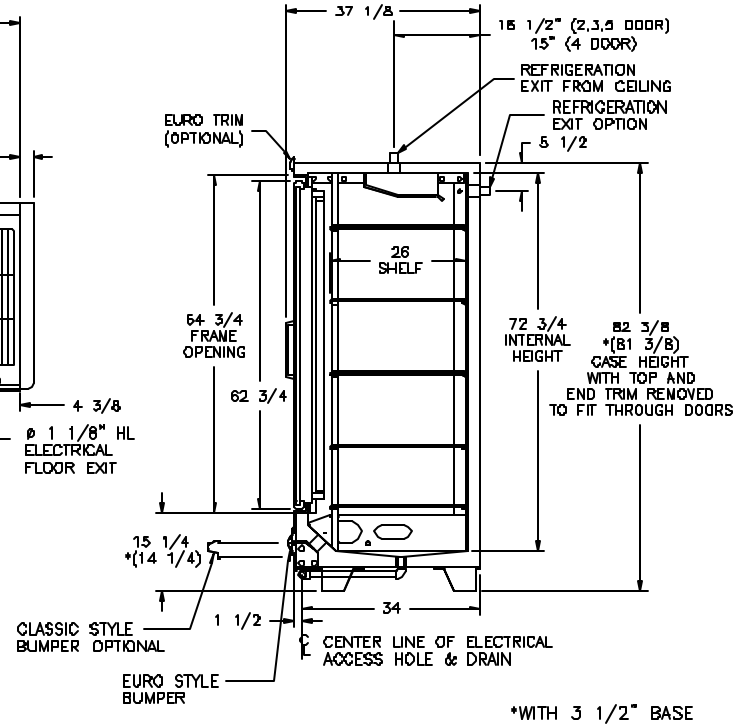
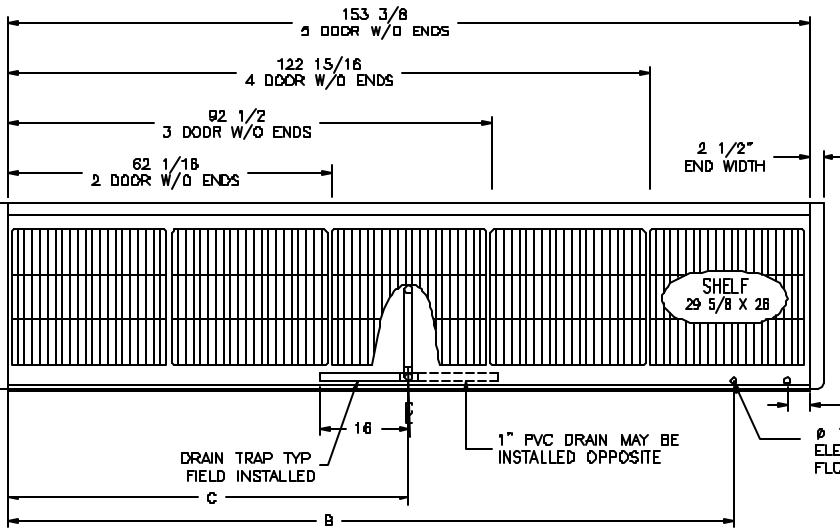
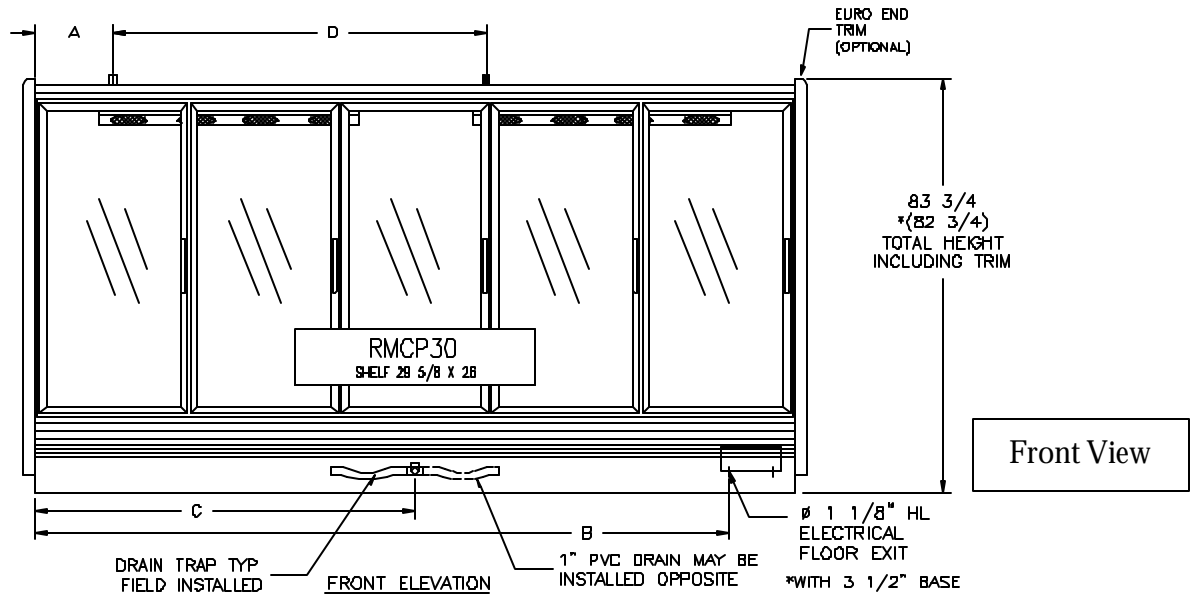
REMOTE REACH-IN COOLER W/ 24" X 63" DOORS MODEL RMCP24 REFRIGERANT R-22 @ 20° F EVAPORATOR									
NO. OF DOORS	FREEZER COMBINATIONS	TOTAL LENGTH W/ENDS	BTU/HR	RECOMMENDED LIQUID LINE SIZES EQUIVALENT LENGTH, FEET			RECOMMENDED SUCTION LINE SIZES EQUIVALENT LENGTH, FEET		
				50	100	150	50	100	150
2	(1) 2-DR	4'-8 7/8"	2,515	3/8	3/8	3/8	1/2	1/2	1/2
3	(1) 3-DR	6'-8 5/8"	3,355	3/8	3/8	3/8	1/2	1/2	1/2
4	(1) 4-DR	8'-8 3/8"	4,180	3/8	3/8	3/8	1/2	1/2	5/8
5	(1) 5-DR	10'-8 1/8"	4,965	3/8	3/8	3/8	1/2	5/8	5/8
6	(2) 3-DR	13'-1/4"	5,958	3/8	3/8	3/8	1/2	5/8	5/8
7	(1) 3-DR & (1) 4-DR	15'-0"	6,951	3/8	3/8	3/8	5/8	5/8	7/8
8	(2) 4-DR	16'-11 3/4"	7,944	3/8	3/8	3/8	5/8	5/8	7/8
9	(1) 4-DR & (1) 5-DR	18'-11 1/2"	8,937	3/8	3/8	3/8	5/8	7/8	7/8
10	(2) 5-DR	20'-11 1/4"	9,930	3/8	3/8	3/8	5/8	7/8	7/8
11	(1) 3-DR & (2) 4-DR	22'-10 3/8"	10,923	3/8	3/8	3/8	5/8	7/8	7/8
12	(3) 4-DR	25'-3 1/4"	11,916	3/8	3/8	3/8	5/8	7/8	7/8
13	(2) 4-DR & (1) 5-DR	27'-2 7/8"	12,909	3/8	3/8	3/8	7/8	7/8	7/8
14	(1) 4-DR & (2) 5-DR	29'-2 5/8"	13,902	3/8	3/8	3/8	7/8	7/8	7/8
15	(3) 5-DR	31'-2 3/8"	14,895	3/8	3/8	3/8	7/8	7/8	7/8
16	(4) 4-DR	33'-6 1/2"	15,888	3/8	3/8	3/8	7/8	7/8	7/8
17	(3) 4-DR & (1) 5-DR	35'-6 1/4"	16,881	3/8	3/8	1/2	7/8	7/8	7/8
18	(2) 4-DR & (2) 5-DR	37'-6"	17,874	3/8	3/8	1/2	7/8	7/8	1 1/8
19	(1) 4-DR & (3) 5-DR	39'-5 3/4"	18,867	3/8	3/8	1/2	7/8	7/8	1 1/8
20	(4) 5-DR	41'-1/2"	19,860	3/8	3/8	1/2	7/8	7/8	1 1/8
21	(4) 4-DR & (1) 5-DR	43'-9 5/8"	20,853	3/8	1/2	1/2	7/8	7/8	1 1/8
22	(3) 4-DR & (2) 5-DR	45'-9 3/8"	21,846	3/8	1/2	1/2	7/8	1 1/8	1 1/8
23	(2) 4-DR & (3) 5-DR	47'-9 1/8"	22,839	3/8	1/2	1/2	7/8	1 1/8	1 1/8
24	(1) 4-DR & (4) 5-DR	49'-8 7/8"	23,832	3/8	1/2	1/2	7/8	1 1/8	1 1/8
25	(5) 5-DR	51'-8 5/8"	24,825	3/8	1/2	1/2	7/8	1 1/8	1 1/8
26	(4) 4-DR & (2) 5-DR	54'-3/4"	25,818	3/8	1/2	1/2	7/8	1 1/8	1 1/8
27	(3) 4-DR & (3) 5-DR	56'-1/2"	26,811	3/8	1/2	1/2	7/8	1 1/8	1 1/8
28	(2) 4-DR & (4) 5-DR	58'-1/4"	27,804	3/8	1/2	1/2	7/8	1 1/8	1 1/8
29	(1) 4-DR & (5) 5-DR	60'-0"	28,797	3/8	1/2	1/2	7/8	1 1/8	1 1/8
30	(6) 5-DR	61'-11 3/4"	29,790	3/8	1/2	1/2	7/8	1 1/8	1 1/8

NOTE: BTU/HR RATING BASED ON 800 MA T-12 LIGHTING AND PARALLEL RACK SYSTEM. MULTIPLY BY 1.04 FOR CONVENTIONAL SYSTEM. DEDUCT 30 BTU/DOOR FOR T-8 ELECTRONIC LIGHTING SYSTEM. CASES DESIGNED TO OPERATE IN AN AMBIENT OF 75°F OR LOWER AND RELATIVE HUMIDITY 0



PRELIMINARY

RMCP30 SPECIFICATION SHEET



* NOTE: CASE DIMENSIONS SHOWN REFLECT STANDARD 4-1/2" HIGH BASES
DIMENSIONS SHOWN IN (PARENTHESIS) REFLECT 3-1/2" BASES.

Zero Zone Inc. • 110 N. Oakridge Dr.
North Prairie, WI 53153-9792
1-800-247-4496 • FAX: 1-262-392-6450
www.zero-zone.com

All specifications are subject to change without notice.



PRELIMINARY

RMCP30 SPECIFICATION SHEET

ELECTRICAL CONNECTION (B) & DRAIN (C) LOCATION SCHEDULE		
MODEL NUMBER	B	C
2RMCP30	48 5/8	31
3RMCP30	79 1/16	46 1/4
4RMCP30	109 1/2	61 1/2
5RMCP30	139 15/16	76 11/16

RMCP30 CAPACITY SPECIFICATIONS			
CASE SIZE	SHELVING 29-5/8X 26"	CUBIC FEET CAPACITIES	WEIGHT*
	GROSS SQ. FT.	GROSS CUBIC FT.	POUNDS
2	53.50	66.0	575
3	80.25	98.3	873
4	107.00	130.6	1128
5	133.75	163.0	1440

WEIGHT BASED ON UNCRATED CASES WITHOUT ENDS, AND FULLY SHELVED.
SINGLE END WEIGHT: 54#

REFRIGERATION LOCATION SCHEDULE			
	A	CONNECTIONS	
		INLET	SUCTION
2RMCP30	14	3/8 OD	5/8 OD
3RMCP30	23	3/8 OD	5/8 OD
4RMCP30	37	3/8 OD	5/8 OD
5RMCP30	26	3/8 OD	5/8 OD

ELECTRICAL SPECIFICATIONS BY DOOR MANUFACTURER									
MODEL NUMBER	FANS AMPS	T-12 LIGHT AMPS ONE END*	T-12 LIGHT AMPS BOTH ENDS	T-8 LIGHT AMPS	STD. DOOR	MULLION	FRAME	FRAMELESS DOOR	TOTAL FRAME MULLION STD. DOOR
ANTHONY DOORS									
2RMCP30	2.4	1.65	2.4	1.45	0.72	0.43	0.95	0	2.10
3RMCP30	3.2	2.4	3.3	1.94	1.08	0.86	1.12	0	3.06
4RMCP30	4	3.3	4.05	2.42	1.44	1.29	1.18	0	3.91
5RMCP30	4.8	4.05	4.8	2.91	1.8	1.72	1.41	0	4.93
ARDCO DOORS									
2RMCP30	2.4	1.65	2.4	1.89	0.26	0.54	0.36	0	1.16
3RMCP30	3.2	2.4	3.3	2.34	0.39	0.81	0.44	0	1.64
4RMCP30	4	3.3	4.05	3.06	0.52	1.08	0.53	0	2.13
5RMCP30	4.8	4.05	4.8	3.51	0.65	1.35	0.6	0	2.6
* STANDARD FOR CASE IN A LINE-UP									
VOLTAGE: 115 VOLTS 1 PHASE 60 HZ.									
BTU/HR ENERGY REQUIREMENTS: FOR PRODUCT TEMPERATURE OF 37°F TO 41°F WITH 20°F EVAPORATOR									
# OF DOORS	BTU/HR	BTU/HR RATING BASED ON 800 MA T-12 LIGHTING AND PARALLEL RACK SYSTEM. MULTIPLY BY 1.04 FOR CONVENTIONAL SYSTEM.							
2	2735	CASE DESIGNED TO OPERATE IN AN AMBIENT OF 75°F OR LOWER AND RELATIVE HUMIDITY OF 55% OR LOWER							
3	3705								
4	4650								
5	5625								

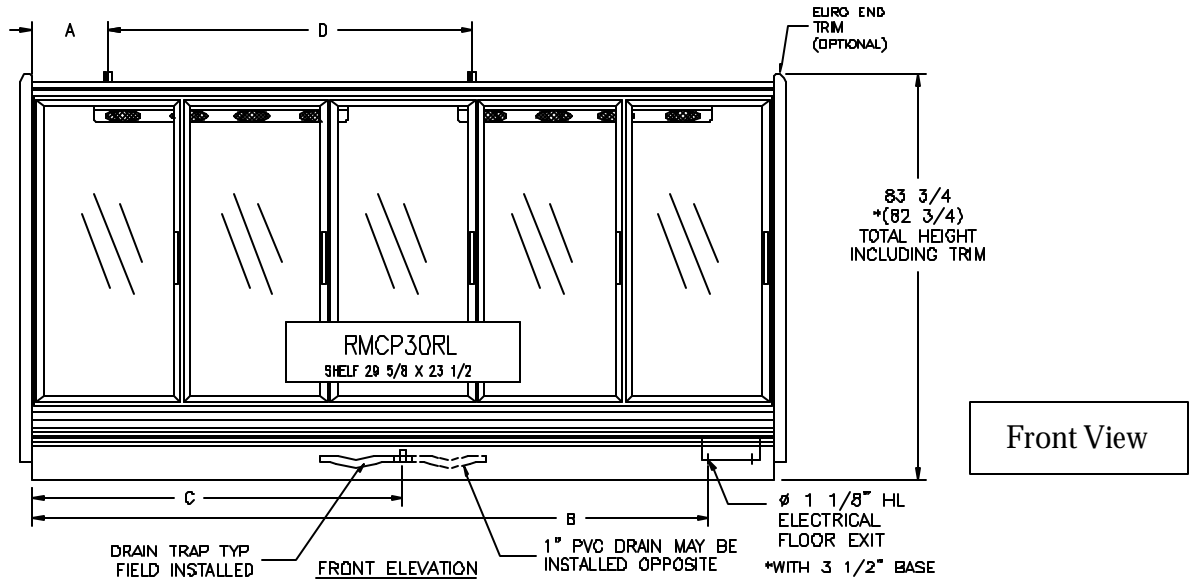
Zero Zone Inc. • 110 N. Oakridge Dr.
North Prairie, WI 53153-9792
1-800-247-4496 • FAX: 1-262-392-6450
www.zero-zone.com

All specifications are subject to change without notice.

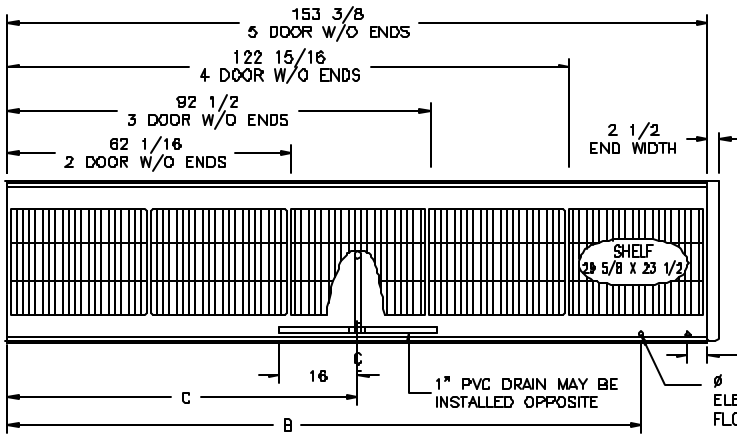


Figure 14

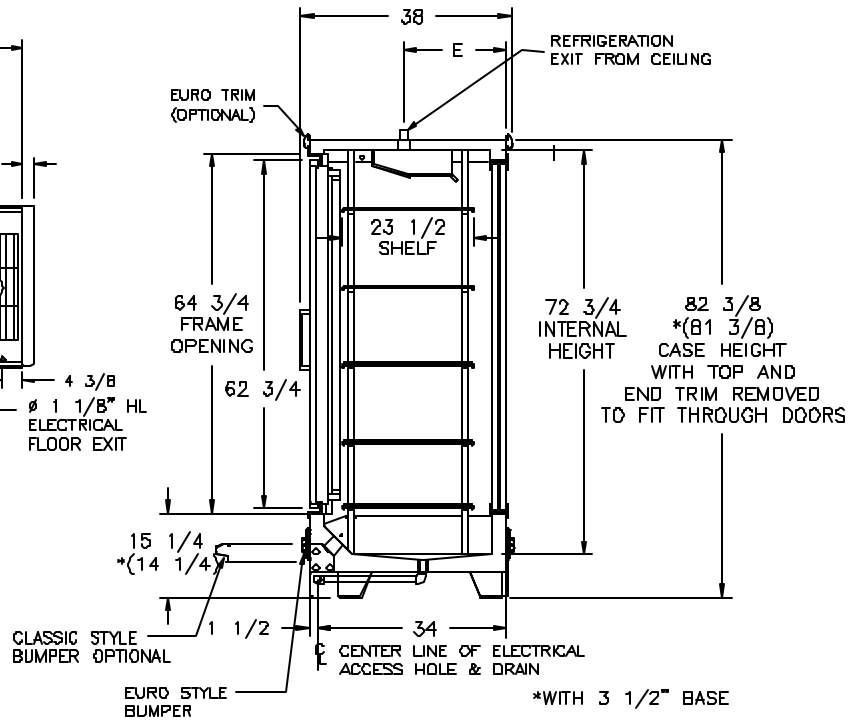
PRELIMINARY RMCP30RL SPECIFICATION SHEET



Front View



Top View
Shown in Section
5RMCP30RL



Side View

* NOTE: CASE DIMENSIONS SHOWN REFLECT STANDARD 4-1/2" HIGH BASES
DIMENSIONS SHOWN IN (PARENTHESIS) REFLECT 3-1/2" BASES.

Zero Zone Inc. • 110 N. Oakridge Dr.
North Prairie, WI 53153-9792
1-800-247-4496 • FAX: 1-262-392-6450
www.zero-zone.com

All specifications are subject to change without notice.



PRELIMINARY

RMCP30RL SPECIFICATION SHEET

ELECTRICAL CONNECTION (B) & DRAIN (C) LOCATION SCHEDULE		
MODEL NUMBER	B	C
2RMCP30RL	48 5/8	31
3RMCP30RL	79 1/16	46 1/4
4RMCP30RL	109 1/2	61 1/2
5RMCP30RL	139 15/16	76 11/16

RMCP30RL CAPACITY SPECIFICATIONS			
CASE SIZE	SHELVING 29-5/8X 23-1/2"	CUBIC FEET CAPACITIES	WEIGHT*
	GROSS SQ. FT.	GROSS CUBIC FT.	POUNDS
2	48.3	59.6	575
3	72.5	88.8	873
4	96.6	118.1	1128
5	120.8	147.3	1440

WEIGHT BASED ON UNCRATED CASES WITHOUT ENDS, AND FULLY SHELVED.
SINGLE END WEIGHT: 54#

MODEL NUMBER	A	D	E	CONNECTIONS	
				INLET	SUCTION
2RMCP30RL	13 11/16	-	18 5/8	3/8 OD	5/8 OD
3RMCP30RL	21 7/8	-	18 1/2	3/8 OD	5/8 OD
4RMCP30RL	37 1/16	-	17 3/8	3/8 OD	5/8 OD
5RMCP30RL	25 11/16	67 3/8	18 5/8	3/8 OD	5/8 OD

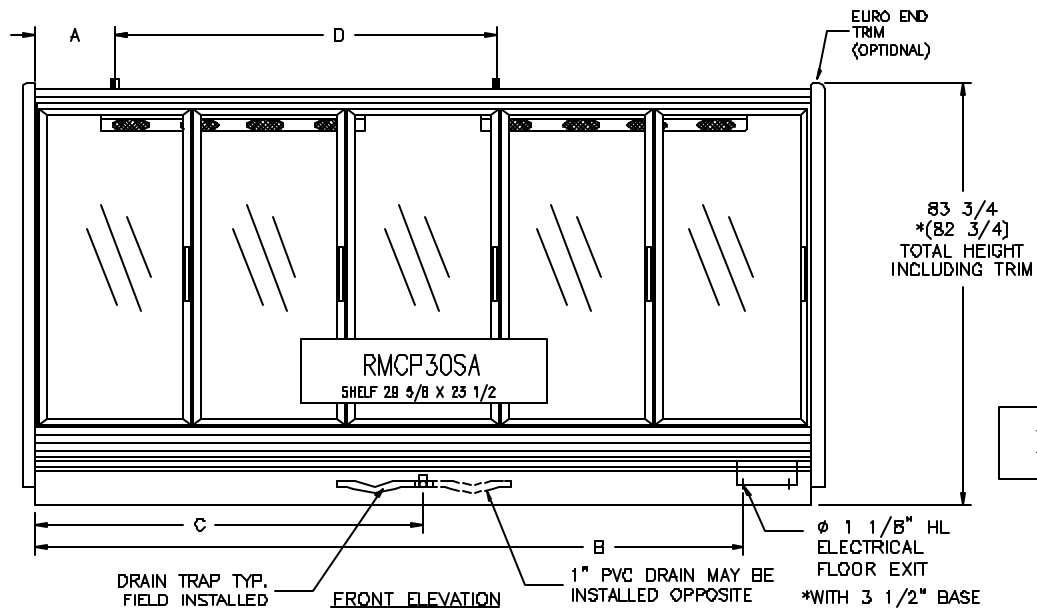
ELECTRICAL SPECIFICATIONS BY DOOR MANUFACTURER									
MODEL NUMBER	FANS AMPS	T-12 LIGHT AMPS ONE END*	T-12 LIGHT AMPS BOTH ENDS	T-8 LIGHT AMPS	STD. DOOR	MULLION	FRAME	FRAMELESS DOOR	TOTAL FRAME MULLION STD. DOOR
ANTHONY DOORS									
2RMCP30RL	2.4	1.65	2.4	1.45	0.72	0.43	0.95	0	2.10
3RMCP30RL	3.2	2.4	3.3	1.94	1.08	0.86	1.12	0	3.06
4RMCP30RL	4	3.3	4.05	2.42	1.44	1.29	1.18	0	3.91
5RMCP30RL	4.8	4.05	4.8	2.91	1.8	1.72	1.41	0	4.93
ARDCO DOORS									
2RMCP30RL	2.4	1.65	2.4	1.89	0.26	0.54	0.36	0	1.16
3RMCP30RL	3.2	2.4	3.3	2.34	0.39	0.81	0.44	0	1.64
4RMCP30RL	4	3.3	4.05	3.06	0.52	1.08	0.53	0	2.13
5RMCP30RL	4.8	4.05	4.8	3.51	0.65	1.35	0.6	0	2.6
* STANDARD FOR CASE IN A LINE-UP VOLTAGE: 115 VOLTS 1 PHASE 60 HZ.									
BTU/HR ENERGY REQUIREMENTS: FOR PRODUCT TEMPERATURE OF 37°F TO 41°F WITH 20°F EVAPORATOR									
# OF DOORS	BTU/HR	BTU/HR RATING BASED ON 800 MA T-12 LIGHTING AND PARALLEL RACK SYSTEM. MULTIPLY BY 1.04 FOR CONVENTIONAL SYSTEM.							
2	2735	CASE DESIGNED TO OPERATE IN AN AMBIENT OF 75°F OR LOWER AND RELATIVE HUMIDITY OF 55% OR LOWER. RATINGS ARE FOR A CASE ATTACHED TO A WALK IN COOLER. FOR OTHER APPLICATIONS PLEASE CONSULT THE FACTORY							
3	3705								
4	4650								
5	5625								

Zero Zone Inc. • 110 N. Oakridge Dr.
North Prairie, WI 53153-9792
1-800-247-4496 • FAX: 1-262-392-6450
www.zero-zone.com

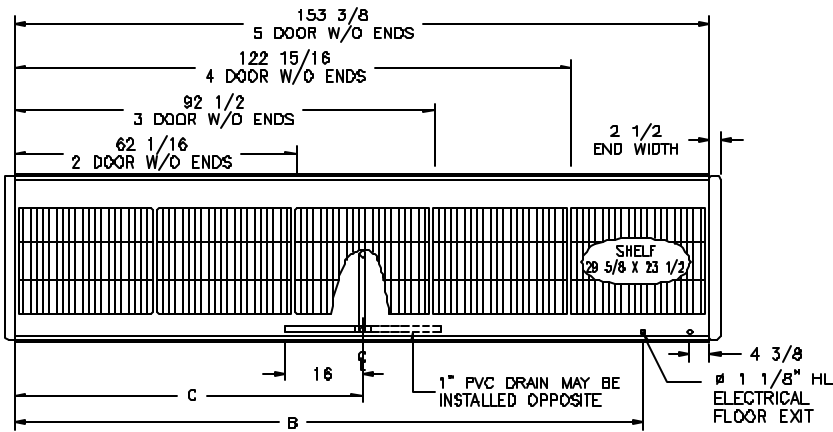
All specifications are subject to change without notice.



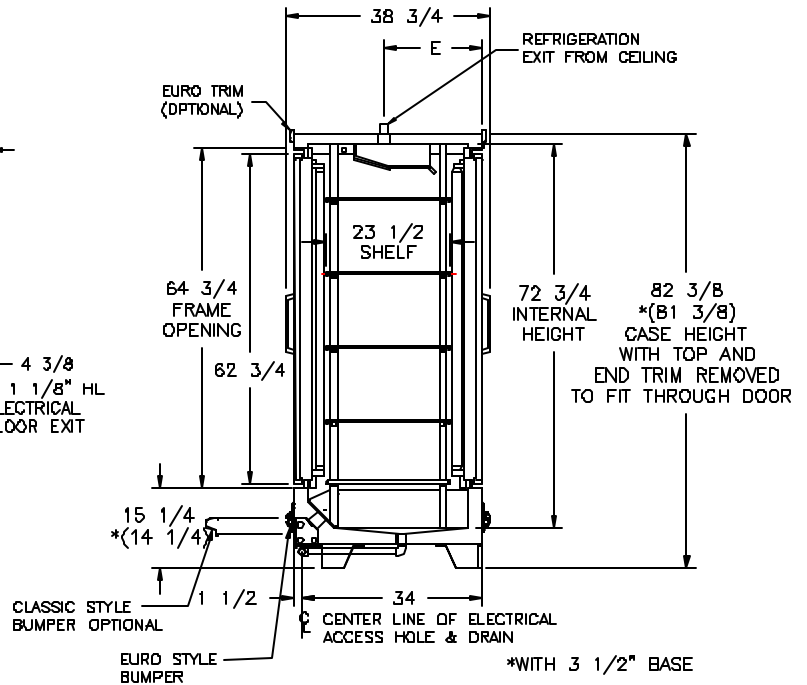
RMCP30SA SPECIFICATION SHEET



Front View



Top View
Shown in Section
5RMCP30SA



Side View

* NOTE: CASE DIMENSIONS SHOWN REFLECT STANDARD 4-1/2" HIGH BASES
DIMENSIONS SHOWN IN (PARENTHESIS) REFLECT 3-1/2" BASES.

Zero Zone Inc. • 110 N. Oakridge Dr.
North Prairie, WI 53153-9792
1-800-247-4496 • FAX: 1-262-392-6450
www.zero-zone.com

All specifications are subject to change without notice.



PRELIMINARY

RMCP30SA SPECIFICATION SHEET

ELECTRICAL CONNECTION (B) & DRAIN (C) LOCATION SCHEDULE		
MODEL NUMBER	B	C
2RMCP30SA	48 5/8	31
3RMCP30SA	79 1/16	46 1/4
4RMCP30SA	109 1/2	61 1/2
5RMCP30RL	139 15/16	76 11/16

RMCP30SA CAPACITY SPECIFICATIONS			
CASE SIZE	SHELVING 29-5/8X 23-1/2"	CUBIC FEET CAPACITIES	WEIGHT*
	GROSS SQ. FT.	GROSS CUBIC FT.	POUNDS
2	48.3	59.6	625
3	72.5	88.8	923
4	96.6	118.1	1,178
5	120.8	147.3	1,490

WEIGHT BASED ON UNCRATED CASES WITHOUT ENDS, AND FULLY SHELVED.
SINGLE END WEIGHT: 54#

MODEL NUMBER	A	D	E	CONNECTIONS	
				INLET	SUCTION
2RMCP30SA	6 11/16	-	18 1/2	3/8 OD	5/8 OD
3RMCP30SA	21 7/8	-	17 3/8	3/8 OD	5/8 OD
4RMCP30SA	14 11/16	45 3/16	18 5/8	3/8 OD	5/8 OD
5RMCP30SA	17 5/16	70	18 1/2	3/8 OD	5/8 OD

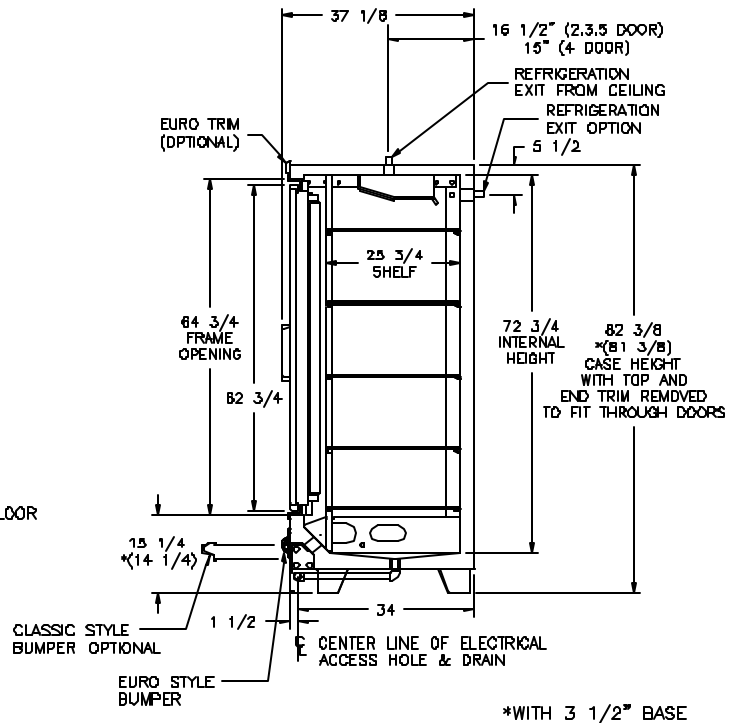
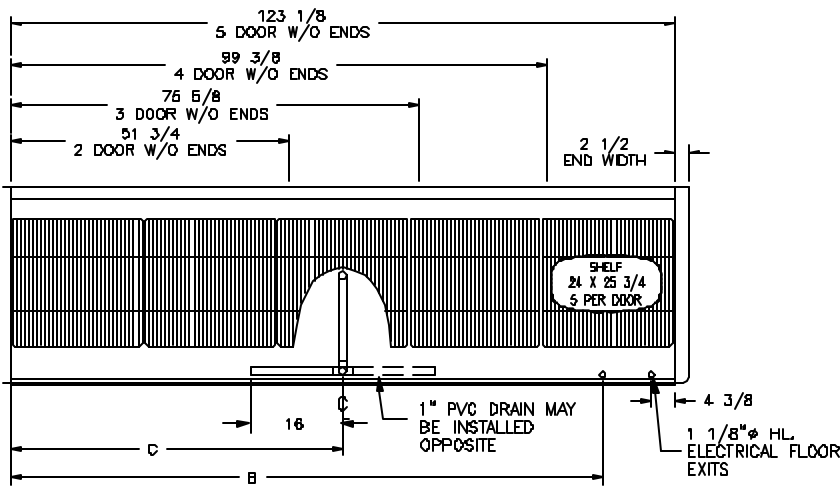
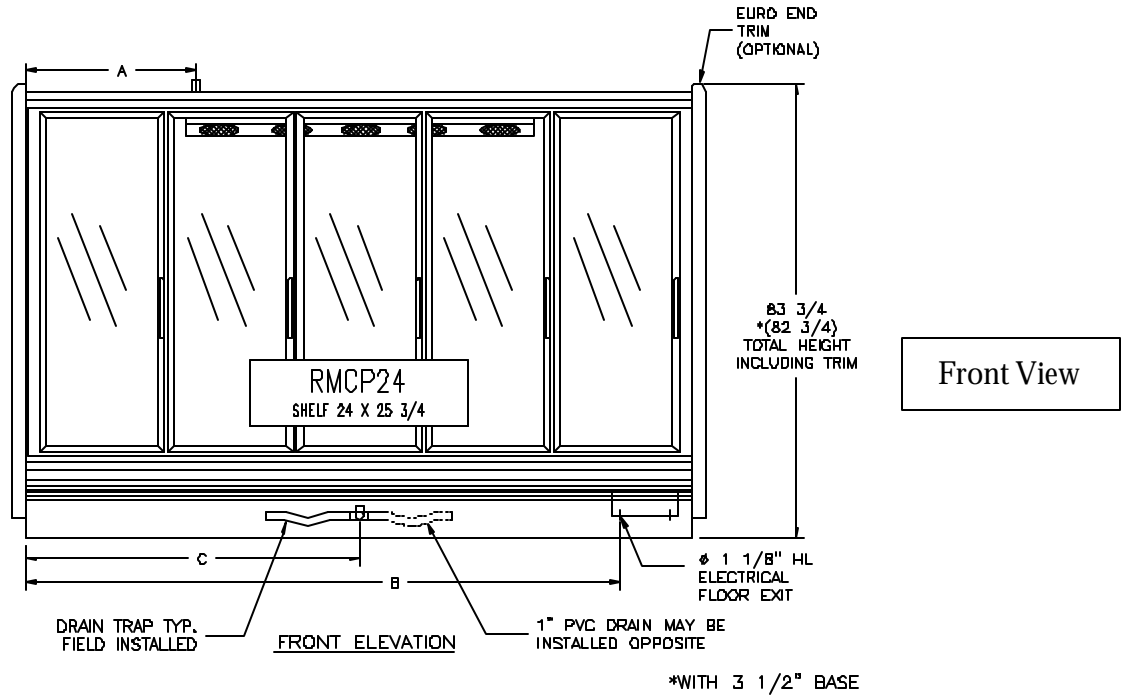
ELECTRICAL SPECIFICATIONS BY DOOR MANUFACTURER									
MODEL NUMBER	FANS AMPS	T-12 LIGHT AMPS ONE END*	T-12 LIGHT AMPS BOTH ENDS	T-8 LIGHT AMPS	STD. DOOR	MULLION	FRAME	FRAMELESS DOOR	TOTAL FRAME MULLION STD. DOOR
ANTHONY DOORS									
2RMCP30SA	2.4	3.3	4.8	2.9	1.44	0.86	1.9	0	4.20
3RMCP30SA	4	4.8	6.6	3.88	2.16	1.72	2.24	0	6.12
4RMCP30SA	5.6	6.6	8.1	4.84	2.88	2.58	2.36	0	7.82
5RMCP30SA	6.4	8.1	9.6	5.82	3.6	3.44	2.82	0	9.86
ARDCO DOORS									
2RMCP30SA	2.4	3.3	4.8	3.78	0.52	1.08	0.72	0	2.32
3RMCP30SA	4	4.8	6.6	4.68	0.78	1.62	0.88	0	3.28
4RMCP30SA	5.6	6.6	8.1	6.12	1.04	2.16	1.06	0	4.26
5RMCP30SA	6.4	8.1	9.6	7.02	1.3	2.7	1.2	0	5.2
* STANDARD FOR CASE IN A LINE-UP									
VOLTAGE: 115 VOLTS 1 PHASE 60 HZ.									
BTU/HR ENERGY REQUIREMENTS: FOR PRODUCT TEMPERATURE OF 37°F TO 41°F WITH 20°F EVAPORATOR									
# OF DOORS	BTU/HR	BTU/HR RATING BASED ON 800 MA T-12 LIGHTING AND PARALLEL RACK SYSTEM. MULTIPLY BY 1.04 FOR CONVENTIONAL SYSTEM.							
2	4,785	CASE DESIGNED TO OPERATE IN AN AMBIENT OF 75°F OR LOWER AND RELATIVE HUMIDITY OF 55% OR LOWER							
3	6,485								
4	8,140								
5	9,845								

Zero Zone Inc. • 110 N. Oakridge Dr.
North Prairie, WI 53153-9792
1-800-247-4496 • FAX: 1-262-392-6450
www.zero-zone.com

All specifications are subject to change without notice.



RMCP24 SPECIFICATION SHEET



Zero Zone Inc. • 110 N. Oakridge Dr.
 North Prairie, WI 53153-9792
 1-800-247-4496 • FAX: 1-262-392-6450
 www.zero-zone.com

All specifications are subject to change without notice.



RMCP24 SPECIFICATION SHEET

ELECTRICAL CONNECTION (B) & DRAIN (C) LOCATION SCHEDULE		
MODEL NUMBER	B	C
2RMCP24	51 7/8	26
3RMCP24	75 5/8	37 7/8
4RMCP24	99 3/8	49 5/8
5RMCP24	123 1/8	61 5/8

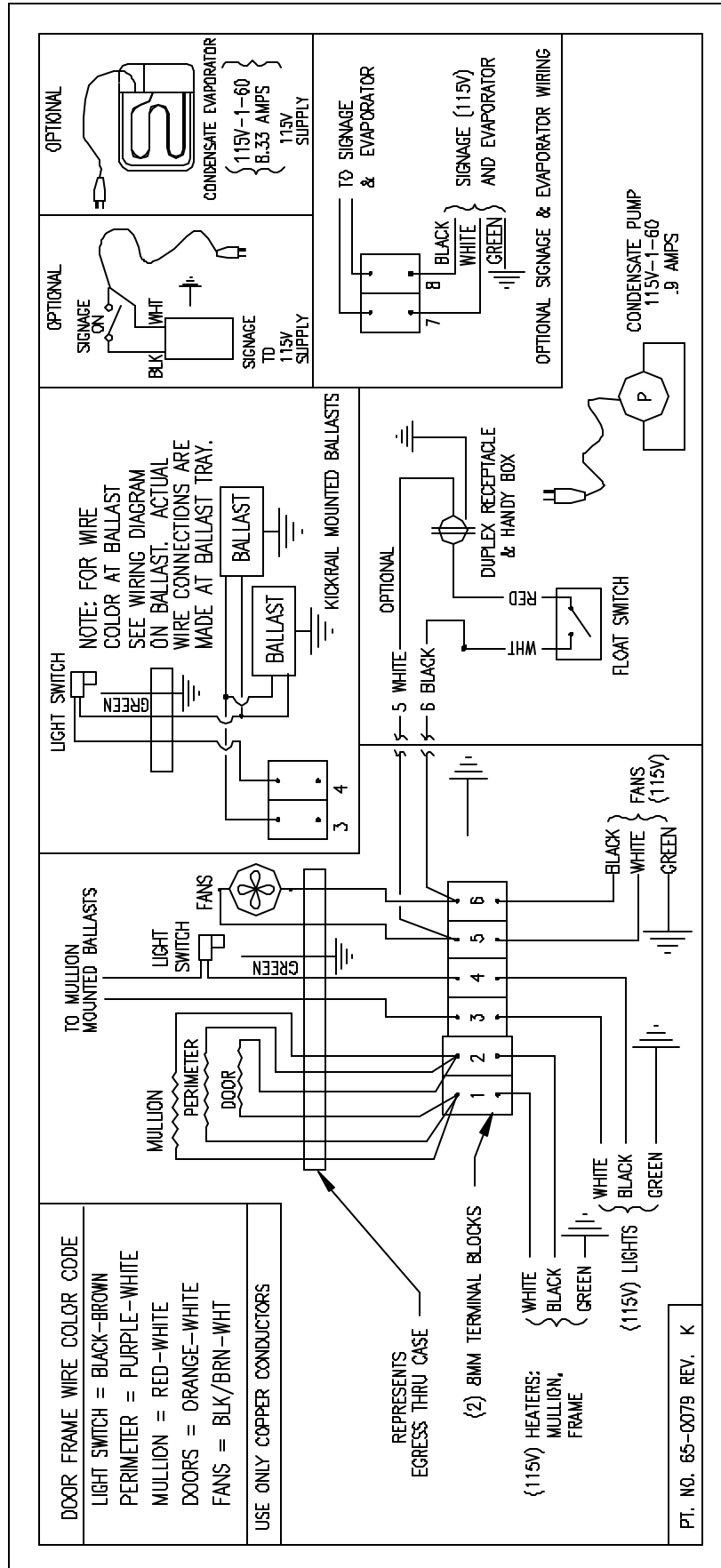
RMCP24 CAPACITY SPECIFICATIONS			
CASE SIZE	SHELVING 24 X 25 3/4"	CUBIC FEET CAPACITIES	WEIGHT*
	GROSS SQ. FT.	GROSS CUBIC FT.	POUNDS
2	43.00	52.9	511
3	64.40	77.3	668
4	85.80	101.5	820
5	107.30	125.8	973
WEIGHT BASED ON UNCRATED CASES WITHOUT ENDS, AND FULLY SHELVED. SINGLE END WEIGHT: 54#			

REFRIGERATION LOCATION SCHEDULE	
MODEL	A
2RMCP24	13 1/8
3RMCP24	20 3/4
4RMCP24	23 7/8
5RMCP24	37 7/8

ELECTRICAL SPECIFICATIONS BY DOOR MANUFACTURER									
MODEL NUMBER	FANS AMPS	T-12 LIGHT AMPS ONE END*	T-12 LIGHT AMPS BOTH ENDS	T-8 LIGHT AMPS	STD. DOOR	MULLION	FRAME	FRAMELESS DOOR	TOTAL FRAME MULLION STD. DOOR
ANTHONY DOORS									
2RMCP24	2.4	1.65	2.4	1.45	0.6	0.4	0.86	0	1.86
3RMCP24	2.4	2.4	3.3	1.94	0.90	0.8	0.93	0	2.63
4RMCP24	3.2	3.3	4.05	2.42	1.2	1.2	1.03	0	3.43
5RMCP24	4	4.05	4.8	2.91	1.8	1.6	1.22	0	4.62
ARDCO DOORS									
2RMCP24	2.4	1.65	2.4	1.89	0.24	0.48	0.31	0	1.03
3RMCP24	2.4	2.4	3.3	2.34	0.36	0.72	0.39	0	1.47
4RMCP24	3.2	3.3	4.05	3.06	0.48	0.96	0.43	0	1.87
5RMCP24	4	4.05	4.8	3.51	0.6	1.2	0.53	0	2.33
* STANDARD FOR CASE IN A LINE-UP									
VOLTAGE: 115 VOLTS 1 PHASE 60 HZ.									
BTU/HR ENERGY REQUIREMENTS: FOR PRODUCT TEMPERATURE OF 37°F TO 41°F WITH 20°F EVAPORATOR									
# OF DOORS	BTU/HR	BTU/HR RATING BASED ON 800 MA T-12 LIGHTING AND PARALLEL RACK SYSTEM. MULTIPLY BY 1.04 FOR CONVENTIONAL SYSTEM. CASE DESIGNED TO OPERATE IN AN AMBIENT OF 75°F OR LOWER AND RELATIVE HUMIDITY OF 55% OR LOWER							
2	2515								
3	3355								
4	4180								
5	4965								

Zero Zone Inc. • 110 N. Oakridge Dr.
North Prairie, WI 53153-9792
1-800-247-4496 • FAX: 1-262-392-6450
www.zero-zone.com

All specifications are subject to change without notice.



OR

Figure



1. **LIMITED WARRANTY.** ZERO ZONE, INC. ("SELLER") HEREBY WARRANTS THAT ANY PRODUCTS MANUFACTURED BY IT AND SOLD UNDER THIS WARRANTY SHALL BE FREE FOR A PERIOD OF ONE YEAR FROM THE DATE OF SHIPMENT, FROM DEFECTS IN MATERIAL AND WORKMANSHIP WHICH, UNDER NORMAL USE AND SERVICE WOULD RENDER SUCH PRODUCTS UNUSABLE OR UNSERVICEABLE. THE OBLIGATION OF SELLER UNDER THIS WARRANTY SHALL BE LIMITED TO THE REPAIR OR REPLACEMENT OF ANY PARTS THAT THE SELLER DETERMINES ARE DEFECTIVE. THIS LIMITED WARRANTY DOES NOT COVER LABOR, FREIGHT, TRANSPORTATION OR OTHER CHARGES INCIDENTAL TO REPLACEMENT OR REPAIR. PARTS RETURNED TO SELLER MUST BE RETURNED FREIGHT PREPAID AND REPLACEMENTS WILL BE RETURNED TO THE BUYER FREIGHT COLLECT.
2. **MOTOR COMPRESSOR EXTENDED WARRANTY.** SELLER HEREBY WARRANTS WITH RESPECT TO ANY MOTOR COMPRESSOR SOLD UNDER THIS WARRANTY, EXCLUSIVE OF ANY AND ALL PARTS OF THE CONDENSING UNIT ASSEMBLY THEREOF, THAT SUCH MOTOR COMPRESSOR SHALL BE FREE FROM DEFECTS IN MATERIAL AND WORKMANSHIP FOR A PERIOD OF FOUR (4) YEARS FROM THE DATE OF THE EXPIRATION OF THE ONE YEAR WARRANTY PROVIDED BY THE MANUFACTURER OF SUCH MOTOR COMPRESSOR, **IF THE BUYER PURCHASES SAID WARRANTY AT THE TIME OF EQUIPMENT PURCHASE.** IN THE EVENT THE MOTOR COMPRESSOR IS NOT FREE FROM DEFECTS IN MATERIAL AND/OR WORKMANSHIP DURING SUCH FOUR YEAR PERIOD, BUYER MUST PURCHASE A REPLACEMENT FOR THE DEFECTIVE MOTOR COMPRESSOR AND OBTAIN WHATEVER SALVAGE CREDIT MAY BE AVAILABLE FROM THE MANUFACTURER THEREOF. UPON RECEIPT BY SELLER OR WRITTEN NOTICE FROM BUYER OF COMPRESSOR, SELLER WILL ISSUE A PURCHASE OR A REFUND, AT SELLER'S OPTION, FOR AN AMOUNT OF THE SALVAGE CREDIT. ALL LABOR AND SHIPPING CHARGES INCURRED IN CONNECTION WITH SUCH REPLACEMENT SHALL BE THE SOLE OBLIGATION OF THE BUYER.
3. **PRODUCT NOT MANUFACTURED BY SELLER.** THE WRITTEN WARRANTY, IF ANY, PROVIDED BY THE MANUFACTURER OF ANY PART OF THE REFRIGERATION UNIT SOLD BY SELLER TO BUYER, BUT NOT MANUFACTURED BY SELLER, IS HEREBY ASSIGNED TO BUYER. HOWEVER, SELLER MAKES NO REPRESENTATION OR WARRANTY REGARDING THE EXISTENCE, VALIDITY OR ENFORCEABILITY OF ANY SUCH WRITTEN WARRANTY.
4. **LIMITATION AND EXCLUSION OF WARRANTIES.** THE WARRANTIES SET FORTH HEREIN ARE EXCLUSIVE AND IN LIEU OF ALL OTHER WARRANTIES AND REMEDIES WHATSOEVER, INCLUDING BUT NOT LIMITED TO, IMPLIED WARRANTIES OF MERCHANTABILITY AND/OR FITNESS FOR A PARTICULAR PURPOSE.
5. **CONSEQUENTIAL DAMAGES.** NOTWITHSTANDING ANYTHING TO THE CONTRARY SET FORTH IN THIS WARRANTY CERTIFICATE, SELLER SHALL NOT BE LIABLE FOR ANY INCIDENTAL OR CONSEQUENTIAL DAMAGES ARISING OUT OF, OR DIRECTLY OR INDIRECTLY CAUSED BY A DEFECTIVE PART SOLD BY SELLER, INCLUDING BUT NOT LIMITED TO, COSTS ARISING FROM THE REPLACEMENT OF THE PART, LOSS OF GAS OR PRODUCT, OR ANY DAMAGE TO PERSON OR PROPERTY, WHETHER AS A RESULT OF SELLER'S NEGLIGENCE, BREACH OF CONTRACT, BREACH OF WARRANTY OR OTHERWISE.