



# Display Coolers

**INSTALLATION  
and OPERATING INSTRUCTIONS for**

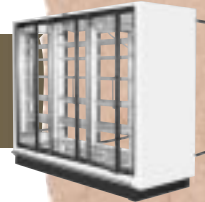
**RMCC30 Series**



**RMCP30 Series**



**Shop Around**



**Rear Load**



**RMCC24 Series**



11

12

13



## TABLE OF CONTENTS

### SUBJECT

<b>GENERAL INFORMATION</b> .....	1
INTRODUCTION .....	1
INSPECTION .....	1
LOCATION .....	1
<b>INSTALLATION</b> .....	1
LEVELING .....	1, 2, 4
JOINING COOLERS .....	4
DRAIN LINE .....	4
CART BUMPER .....	4
<b>REFRIGERATION</b> .....	6
GENERAL .....	6
REFRIGERATION PIPING .....	6
TEMPERATURE CONTROL .....	6-7
LEAK CHECK-EVACUATION-CHARGING .....	7
<b>ELECTRICAL</b> .....	7
<b>DEFROSTING</b> .....	7
<b>USER INFORMATION</b> .....	7
CLEANING .....	7
SHELF LOCATION .....	7-8
LANE DIVIDERS .....	8
SHELF GLIDES .....	8
PRE CUT SALAD RACK .....	8
FLORAL SHELVES .....	8
LOADING THE COOLER .....	9
LIGHT SWITCH .....	9
<b>SERVICE</b> .....	9
CART BUMPER .....	9
EVAPORATOR .....	9
EXPANSION VALVE .....	9
EVAPORATOR FANS .....	9-10
LIGHTS .....	10
BALLASTS .....	10
ALTERNATE LIGHTING - T8 .....	10
CONDENSATE EVAPORATION SYSTEM .....	10

•  
•  
•  
•  
•  
•  
•

)

)



**TABLES**

TABLE 1 RMCC30 LINE SIZE R22 ..... 11-14  
 TABLE 2 RMCP30/RMCP30RL LINE SIZE R22 ..... 11  
 TABLE 3 RMCP30SA LINE SIZE R22 ..... 12  
 TABLE 4 RMCC24 LINE SIZE R22 ..... 13  
 TABLE 5 RMCC24 LINE SIZE R22 ..... 14

**FIGURES**

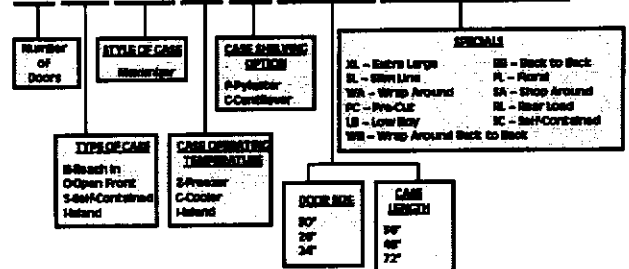
FIGURE 1 LEVELING CASES PRIOR TO JOINING ..... 2-21  
 FIGURE 2 ..... 2  
 FIGURE 2A & 2B CAULKING CASES TO BE JOINED ..... 3  
 FIGURE 3 JOINING RMCP30 REACH-IN COOLERS ..... 2  
 FIGURE 4 INSTALLING THE CART BUMPER ..... 5  
 FIGURE 5 JOINING 30" DOOR REAR LOAD OR SHOP AROUND COOLERS ..... 5  
 FIGURE 6 JOINING 24" DOOR REACH-IN COOLERS ..... 5  
 FIGURE 7 INSTALLING TEE STRIPS ..... 5  
 FIGURE 8 TEMPERATURE CONTROL SETTINGS ..... 6  
 FIGURE 9 TYPICAL TEMPERATURE CONTROLS ..... 6  
 FIGURE 10 LANE DIVIDERS ..... 8  
 FIGURE 11 SALAD RACKS ..... 8  
 FIGURE 12 SOCKET DETAIL ..... 10  
 FIGURE 13 RMCC30 SPECIFICATION SHEET ..... 15-16  
 FIGURE 14 RMCP30 SPECIFICATION SHEET ..... 17-18  
 FIGURE 15 RMCP30RL SPECIFICATION SHEET ..... 19-20  
 FIGURE 16 RMCP30SA SPECIFICATION SHEET ..... 21-22  
 FIGURE 17 RMCC24 SPECIFICATION SHEET ..... 23-24  
 FIGURE 18 RMCC30/RMCP30/RMCC24 WIRING DIAGRAM ..... 25  
 FIGURE 19 RMCP30RL WIRING DIAGRAM ..... 26  
 FIGURE 20 RMCP30SA WIRING DIAGRAM ..... 27

**WARRANTY** ..... 28



This chart will enable you to understand the Zero Zone model number system

**2RMZC30FLSA**



11  
12  
13

14

15



## GENERAL INFORMATION

### Introduction

The information contained in this manual pertains to the following display coolers: RMCC30, RMCP30, RMCP30RL, RMCP30SA and RMCC24. These are used for merchandising refrigerated packaged food. The number 30 in the model number designates a case with 30" wide doors. The number 24 in the model number indicates 24" wide doors.

These display coolers are designed to operate in an air-conditioned store where the temperature is maintained at 75°F or lower and the relative humidity is 55% or lower.

### RMCP30RL (Rear Load)

This case design allows product to be loaded through solid sliding doors at the rear of the case. The case is designed to have the back of the case built into the wall of a cooler. The rear doors do not have lamps but are heated to prevent condensation.

### RMCP30SA (Shop Around)

This case design allows product to be shopped from either side. The evaporator fans face the front of the case. The main wiring compartment is located behind the kick plate in the front of the case.

### Inspection

These display coolers were carefully inspected and properly packed to ensure delivery in the best possible condition. The equipment should be checked for damage immediately upon delivery.

**ALL CLAIMS FOR DAMAGES MUST BE FILED WITH THE TRANSPORTATION COMPANY - NOT WITH ZERO ZONE.** The carrier will supply necessary report and claim forms.

### Location

Do not locate this equipment where it will be exposed to the direct rays of the sun or near a source of radiant heat or airflow.

Be certain that the floor under the installation is of sufficient strength to prevent sagging. Out of level conditions will result in reduced performance.

Wall cases and back to back cases should be positioned to allow a 1 - 4 inch space behind the back of a unit. This space will allow air to circulate behind the unit.

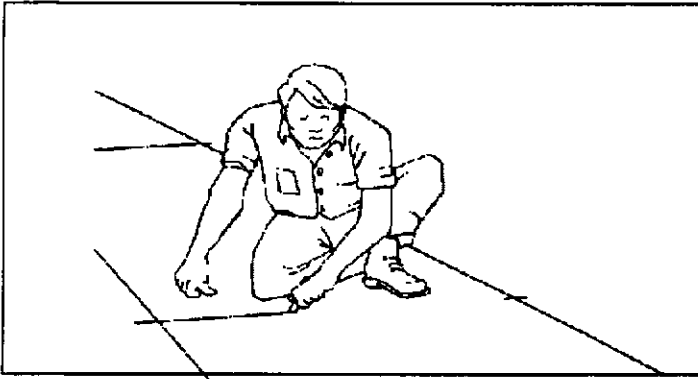
## INSTALLATION

### Leveling (See Figure 1)

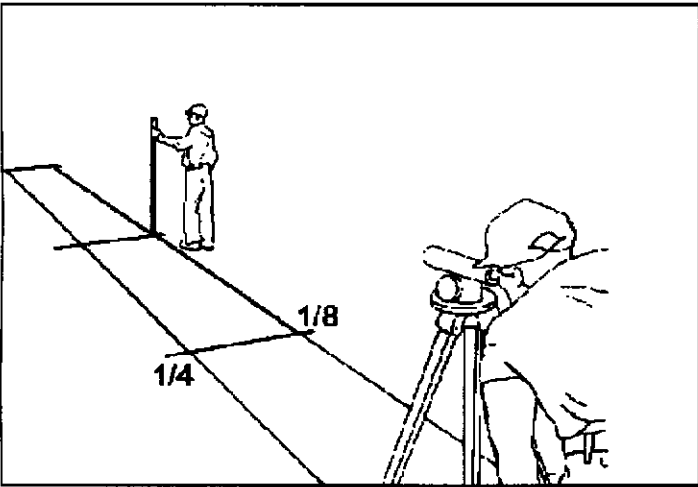
Refrigeration equipment must be installed level to allow efficient operation of the refrigeration coils and complete drainage of defrost water. Since a level area is seldom available, the following steps are recommended to insure a level installation.

1. Measure off and mark on floor the exact dimensions of the case line-up. (Check blueprints).
2. Snap a chalk line at the locations for the front and back positions of the base rails.
3. Mark locations of all joints (front and back).
4. Using a transit or laser level, find the highest point along both base rail position lines. Using the high point as a reference, mark the difference directly on the floor at each joint (front and back).
5. If a transit is not available, a water level can be used to mark reference elevation points. Water levels can be purchased from a contractor supply house for a minimal cost.
6. A string level can also be used to mark elevation points. The string level should only be used on short line-ups to avoid string sag.

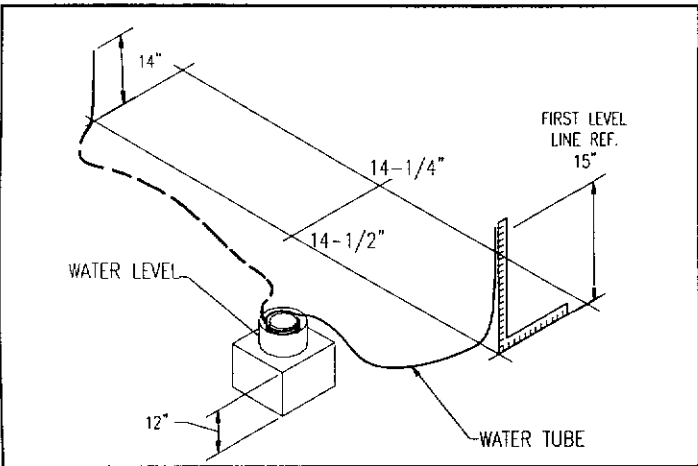
Figure 1: Leveling cases prior to joining



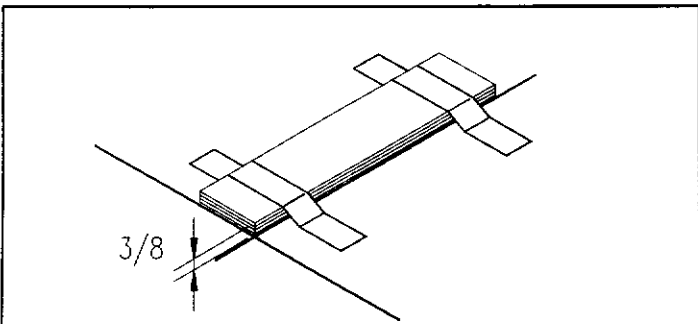
Measure and mark exact case outline



Mark floor level differences



Water level elevation points



Shim joints to equal highest points

**JOINING BOLTS REQUIRED FOR MZP & MCP CASE**

ITEM	QTY.	DESCRIPTION	Z.Z. PART NO.
①	(1)	3/8 - 16 X 3 HEX HD CAP SCR	64-0025
②	(4)	3/8 - 16 X 1 1/2 HEX HD CAP SCR	64-0080
③	(10)	3/8 FLAT WASHER	64-0034
④	(5)	3/8 - 16 HEX NUT	64-0064

Figure 3: Joining 30" Door RMCC30 and RMCP30 Reach-In Coolers



**SPECIAL INSTALLER JOINING APPLICATION NOTE!**

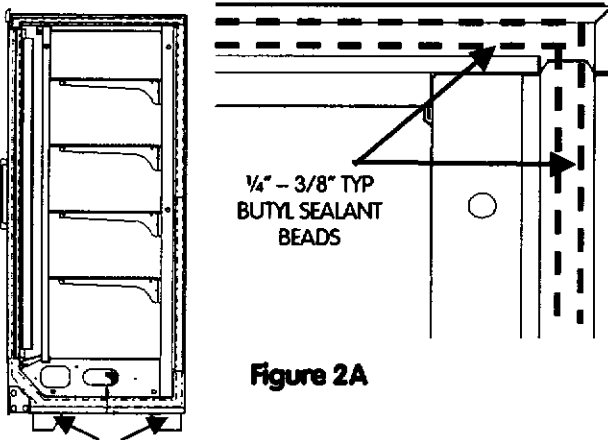
**DO NOT APPLY EXCESS AMOUNTS OF BUTYL SEALANT TO CAUSE IT TO SQUEEZE ON TO END FRAME METAL AREAS.** Caulk-sealant used to join cases and complete the sealing requirements for NSF compliance, should not come in contact with butyl sealant. Apply to clean, dry surfaces free of contaminants that adversely affect adhesion and could change color of sealant joint areas over period of time.

## JOINING CASES

**THESE PROCEDURES ARE CRITICAL**

**FAILURE TO FOLLOW THESE GUIDELINES WILL RESULT IN A POORLY FUNCTIONING CASE!**

### COOLER SHOWN



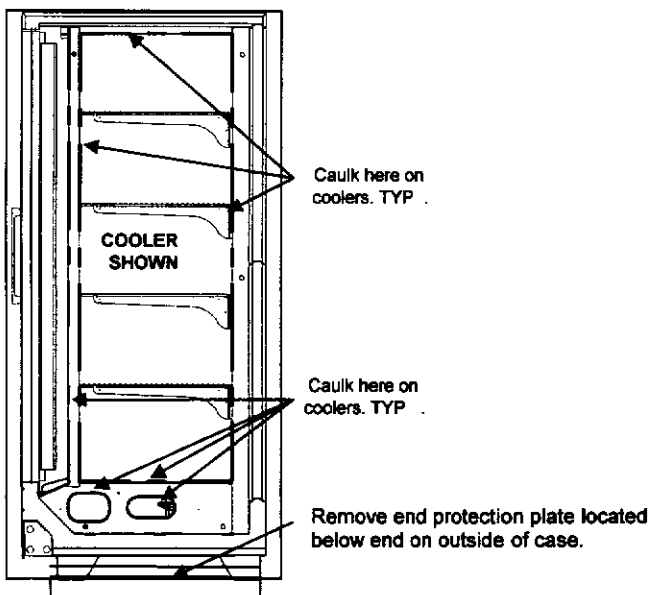
**Figure 2A**

Remove (4) foam shipping blocks if applied to inside of base ends before joining cases.

1. Apply two 1/4" to 3/8" wide beads (Figure 1) of BUTYL SEALANT, 1/2" in from the inside and outside edges of foamed insulated Ceiling, Rear Wall, Base and Door Frame that will be joined together. Apply to only one (1) case joint when joining together as not to apply excessive amounts of butyl sealant that would squeeze out of joint.
2. After cases are joined, caulk the top and back exterior seams (IF POSSIBLE) at this time as well.
3. When joining ends of all ZERO ZONE freezers and coolers, caulk sealant should be applied in the same like manner for joints

## REQUIRED SEALING FOR NSF APPROVABLE INSTALLATION ONLY

**SURFACE TEMPERATURE SHOULD BE ABOVE 40° F AND FREE OF FROST.**



**Figure 2B**

1. Apply non-porous/non-absorbent good quality silicone caulk-sealant or (Manus Bond 75-AM) after end panel is joined to case or when second case is joined with first case.
2. Apply solid caulk-sealant bead to areas shown in Figure 2 to meet sealant requirements for NSF approved installations.
3. Apply small beads of sealant smoothly, but do not thin or feather excessively, because it may affect adhesion.

**NOTE:** Caulk sealant lines are shown dashed. Field caulk is applied continuously. Figure 2 does not show areas excluded for coolers



7. Place the required number of shims (supplied) at each joint (front and back) to equal the highest point. Tape all shims in place.
8. Place additional support shims every four feet for four and five door case base rails (front and back).
9. Use a carpenter's level to check installation as you go. The case should be level from front to back and side to side. Install the case at the highest point first, if part of a line-up.

## Joining Coolers

These reach-in coolers have been engineered for continuous display. This means that any number of cases can be joined together to create a display of any desired length. Reach-in coolers are built on permanent steel skids to promote easy installation. The cases can be moved on pipe rollers or with a Johnson Bar. The ends of the case are protected with a removable steel plate.

To install Reach-Ins, perform the following steps:

1. Set the first Reach-In into the desired position and level it. Run a 3/8-inch diameter bead of Butyl caulk 1/2 inch in from both the inner and outer surfaces of the case end. (See Figure 2A)
2. Push the second Reach-In against the end of the first. Level the second Reach-In. See Figure 3 for 30" door cases; Figure 5 for 30" door Reach-In Rear Load and Shop Around cases; and Figure 6 for 24" Door Reach-In Coolers. Install tee strips between the doorframes at case joints (Figure 7). Use the special screws and nuts provided.
3. Start the joining bolts, but do not tighten them. Begin tightening the bolts at the top rear, working down the back of the case and up the front making sure that the front seams are flush.
4. For NSF case installation, the interior case seams need to be sealed using NSF approved caulk (see Figure 2B)

## Drain Line

Condensate water drains from the evaporator through a plastic hose mounted at the rear of the case. The tubing should be free of kinks and dirt so water drains freely. The case drain is located at the center of the cooler in the floor pan. The 1-inch PVC drain outlet is located at the center front of the cooler behind the kick plate.

The tee, drain trap, and plug are supplied standard with the case. Install a tee to the outlet pipe and a PVC drain trap to the tee. Plug the open end of the tee using the clean-out plug supplied with the drain trap kit. The drain trap should be level to maintain a liquid seal and the drain line must be pitched away from the case a minimum of 1/4 inch per foot.

## Cart Bumper

The cart bumper should be installed at the bottom front of the case. (See Figure 4) The assembly is adjustable to compensate for uneven floors.

Center and hook the bumper assembly on the hanger provided.

In continuous line-ups, place a kick plate joint strip at each joint. On case ends, lineup the end kick plate with the front mounting holes. Fasten the rear of the end kick plate to the case using self-drilling (TEK) screws.

Slide the front kick plate behind the bumper assembly and in front of the end kick plate or kick plate joint strip. Install three screws (two screws on 2-door only) to hold the kick plate and bumper in place. The screws attach the kickplate to a bracket with a speed nut (tinnerman clip).

A bumper joint strip can be installed over the bumper at the joints. This is standard on the Euro Style bumper.

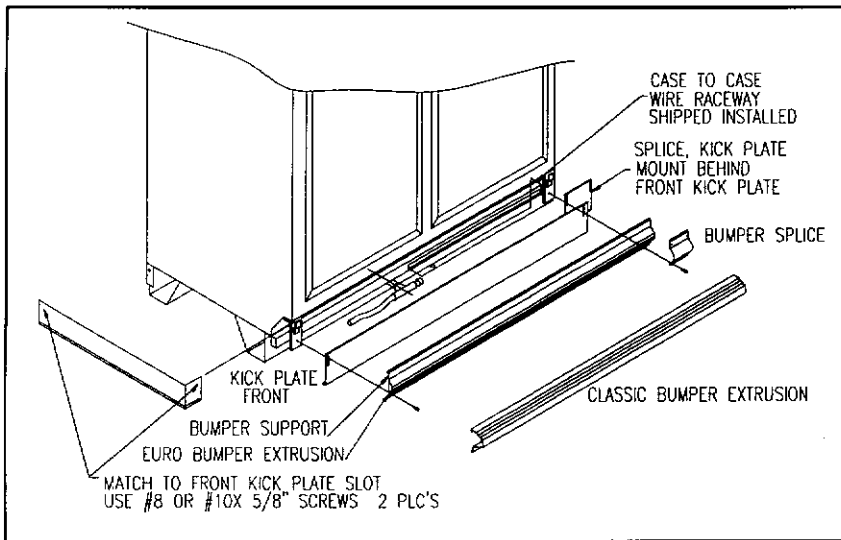


Figure 4: Installing The Cart Bumper

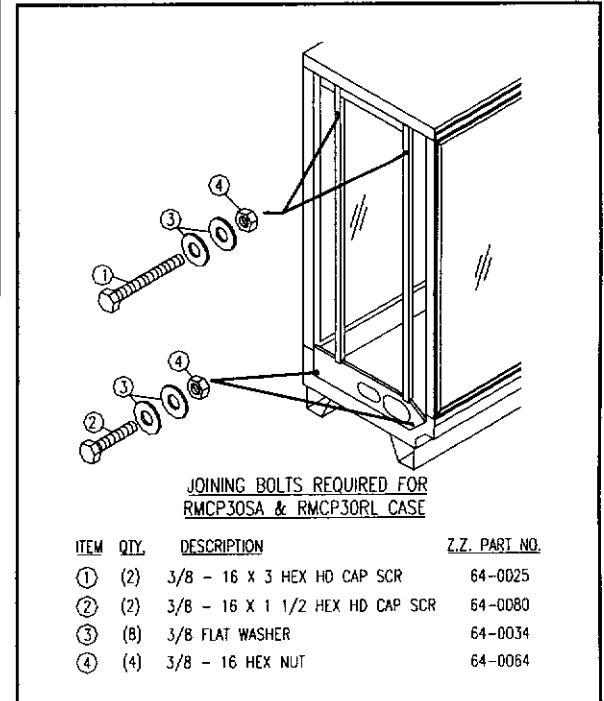


Figure 5: Joining 30" Door Rear Load or Shop Around Reach-In Coolers

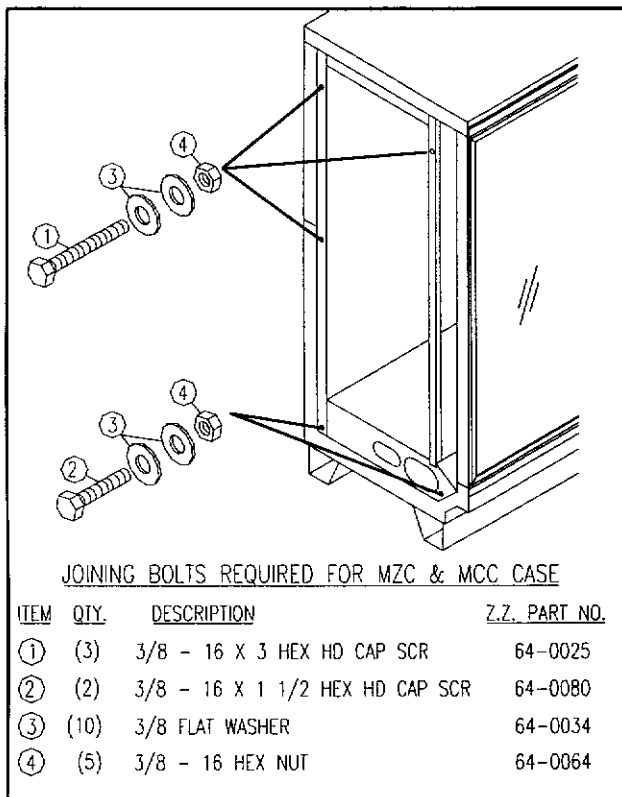


Figure 6: Joining RMCC30 & RMCC24 Coolers

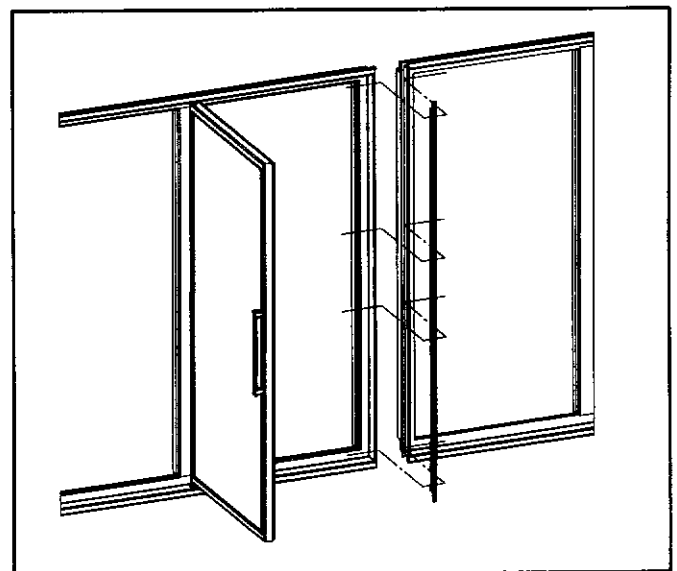


Figure 7: Installing Tee Strips



## REFRIGERATION

### General

Unless otherwise specified, the liquid and suction connections are made on top of the case for RMCP30 models. On RMCC30 and RMCC24 cases the connect is located under the coil cover at the bottom of the case (Figures 13-17.) Alternate locations are out the back of case. After connections are made, the refrigeration access hole in the cooler must be sealed completely with aerosol-dispensed Urethane insulation or equivalent.

### Refrigeration Piping

Correct refrigeration line sizing and installation is essential for proper system operation. The following tables (Tables 1-4) list R-22 line sizes for different combinations of coolers. A P-trap must be installed at the bottom of all vertical suction risers.

The compressor should be installed as close as possible to the coolers to reduce pressure drop

The suction and liquid lines may be taped together to form an external heat exchanger. Insulate the tubing for at least 20 feet from the cooler outlet.

TIME CLOCK DEFROST PRODUCT 41° F TO 37° F		
	Pressure (psig)	RETURN AIR TEMP.
	R-22	
Cut In	64	37° F
Cut Out	40	33° F
OFF CYCLE DEFROST PRODUCT 41° F TO 37° F		
	Pressure (psig)	RETURN AIR TEMP.
	R-22	
Cut In	68	40° F
Cut Out	42	34° F

Figure 8: Temperature Control Settings

A liquid line drier should be installed. Install a moisture indicating sight glass at the outlet end of the drier.

## Temperature Control

A low pressure or temperature control located to sense return air can be used to control cooler temperature. The control should be selected with adequate contact capacity for the switching load. In rack systems, an evaporator pressure-regulating valve may be used to control the evaporating temperature.

The settings (See Figure 8) are approximate due to variations in gauge accuracy, differences in compressor efficiency, and line pressure drop. These should be adjusted as store or stocking conditions change.

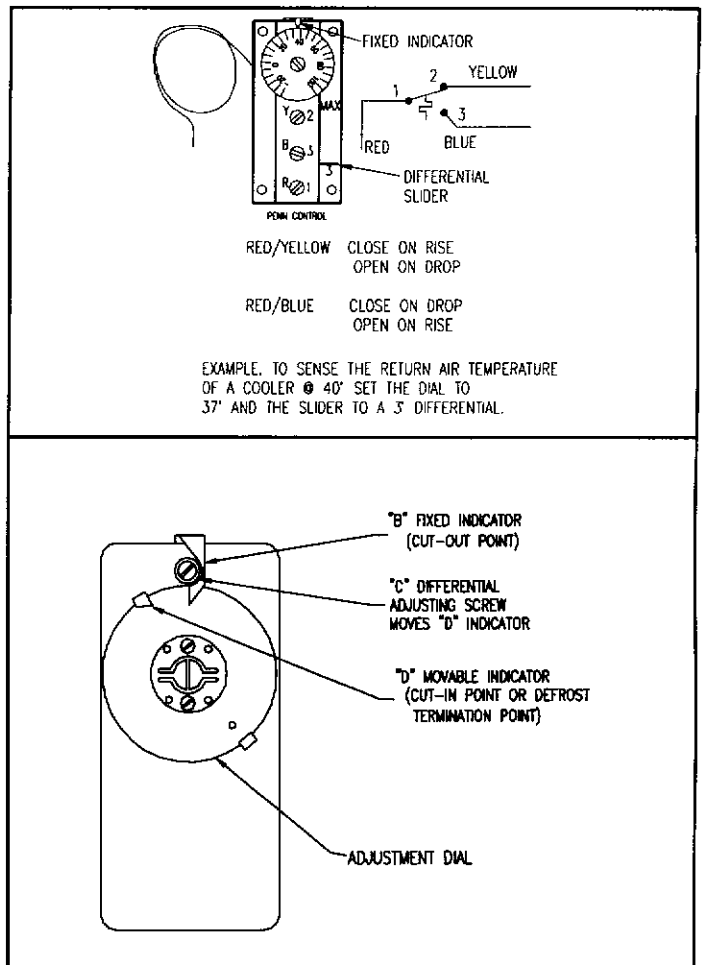


Figure 9: Typical Temperature Controls



## Temperature Control Adjustment

When factory installed, the temperature control is located on top of the cooler for RMCP30 models. On RMCC30 and RMCC24 models the control is located in the electrical box behind the kickplate. The sensing bulb is located under the coil cover in front of the coil. (Figure 9 shows typical temperature controls).

## Leak Check-Evacuation-Charging

After all of the refrigeration piping and system components have been assembled, the entire system must be pressurized and checked for leaks. Use nitrogen and refrigerant vapor to check for leaks. A Halide leak detector or an electronic leak detector is recommended.

If the system is sealed, evacuate with a high vacuum pump. Triple evacuation to a minimum of 500 microns and a nitrogen sweep is recommended. After the system has been thoroughly evacuated of all moisture and non-condensable gas, charge the system with the proper refrigerant, using "hi-side/low-side" charging techniques.

## ELECTRICAL

Figures 18-21 show wiring diagrams for the various coolers. Each case is provided with a wiring diagram located in the electric box that shows the exact wiring of the case.

External wiring should be sized according to the amperage rating stamped on the serial plate. The serial plate is located on the ceiling inside the left-hand door. Typical electrical values are shown in Figures 13-17. All internal wiring has been done at the factory, and has been terminated in the electrical compartment located behind the kick rail at the right end of the case.

The temperature control mounted on top of the case is not wired. A terminal block has been used to simplify field connections.

The fan circuit is energized at all times. The light and anti-condensate circuits may be cycled off during defrost. If a time clock is used, it is energized at all times.

Note: All wiring must comply with the National Electrical Code and all local codes.

## DEFROSTING

Periodic defrosting to keep the coil free of frost is accomplished either automatically by a time clock or with compressor off-cycle defrost. The most reliable defrost system uses a time clock that turns off the refrigeration cycle three times per day for 30 minutes. A time clock can be purchased from Zero Zone or from a local refrigeration supply house.

When only off-cycle defrost is used, the compressor must be sized large enough to allow for periodic off-cycles. When the compressor shuts off, the evaporator fans continue to run. This allows the coil to defrost. The cut-in set point for the compressor should not be lower than 40°F when off-cycle defrost is used.

## USER INFORMATION

### Cleaning

The cooler should be thoroughly cleaned before start-up and routinely thereafter to maintain a clean appearance. Use mild detergent and warm water (never an abrasive cleaner) to wipe out the inside of the cooler. Wash down all glass doors with glass cleaner. The cooler will remain bright and sparkling with just a few minutes of cleaning each week. The case drain should be regularly cleared of debris and price tags.

Note: Do not use high-pressure water or steam to clean the interior.

### Shelf Location

The shelves are adjustable in 1" or 1/2" increments. They may be located in any position for best display.

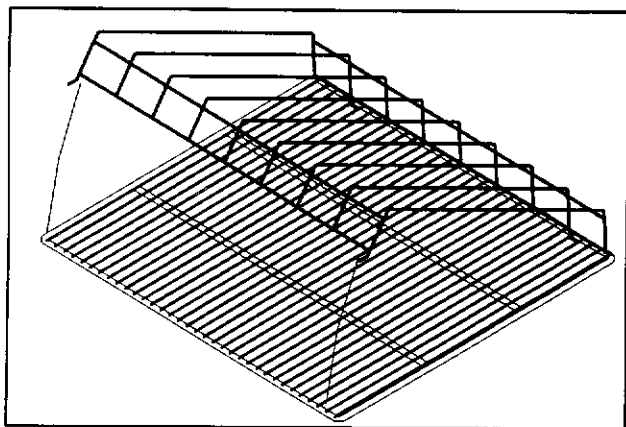


Figure 10: Lane Dividers

advantage. Due to the air discharge arrangement, it is suggested that the uppermost shelf be placed 11 inches down from the ceiling. Place the remaining shelves approximately 10 1/2 inches apart.

**Be sure shelf clips or brackets are completely seated before installing the shelf.**

### Lane Dividers (RMCP30 Only)

Lane dividers with 2-7/8 inch, 3-1/4 inch, 3-3/4 inch, or 4-3/4 inch wide lanes are available for use on the shelves. The rear of the lane divider has the shelf hooks inset from the end. The lane divider is installed by hooking the rear hooks under the large shelf wire (See Figure 10). Flex the lane divider and hook the wire under the large front shelf wire.

### Shelf Glides (RMCP30 Only)

Shelf glides are available for use with lane dividers. This helps the product gravity feed to the front of the case.

### Pre Cut Salad Rack

The rear of the rack has two feet that slip under the shelf wires. The rear of the rack also has a raised wire stop. The stop is used to provide an air gap between the product and rear wall.

The rack is installed as follows:

1. Set the rack on top of the shelf.

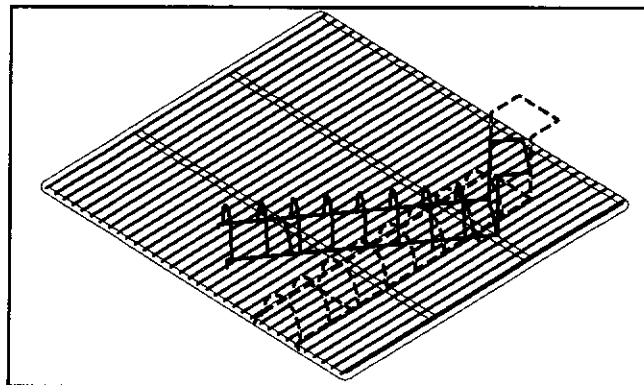


Figure 11: Salad Rack

2. Rotate the rack 45 degrees to the side.
3. Slide both rear feet under the shelf wires.
4. Rotate the salad rack back to the original position while keeping the rear feet under the wires.
5. Gently squeeze the front of the rack and slide the two feet between the shelf wires (See Figure 11).

### Floral Shelves (RMCP30 Only)

Glass cantilever floral shelves are available. The shelves rest on special extra wide shelf brackets.

Cantilever floral bucket shelves are also available. The bucket shelf bracket is adjustable to allow for shelf tilting. Before attempting to adjust the shelf bracket, follow these steps:

1. Remove the shelf.
2. Remove the set screw from the side of the bracket.
3. Rotate the bracket to the new position.
4. Install the set screw.

Cantilever shelf brackets should be firmly seated with a hammer or block into the shelf standards.



## Loading the Cooler

The cooler may be loaded with merchandise after it has been operated for at least 24 hours with correct case temperature and proper control operation. While loading the shelves, leave at least 1 1/2 inch between the top of the merchandise and the shelf above it so the customer can remove the merchandise. Leave a 1 1/2-inch air gap at the rear of the standard RMCP30 cooler. This allows cool air to travel down the back of the product and return to the evaporator at the front of the case. The 1 1/2-inch space allows an air curtain on the top of the product.

## Light Switch

The light switch is located inside the case on the mullion of the last right hand door. **Always turn the lights off when replacing lamps.**

## SERVICE

### Cart Bumper

The cart bumper must be removed to gain access to the drain connection and electrical connection. Disassemble the bumper and black kick plate by removing the 2 or 3 metal screws located in the kick plate. The bumper assembly can be lifted up and removed from the case. The kick plate can be removed, exposing the electrical connection and drain outlet. (Figure 4 shows the bumper assembly)

### Evaporator

The evaporator coil is located at the ceiling of the RMCP30 cases and is factory assembled with an expansion valve. To inspect the coil, the coil cover can be removed as follows: Loosen two screws on the underside of the coil cover until the forward edge drops down exposing the evaporator coil and fan assemblies.

While supporting the cover, unplug the fan electrical connection from the main coil housing.

The evaporator coil, located at the rear bottom of the RMCC30 and RMCC24, is factory assembled with distributor, expansion valve, and heat exchanger. To inspect the S-Coil, remove the center or left of center coil cover. A small inspection port is located at the rear of the case. To inspect the entire 30" coil, remove the remaining coil covers and raise the evaporator cover.

Removing the screws from the coil cover accesses the coil on the 24" door cases. Rotating it at the rear integral hinge can raise the cover.

### Expansion Valve

A thermostatic expansion valve with a "C" charge, adjustable superheat and thermal bulb is mounted to the evaporator coil. Under certain conditions, it may be necessary to adjust the superheat setting for maximum coil effectiveness. Typical superheat settings are between 10°F and 15°F. To adjust the expansion valve, remove the coil cover. Remove the cap from the bottom of the valve. When looking at the valve stem end, turn the valve stem counterclockwise to decrease superheat. Turn the valve stem clockwise to increase super heat. Measure the suction line temperature at the expansion valve-sensing bulb and compare it to the suction temperature corresponding to the saturated pressure. Make sure that line pressure drop is taken into account.

Turn the valve stem only 1/4 turn at a time and allow sufficient time (20 to 30 minutes) for the valve to settle before making any further adjustments. Replace the valve stem cap after the valve superheat has been adjusted. **BE CERTAIN THE VALVE STEM CAP IS WIPED DRY FIRST.**

**! CAUTION !**  
**DISCONNECT POWER TO THE CASE BEFORE**  
**SERVICING ELECTRICAL COMPONENTS**

### Evaporator Fans

Air is circulated throughout the cooler with shaft down, 115-volt medium temperature fan motors. These motors must be operating at all times. The

RMCC30, RMCP30, RMCP30RL, RMCP30SA, RMCC24  
03035



fans are mounted on the evaporator coil cover. To service the fans, they are accessed by removal of the coil cover as described under SERVICE/EVAPORATOR.

## Lights

High output 800 milliamp lamps are standard on the RMCP30 models. To ensure maximum component life, always replace with 800 milliamp lamps. Use retainer clips and lamp shields.

To change a lamp, turn off the light switch and remove the retainer clip located between the top socket and end cap. Carefully push the lamp up into the spring-loaded lamp socket to allow the lamp to be removed from the bottom socket. (See Figure 12.) Remove the end caps and shield. **All lamps must use end caps and shields.**

## Ballast

Zero Zone cooler ballasts are located either behind the kick plate or in the door mullions.

## Alternate Lighting -T8

T-8 lighting is standard on the RMCC30 and RMCC24 cases. Many door manufacturers provide premium lighting systems. These systems use a lens to direct light output evenly across the shelves. The lens must be removed to access the lamp. Ardc's lamp may be removed by turning it 90 degrees and sliding the lamp pins out of the lamp socket slot. The lens must be installed over the lamp. Anthony's lamp is removed by sliding the end caps off of the lamp. Detailed information is contained in the door instruction booklet.

## Condensate Evaporation System

Zero Zone remote cases can be equipped with an automatic condensate evaporation system. The system uses a pump and drain pan located behind the kick plate and a condensate evaporator pan mounted on the top of the case.

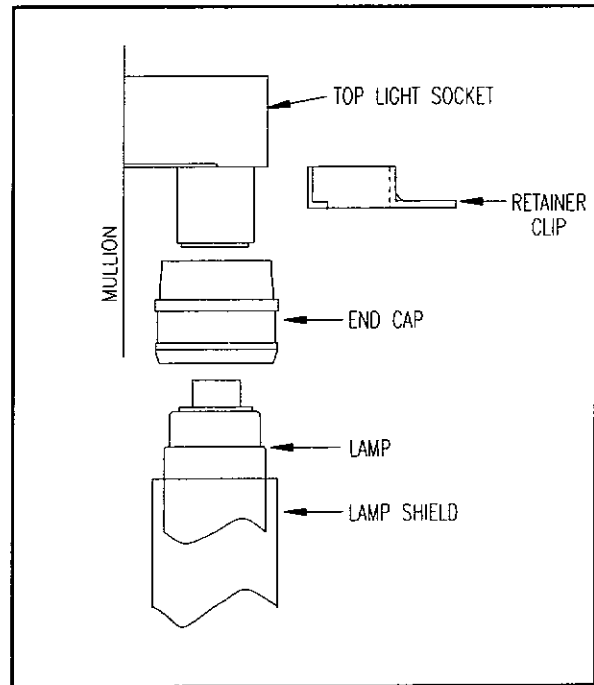


Figure 12: Socket Detail

Condensate water and any liquid spilled in the case drain out into the drain pan. The pump is equipped with a float that turns the pump on when there is a sufficient liquid level. Liquid is pumped through a plastic hose through a check valve and into the condensate-evaporating pan. The evaporating pan is equipped with a heater and a float switch to turn on when the heater is submerged in liquid. When the heater is energized the pan will be extremely hot and should not be touched.

The pump and condensate pan should be cleaned regularly. Any spilled product should be cleaned to prevent odors.





Table 1

REMOTE REACH-IN COOLER W/ 30" X 63" DOORS MODEL RMCC30 WITH STANDARD DOORS REFRIGERANT R-22 @ +25°F EVAPORATOR TEMPERATURE									
NO. OF DOORS	COOLER COMBINATIONS	TOTAL LENGTH W/ENDS	BTU/HR	RECOMMENDED LIQUID LINE SIZES EQUIVALENT LENGTH, FEET			RECOMMENDED SUCTION LINE SIZES EQUIVALENT LENGTH, FEET		
				50	100	150	50	100	150
2	(1) 2-DR	5'-7 1/16"	2,480	3/8	3/8	3/8	1/2	1/2	1/2
3	(1) 3-DR	8'-1 1/2"	3,450	3/8	3/8	3/8	1/2	1/2	1/2
4	(1) 4-DR	10'-7 15/16"	4,360	3/8	3/8	3/8	1/2	1/2	5/8
5	(1) 5-DR	13'-2 3/8"	5,350	3/8	3/8	3/8	1/2	5/8	5/8
6	(2) 3-DR	15'-10"	6,420	3/8	3/8	3/8	5/8	5/8	5/8
7	(1) 3-DR & (1) 4-DR	18'-4 7/16"	7,490	3/8	3/8	3/8	5/8	5/8	7/8
8	(2) 4-DR	20'-10 7/8"	8,560	3/8	3/8	3/8	5/8	7/8	7/8
9	(1) 4-DR & (1) 5-DR	23'-5 5/16"	9,630	3/8	3/8	3/8	5/8	7/8	7/8
10	(2) 5-DR	25'-11 3/4"	10,700	3/8	3/8	3/8	5/8	7/8	7/8
11	(1) 3-DR & (2) 4-DR	28'-7 3/8"	11,770	3/8	3/8	3/8	5/8	7/8	7/8
12	(3) 4-DR	31'-1 13/16"	12,840	3/8	3/8	3/8	7/8	7/8	7/8
13	(2) 4-DR & (1) 5-DR	33'-8 1/4"	13,910	3/8	3/8	3/8	7/8	7/8	7/8
14	(1) 4-DR & (2) 5-DR	36'-2 11/16"	14,980	3/8	3/8	3/8	7/8	7/8	7/8
15	(3) 5-DR	38'-9 1/8"	16,050	3/8	3/8	3/8	7/8	7/8	7/8
16	(4) 4-DR	41'-4 3/4"	17,120	3/8	3/8	1/2	7/8	7/8	7/8
17	(3) 4-DR & (1) 5-DR	43'-11 3/16"	18,190	3/8	3/8	1/2	7/8	7/8	1 1/8
18	(2) 4-DR & (2) 5-DR	46'-5 5/8"	19,260	3/8	3/8	1/2	7/8	7/8	1 1/8
19	(1) 4-DR & (3) 5-DR	49'-1 1/16"	20,330	3/8	3/8	1/2	7/8	7/8	1.1/8
20	(4) 5-DR	51'-6 1/2"	21,400	3/8	1/2	1/2	7/8	7/8	1.1/8
21	(4) 4-DR & (1) 5-DR	54'-2 1/8"	22,470	3/8	1/2	1/2	7/8	1.1/8	1.1/8
22	(3) 4-DR & (2) 5-DR	56'-8 9/16"	23,540	3/8	1/2	1/2	7/8	1.1/8	1.1/8
23	(2) 4-DR & (3) 5-DR	59'-3"	24,610	3/8	1/2	1/2	7/8	1.1/8	1.1/8
24	(1) 4-DR & (4) 5-DR	61'-9 7/16"	25,680	3/8	1/2	1/2	7/8	1.1/8	1.1/8
25	(5) 5-DR	64'-3 7/8"	26,750	3/8	1/2	1/2	7/8	1.1/8	1.1/8
26	(4) 4-DR & (2) 5-DR	66'-11 1/2"	27,820	3/8	1/2	1/2	7/8	1.1/8	1.1/8
27	(3) 4-DR & (3) 5-DR	69'-5 15/16"	28,890	3/8	1/2	1/2	7/8	1.1/8	1.1/8
28	(2) 4-DR & (4) 5-DR	72'-3/8"	29,960	3/8	1/2	1/2	7/8	1.1/8	1.1/8
29	(1) 4-DR & (5) 5-DR	74'-6 13/16"	31,030	1/2	1/2	1/2	7/8	1.1/8	1.1/8
30	(6) 5-DR	77'-1 1/4"	32,100	1/2	1/2	5/8	1.1/8	1.1/8	1.1/8

BTU/HR ARE FOR STANDARD FAN MOTORS, T-8 ELECTRONIC LIGHTING AND PARALLEL RACK SYSTEM. SUBTRACT 57 BTU/HR PER DOOR FOR PSC FAN MOTORS. ADD 30 BTU/HR PER DOOR FOR T-12 LIGHTING. MULTIPLY BY 1.04 FOR CONVENTIONAL SYSTEM. BTU/HR AND LINE SIZES ARE FOR STANDARD DOORS. SPECIFICATIONS FOR ELM DOORS ARE SLIGHTLY DIFFERENT. PLEASE CONSULT FACTORY. CASES DESIGNED TO OPERATE IN AN AMBIENT OF 75°F OR LOWER AND RELATIVE HUMIDITY OF 55% OR LOWER. SHADED CELLS INDICATE VERTICAL SUCTION RISERS NEED TO BE ONE SIZE SMALLER THAN SIZE SHOWN.



Table 2

REMOTE REACH-IN COOLER W/ 30" X 63" DOORS MODEL RMCP30 & RMCP30RL REFRIGERANT R-22 @ 20° F EVAPORATOR									
NO. OF DOORS	COOLER COMBINATIONS	TOTAL LENGTH W/ENDS	BTU/HR	RECOMMENDED LIQUID LINE SIZES EQUIVALENT LENGTH, FEET			RECOMMENDED SUCTION LINE SIZES EQUIVALENT LENGTH, FEET		
				50	100	150	50	100	150
2	(1) 2-DR	5'-7 1/16"	2,735	3/8	3/8	3/8	1/2	1/2	1/2
3	(1) 3-DR	8'-1 1/2"	3,705	3/8	3/8	3/8	1/2	1/2	5/8
4	(1) 4-DR	10'-7 15/16"	4,650	3/8	3/8	3/8	1/2	5/8	5/8
5	(1) 5-DR	13'-2 3/8"	5,625	3/8	3/8	3/8	1/2	5/8	5/8
6	(2) 3-DR	15'-10"	6,750	3/8	3/8	3/8	5/8	5/8	7/8
7	(1) 3-DR & (1) 4-DR	18'-4 7/16"	7,875	3/8	3/8	3/8	5/8	5/8	7/8
8	(2) 4-DR	20'-10 7/8"	9,000	3/8	3/8	3/8	5/8	7/8	7/8
9	(1) 4-DR & (1) 5-DR	23'-5 5/16"	10,125	3/8	3/8	3/8	5/8	7/8	7/8
10	(2) 5-DR	25'-11 3/4"	11,250	3/8	3/8	3/8	5/8	7/8	7/8
11	(1) 3-DR & (2) 4-DR	28'-7 3/8"	12,375	3/8	3/8	3/8	7/8	7/8	7/8
12	(3) 4-DR	31'-1 13/16"	13,500	3/8	3/8	3/8	7/8	7/8	7/8
13	(2) 4-DR & (1) 5-DR	33'-8 1/4"	14,625	3/8	3/8	3/8	7/8	7/8	7/8
14	(1) 4-DR & (2) 5-DR	36'-2 11/16"	15,750	3/8	3/8	3/8	7/8	7/8	7/8
15	(3) 5-DR	38'-9 1/8"	16,875	3/8	3/8	1/2	7/8	7/8	7/8
16	(4) 4-DR	41'-4 3/4"	18,000	3/8	3/8	1/2	7/8	7/8	1 1/8
17	(3) 4-DR & (1) 5-DR	43'-11 3/16"	19,125	3/8	3/8	1/2	7/8	7/8	1 1/8
18	(2) 4-DR & (2) 5-DR	46'-5 5/8"	20,250	3/8	3/8	1/2	7/8	7/8	1 1/8
19	(1) 4-DR & (3) 5-DR	49'-1 1/16"	21,375	3/8	1/2	1/2	7/8	7/8	1 1/8
20	(4) 5-DR	51'-6 1/2"	22,500	3/8	1/2	1/2	7/8	1 1/8	1 1/8
21	(4) 4-DR & (1) 5-DR	54'-2 1/8"	23,625	3/8	1/2	1/2	7/8	1 1/8	1 1/8
22	(3) 4-DR & (2) 5-DR	56'-8 9/16"	24,750	3/8	1/2	1/2	7/8	1 1/8	1 1/8
23	(2) 4-DR & (3) 5-DR	59'-3"	25,875	3/8	1/2	1/2	7/8	1 1/8	1 1/8
24	(1) 4-DR & (4) 5-DR	61'-9 7/16"	27,000	3/8	1/2	1/2	7/8	1 1/8	1 1/8
25	(5) 5-DR	64'-3 7/8"	28,125	3/8	1/2	1/2	7/8	1 1/8	1 1/8
26	(4) 4-DR & (2) 5-DR	66'-11 1/2"	29,250	1/2	1/2	1/2	7/8	1 1/8	1 1/8
27	(3) 4-DR & (3) 5-DR	69'-5 15/16"	30,375	1/2	1/2	1/2	7/8	1 1/8	1 1/8
28	(2) 4-DR & (4) 5-DR	72'-3/8"	31,500	1/2	1/2	5/8	7/8	1 1/8	1 1/8
29	(1) 4-DR & (5) 5-DR	74'-6 13/16"	32,625	1/2	1/2	5/8	1 1/8	1 1/8	1 1/8
30	(6) 5-DR	77'-1 1/4"	33,750	1/2	1/2	5/8	1 1/8	1 1/8	1 1/8

NOTE: BTU/HR RATING BASED ON 800 MA T-12 LIGHTING AND PARALLEL RACK SYSTEM. MULTIPLY BY 1.04 FOR CONVENTIONAL SYSTEM. DEDUCT 30 BTU/DOOR FOR T-8 ELECTRONIC LIGHTING SYSTEM. CASES DESIGNED TO OPERATE IN AN AMBIENT OF 75°F OR LOWER AND RELATIVE HUMIDITY OF 55% OR LOWER. SHADED CELL INDICATES VERTICAL SUCTION RISERS NEED TO BE ONE SIZE SMALLER THAN SIZE SHOWN. REAR LOAD IS FOR ATTACHING TO A WALK-IN COOLER.

RMCC30, RMCP30, RMCP30RL, RMCP30SA, RMCP24  
03035

Table 3



**REMOTE REACH-IN COOLER W/ 30" X 63" DOORS**  
**MODEL RMCP30SA**  
**REFRIGERANT R-22 @ 20° F EVAPORATOR**

NO. OF DOORS	COOLER COMBINATIONS	TOTAL LENGTH W/ENDS	BTU/HR	RECOMMENDED LIQUID LINE SIZES EQUIVALENT LENGTH, FEET			RECOMMENDED SUCTION LINE SIZES EQUIVALENT LENGTH, FEET		
				50	100	150	50	100	150
2	(1) 2-DR	5'-7 1/16"	4,785	3/8	3/8	3/8	1/2	5/8	5/8
3	(1) 3-DR	8'-1 1/2"	6,485	3/8	3/8	3/8	5/8	5/8	5/8
4	(1) 4-DR	10'-7 15/16"	8,140	3/8	3/8	3/8	5/8	5/8	7/8
5	(1) 5-DR	13'-2 3/8"	9,845	3/8	3/8	3/8	5/8	7/8	7/8
6	(2) 3-DR	15'-10"	11,814	3/8	3/8	3/8	5/8	7/8	7/8
7	(1) 3-DR & (1) 4-DR	18'-4 7/16"	13,783	3/8	3/8	3/8	7/8	7/8	7/8
8	(2) 4-DR	20'-10 7/8"	15,752	3/8	3/8	3/8	7/8	7/8	7/8
9	(1) 4-DR & (1) 5-DR	23'-5 5/16"	17,721	3/8	3/8	1/2	7/8	7/8	1 1/8
10	(2) 5-DR	25'-11 3/4"	19,690	3/8	3/8	1/2	7/8	7/8	1 1/8
11	(1) 3-DR & (2) 4-DR	28'-7 3/8"	21,659	3/8	1/2	1/2	7/8	7/8	1 1/8
12	(3) 4-DR	31'-1 13/16"	23,628	3/8	1/2	1/2	7/8	1 1/8	1 1/8
13	(2) 4-DR & (1) 5-DR	33'-8 1/4"	25,597	3/8	1/2	1/2	7/8	1 1/8	1 1/8
14	(1) 4-DR & (2) 5-DR	36'-2 11/16"	27,566	3/8	1/2	1/2	7/8	1 1/8	1 1/8
15	(3) 5-DR	38'-9 1/8"	29,535	3/8	1/2	1/2	7/8	1 1/8	1 1/8
16	(4) 4-DR	41'-4 3/4"	31,504	1/2	1/2	5/8	7/8	1 1/8	1 1/8
17	(3) 4-DR & (1) 5-DR	43'-11 3/16"	33,473	1/2	1/2	5/8	1 1/8	1 1/8	1 1/8
18	(2) 4-DR & (2) 5-DR	46'-5 5/8"	35,442	1/2	1/2	5/8	1 1/8	1 1/8	1 3/8
19	(1) 4-DR & (3) 5-DR	49'-1 1/16"	37,411	1/2	1/2	5/8	1 1/8	1 1/8	1 3/8
20	(4) 5-DR	51'-6 1/2"	39,380	1/2	5/8	5/8	1 1/8	1 1/8	1 3/8
21	(4) 4-DR & (1) 5-DR	54'-2 1/8"	41,349	1/2	5/8	5/8	1 1/8	1 1/8	1 3/8
22	(3) 4-DR & (2) 5-DR	56'-8 9/16"	43,318	1/2	5/8	5/8	1 1/8	1 1/8	1 3/8
23	(2) 4-DR & (3) 5-DR	59'-3"	45,287	1/2	5/8	5/8	1 1/8	1 3/8	1 3/8
24	(1) 4-DR & (4) 5-DR	61'-9 7/16"	47,256	1/2	5/8	5/8	1 1/8	1 3/8	1 3/8
25	(5) 5-DR	64'-3 7/8"	49,225	1/2	5/8	5/8	1 1/8	1 3/8	1 3/8
26	(4) 4-DR & (2) 5-DR	66'-11 1/2"	51,194	1/2	5/8	5/8	1 1/8	1 3/8	1 3/8
27	(3) 4-DR & (3) 5-DR	69'-5 15/16"	53,163	1/2	5/8	5/8	1 1/8	1 3/8	1 3/8
28	(2) 4-DR & (4) 5-DR	72'-3/8"	55,132	1/2	5/8	5/8	1 1/8	1 3/8	1 3/8
29	(1) 4-DR & (5) 5-DR	74'-6 13/16"	57,101	1/2	5/8	5/8	1 1/8	1 3/8	1 3/8
30	(6) 5-DR	77'-1 1/4"	59,070	5/8	5/8	7/8	1 1/8	1 3/8	1 3/8

NOTE: BTU/HR RATING BASED ON 800 MA T-12 LIGHTING AND PARALLEL RACK SYSTEM. MULTIPLY BY 1.04 FOR CONVENTIONAL SYSTEM. DEDUCT 30 BTU/DOOR FOR T-8 ELECTRONIC LIGHTING SYSTEM. CASES DESIGNED TO OPERATE IN AN AMBIENT OF 75°F OR LOWER AND RELATIVE HUMIDITY OF 55% OR LOWER. SHADED CELL INDICATES VERTICAL SUCTION RISERS NEED TO BE ONE SIZE SMALLER THAN SIZE SHOWN.



Table 4

**REMOTE REACH-IN COOLER W/ 24" X 63" DOORS  
MODEL RMCC24 WITH STANDARD DOORS  
REFRIGERANT R-22 @ +25°F EVAPORATOR TEMPERATURE**

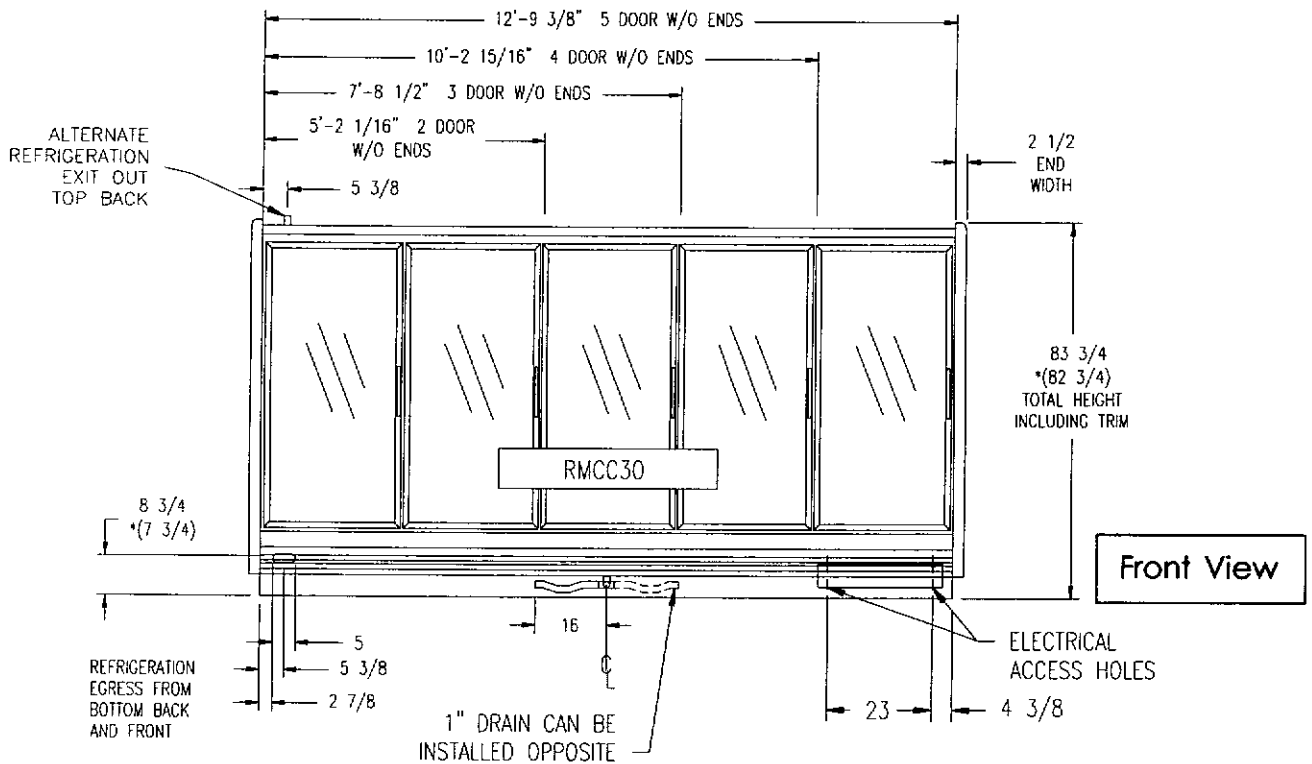
NO. OF DOORS	FREEZER COMBINATIONS	TOTAL LENGTH W/ENDS	BTU/HR	RECOMMENDED LIQUID LINE SIZES EQUIVALENT LENGTH, FEET			RECOMMENDED SUCTION LINE SIZES EQUIVALENT LENGTH, FEET		
				50	100	150	50	100	150
2	(1) 2-DR	4' - 5 9/16"	2,330	3/8	3/8	3/8	1/2	1/2	1/2
3	(1) 3-DR	6' - 5 7/16"	3,225	3/8	3/8	3/8	1/2	1/2	1/2
4	(2) 2-DR	8' - 6 1/8"	4,460	3/8	3/8	3/8	1/2	5/8	5/8
5	(1) 2-DR & (1) 3-DR	10' - 6"	5,250	3/8	3/8	3/8	1/2	5/8	5/8
6	(2) 3-DR	12' - 5 7/8"	6,300	3/8	3/8	3/8	1/2	5/8	5/8
7	(2) 2-DR & (1) 3-DR	14' - 6 9/16"	7,350	3/8	3/8	3/8	5/8	5/8	7/8
8	(1) 2-DR & (2) 3-DR	16' - 6 7/16"	8,400	3/8	3/8	3/8	5/8	7/8	7/8
9	(3) 3-DR	18' - 6 5/16"	9,450	3/8	3/8	3/8	5/8	7/8	7/8
10	(2) 2-DR & (2) 3-DR	20' - 7"	10,500	3/8	3/8	3/8	5/8	7/8	7/8
11	(1) 2-DR & (3) 3-DR	22' - 6 7/8"	11,550	3/8	3/8	3/8	5/8	7/8	7/8
12	(4) 3-DR	24' - 6 3/4"	12,600	3/8	3/8	3/8	7/8	7/8	7/8
13	(2) 2-DR & (3) 3-DR	26' - 7 7/16"	13,650	3/8	3/8	3/8	7/8	7/8	7/8
14	(1) 2-DR & (4) 3-DR	28' - 7 5/16"	14,700	3/8	3/8	3/8	7/8	7/8	7/8
15	(5) 3-DR	30' - 7 3/16"	15,750	3/8	3/8	3/8	7/8	7/8	7/8
16	(2) 2-DR & (4) 3-DR	32' - 7 7/8"	16,800	3/8	3/8	1/2	7/8	7/8	7/8
17	(1) 2-DR & (5) 3-DR	34' - 7 3/4"	17,850	3/8	3/8	1/2	7/8	7/8	7/8
18	(6) 3-DR	36' - 7 5/8"	18,900	3/8	3/8	1/2	7/8	7/8	7/8
19	(2) 2-DR & (5) 3-DR	38' - 8 5/16"	19,950	3/8	3/8	1/2	7/8	7/8	1.1/8
20	(1) 2-DR & (6) 3-DR	40' - 8 3/16"	21,000	3/8	1/2	1/2	7/8	7/8	1.1/8

BTU/HR ARE FOR STANDARD FAN MOTORS, T-8 ELECTRONIC LIGHTING AND PARALLEL RACK SYSTEM. SUBTRACT 57 BTU/HR PER DOOR FOR PSC FAN MOTORS. ADD 30 BTU/HR PER DOOR FOR T-12 LIGHTING. MULTIPLY BY 1.04 FOR CONVENTIONAL SYSTEM. BTU/HR AND LINE SIZES ARE FOR STANDARD DOORS. SPECIFICATIONS FOR ELM DOORS ARE SLIGHTLY DIFFERENT. PLEASE CONSULT FACTORY. CASES DESIGNED TO OPERATE IN AN AMBIENT OF 75°F OR LOWER AND RELATIVE HUMIDITY OF 55% OR LOWER. SHADED CELLS INDICATE VERTICAL SUCTION RISERS NEED TO BE ONE SIZE SMALLER THAN SIZE SHOWN.



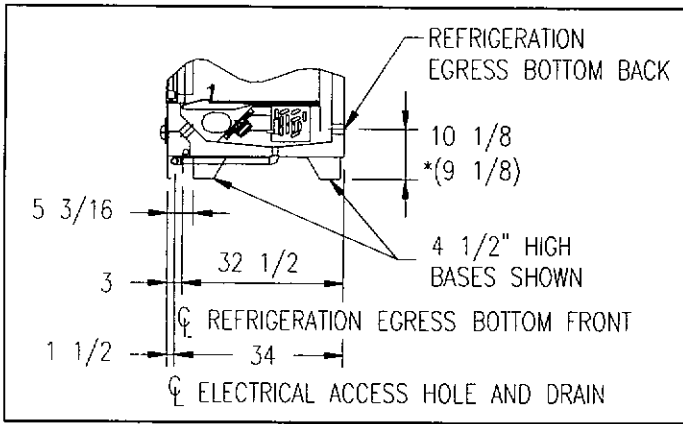
Figure 13

# RMCC30 SPECIFICATION SHEET

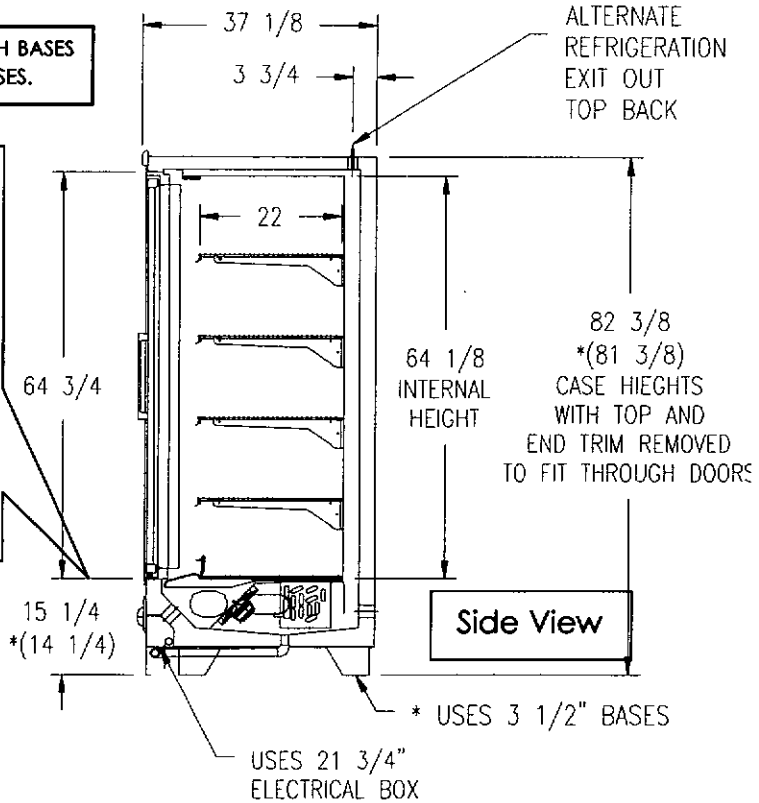


Front View

\* NOTE: CASE DIMENSIONS SHOWN REFLECT STANDARD 4-1/2" HIGH BASES  
 DIMENSIONS SHOWN IN (PARENTESIS) REFLECT 3-1/2" BASES.



Partial Side View (Bottom)



Side View

All specifications are subject to change without notice.

RMCC30, RMCP30, RMCP30RL, RMCP30SA, RMCC24



Figure 13

# RMCC30 SPECIFICATION SHEET

CASE SIZE	EST. WEIGHT IN POUNDS*
2RMCC30	747
3RMCC30	1,037
4RMCC30	1,391
5RMCC30	1,775

\*WEIGHT BASED ON UNCRATED CASES WITHOUT ENDS, AND FULLY SHELVED.  
SINGLE END WEIGHT: 54 POUNDS

REFRIGERANT CONNECTIONS SIZES				CAPACITY SPECIFICATIONS		
MODEL NUMBER	SUCTION LINE O.D.	LIQUID LINE O.D.	SUCTION LINE O.D. FOR REFRIGERATION OUT TOP BACK	MODEL NUMBER	USABLE CUBIC FEET	VERTICAL SURFACE SQUARE FOOTAGE
2RMCC30	7/8	3/8	1/2	2RMCC30	51	28
3RMCC30	7/8	3/8	5/8	3RMCC30	76	41
4RMCC30	7/8	3/8	5/8	4RMCC30	100	55
5RMCC30	7/8	3/8	5/8	5RMCC30	125	68

ELECTRICAL SPECIFICATIONS								
MODEL NUMBER	FANS AMPS	ANTHONY T-8 LIGHT AMPS	T-12 LIGHT AMPS ONE END*	T-12 LIGHT AMPS BOTH ENDS	ANTHONY ELM ANTI-SWEAT HEATERS	ANTHONY STANDARD ANTI-SWEAT HEATERS	ARDCO T-8 LIGHT AMPS	ARDCO STANDARD ANTI-SWEAT HEATERS
2RMCC30	0.68	1.45	1.65	2.40	0.55	2.10	1.89	1.16
3RMCC30	1.02	1.94	2.40	3.30	0.79	3.06	2.34	1.64
4RMCC30	1.36	2.42	3.30	4.05	1.03	3.91	3.06	2.13
5RMCC30	1.70	2.91	4.05	4.80	1.28	4.93	3.51	2.60

SUBTRACT 0.19 AMPS PER DOOR FOR PSC FAN MOTORS  
SUBTRACT 0.36 AMPS PER DOOR FOR ANTHONY FRAMELESS DOORS  
VOLTAGE: 115 VOLTS 1 PHASE 60 HZ.  
\* STANDARD FOR CASE IN A LINE-UP

BTU/HR ENERGY REQUIREMENTS: FOR PRODUCT TEMPERATURE OF 33°F TO 41°F WITH 25°F EVAPORATOR		
# OF DOORS	BTU/HR @ +25°F	BTU/HR RATING BASED ON T-8 LIGHTING AND PARALLEL RACK SYSTEM.
2	2,490	ADD 30 BTU/HR PER DOOR FOR T-12 LIGHTING DEDUCT 57 BTU/HR PER DOOR FOR PSC FAN MOTORS CASE DESIGNED TO OPERATE IN AN AMBIENT OF 75°F OR LOWER AND RELATIVE HUMIDITY OF 55% OR LOWER
3	3,460	
4	4,450	
5	5,450	
RMCC30 W/OPTIONAL ELM DOORS	FOR ELM AT +25°F DEDUCT 320 BTU/HR/DOOR (PRELIMINARY)	



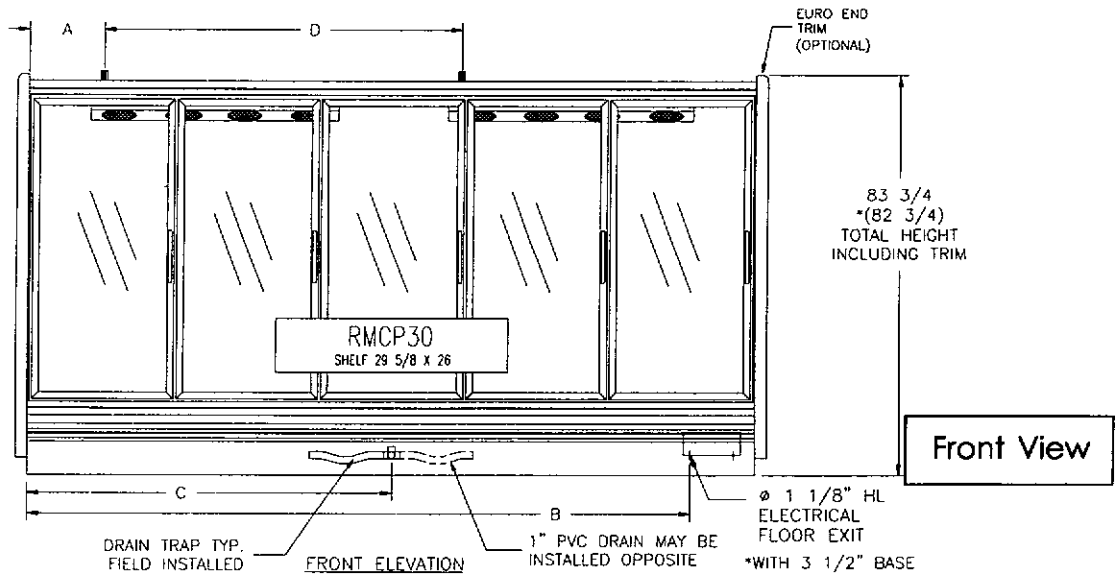
All specifications are subject to change without notice.

RMCC30, RMCP30, RMCP30RL, RMCP30SA, RMCC24

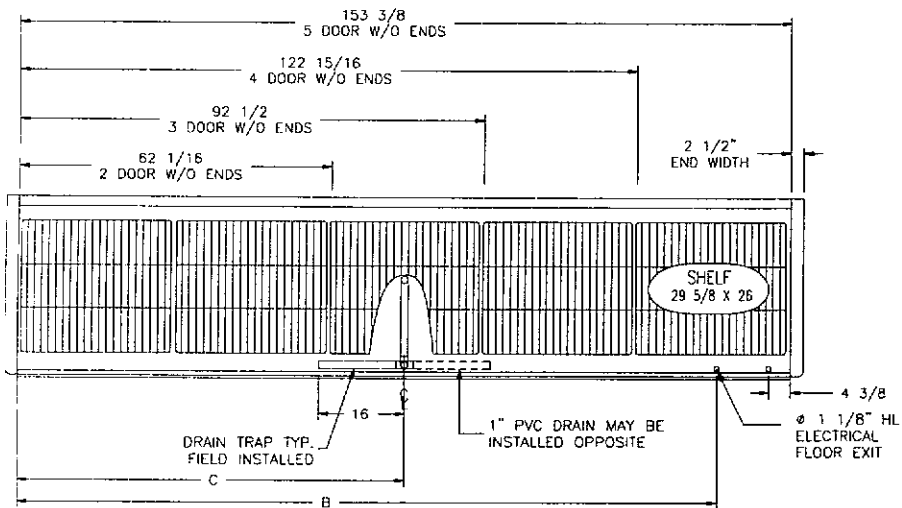


Figure 14

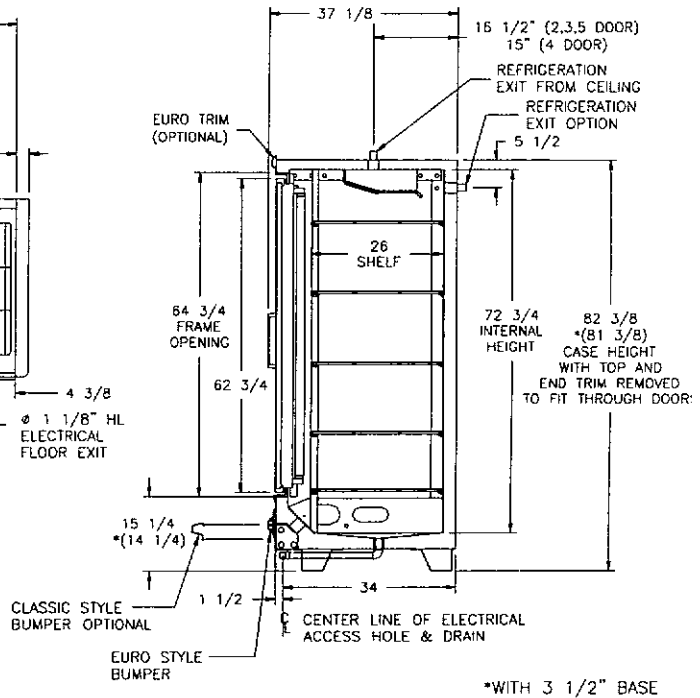
# RMCP30 SPECIFICATION SHEET



Front View



Top View  
Shown in Section  
5RMCP30



Side View

\* NOTE: CASE DIMENSIONS SHOWN REFLECT STANDARD 4-1/2" HIGH BASES  
DIMENSIONS SHOWN IN (PARENTHESIS) REFLECT 3-1/2" BASES.

All specifications are subject to change without notice.



Figure 14

# RMCP30 SPECIFICATION SHEET

ELECTRICAL CONNECTION (B) & DRAIN (C) LOCATION SCHEDULE		
MODEL NUMBER	B	C
2RMCP30	48 5/8	31
3RMCP30	79 1/16	46 1/4
4RMCP30	109 1/2	61 1/2
5RMCP30	139 15/16	76 11/16

RMCP30 CAPACITY SPECIFICATIONS			
CASE SIZE	SHELVING 29-5/8X 26"	CUBIC FEET CAPACITIES	EST. WEIGHT*
	GROSS SQ. FT.	GROSS CUBIC FT.	POUNDS
2	53.50	66.0	575
3	80.25	98.3	873
4	107.00	130.6	1128
5	133.75	163.0	1440

WEIGHT BASED ON UNCRATED CASES WITHOUT ENDS, AND FULLY SHELVED. SINGLE END WEIGHT: 54#

REFRIGERATION LOCATION SCHEDULE				
MODEL NUMBER	A	D	CONNECTIONS	
			INLET	SUCTION
2RMCP30	14	n/a	3/8 OD	5/8 OD
3RMCP30	29	n/a	3/8 OD	5/8 OD
4RMCP30	37	n/a	3/8 OD	5/8 OD
5RMCP30	26	67	3/8 OD	5/8 OD

ELECTRICAL SPECIFICATIONS BY DOOR MANUFACTURER									
MODEL NUMBER	FANS AMPS	T-12 LIGHT AMPS ONE END*	T-12 LIGHT AMPS BOTH ENDS	T-8 LIGHT AMPS	STD. DOOR	MULLION	FRAME	FRAMELESS DOOR	TOTAL FRAME MULLION STD. DOOR
<b>ANTHONY DOORS</b>									
2RMCP30	2.4	1.65	2.4	1.45	0.72	0.43	0.95	0	2.10
3RMCP30	3.2	2.4	3.3	1.94	1.08	0.86	1.12	0	3.06
4RMCP30	4	3.3	4.05	2.42	1.44	1.29	1.18	0	3.91
5RMCP30	4.8	4.05	4.8	2.91	1.8	1.72	1.41	0	4.93
<b>ARDCO DOORS</b>									
2RMCP30	2.4	1.65	2.4	1.89	0.26	0.54	0.36	0	1.16
3RMCP30	3.2	2.4	3.3	2.34	0.39	0.81	0.44	0	1.64
4RMCP30	4	3.3	4.05	3.06	0.52	1.08	0.53	0	2.13
5RMCP30	4.8	4.05	4.8	3.51	0.65	1.35	0.6	0	2.6
* STANDARD FOR CASE IN A LINE-UP									
VOLTAGE: 115 VOLTS 1 PHASE 60 HZ.									
BTU/HR ENERGY REQUIREMENTS: FOR PRODUCT TEMPERATURE OF 37°F TO 45°F WITH 20°F EVAPORATOR									
# OF DOORS	BTU/HR	BTU/HR RATING BASED ON 800 MA T-12 LIGHTING AND PARALLEL							
2	2735	CASE DESIGNED TO OPERATE IN AN AMBIENT OF 75°F OR LOWER AND RELATIVE HUMIDITY OF 55% OR LOWER							
3	3705								
4	4650								
5	5625								



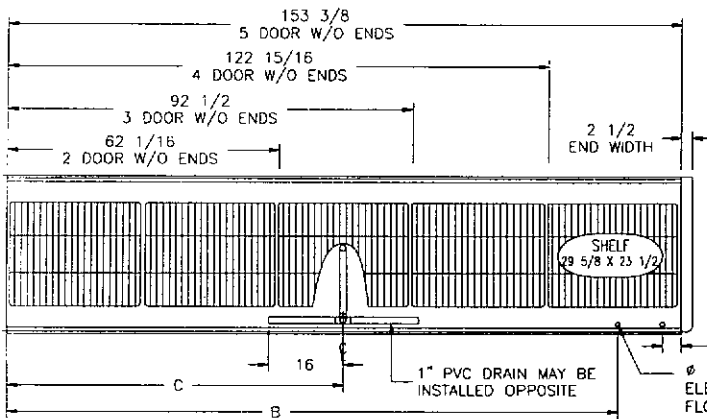
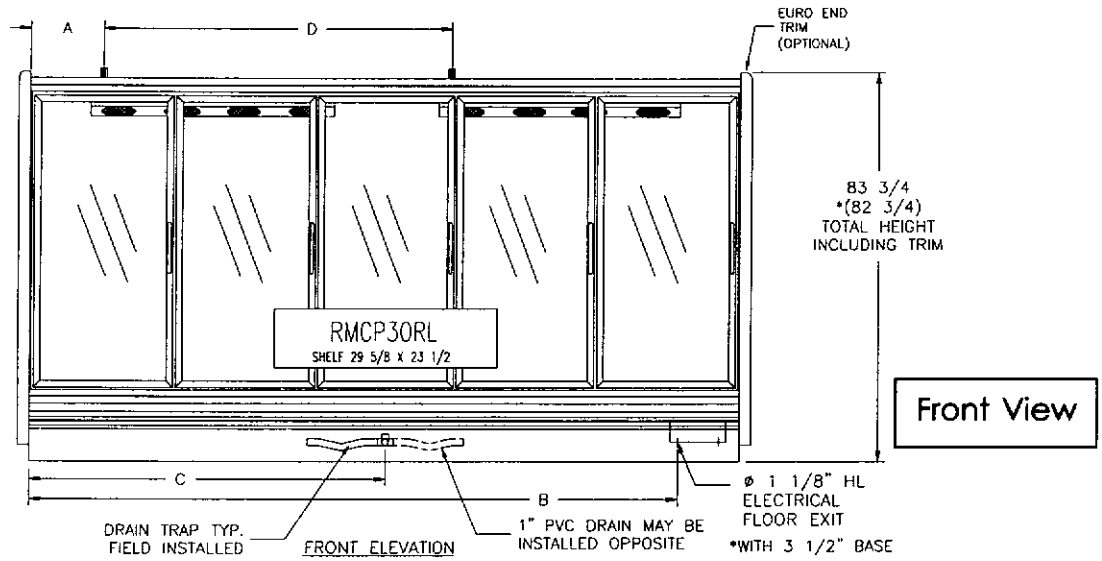
All specifications are subject to change without notice.



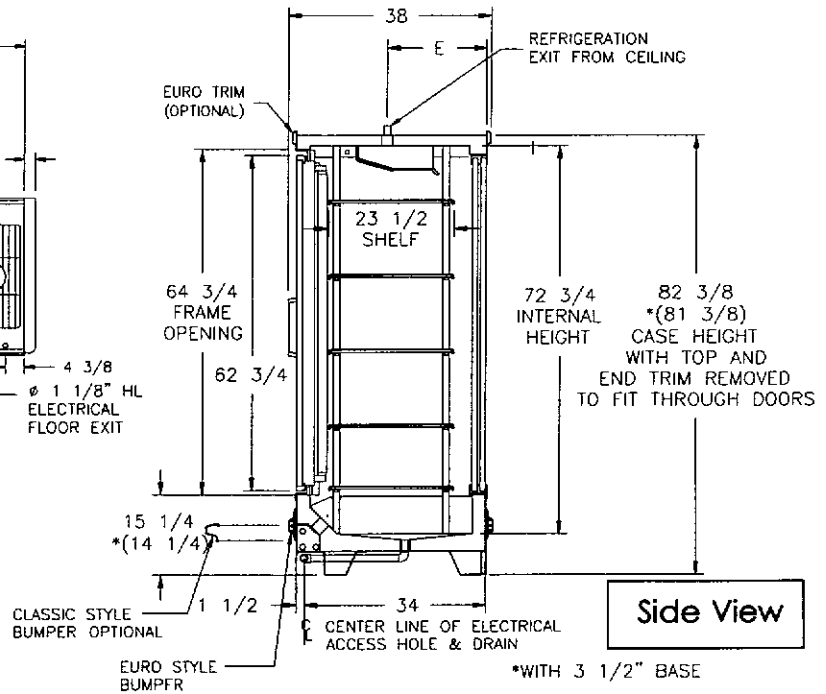


Figure 15

# RMCP30RL SPECIFICATION SHEET



**Top View  
Shown in Section  
5RMCP30RL**



\* NOTE: CASE DIMENSIONS SHOWN REFLECT STANDARD 4-1/2" HIGH BASES  
DIMENSIONS SHOWN IN (PARENTHESES) REFLECT 3-1/2" BASES.

All specifications are subject to change without notice.

RMCC30, RMCP30, RMCP30RL, RMCP30SA, RMCC24



Figure 15

# RMCP30RL SPECIFICATION SHEET

ELECTRICAL CONNECTION (B) & DRAIN (C) LOCATION SCHEDULE		
MODEL NUMBER	B	C
2RMCP30RL	48 5/8	31
3RMCP30RL	79 1/16	46 1/4
4RMCP30RL	109 1/2	61 1/2
5RMCP30RL	139 15/16	76 11/16

RMCP30RL CAPACITY SPECIFICATIONS			
CASE SIZE	SHELVING	CUBIC FEET CAPACITIES	WEIGHT*
	29-5/8X 23-1/2" GROSS SQ. FT.	GROSS CUBIC FT.	POUNDS
2	48.3	59.6	575
3	72.5	88.8	873
4	96.6	118.1	1128
5	120.8	147.3	1440

WEIGHT BASED ON UNCRATED CASES WITHOUT ENDS, AND FULLY SHELVED.  
SINGLE END WEIGHT: 54#

MODEL NUMBER	A	D	E	CONNECTIONS	
				INLET	SUCTION
2RMCP30RL	13 11/16	-	18 5/8	3/8 OD	5/8 OD
3RMCP30RL	21 7/8	-	18 1/2	3/8 OD	5/8 OD
4RMCP30RL	37 1/16	-	17 3/8	3/8 OD	5/8 OD
5RMCP30RL	25 11/16	67 3/8	18 5/8	3/8 OD	5/8 OD

ELECTRICAL SPECIFICATIONS BY DOOR MANUFACTURER									
MODEL NUMBER	FANS AMPS	T-12 LIGHT AMPS ONE END*	T-12 LIGHT AMPS BOTH ENDS	T-8 LIGHT AMPS	STD. DOOR	MULLION	FRAME	TOTAL OF REAR DOORS AND REAR FRAME	TOTAL FRAME MULLION STD. DOOR
<b>ANTHONY DOORS</b>									
2RMCP30RL	2.4	1.65	2.4	1.45	0.72	0.43	0.95	1.23	3.33
3RMCP30RL	3.2	2.4	3.3	1.94	1.08	0.86	1.12	1.71	4.77
4RMCP30RL	4	3.3	4.05	2.42	1.44	1.29	1.18	2.46	6.37
5RMCP30RL	4.8	4.05	4.8	2.91	1.8	1.72	1.41	2.91	7.84
<b>ARDCO DOORS</b>									
2RMCP30RL	2.4	1.65	2.4	1.89	0.26	0.54	0.36	0	1.16
3RMCP30RL	3.2	2.4	3.3	2.34	0.39	0.81	0.44	0	1.64
4RMCP30RL	4	3.3	4.05	3.06	0.52	1.08	0.53	0	2.13
5RMCP30RL	4.8	4.05	4.8	3.51	0.65	1.35	0.6	0	2.6
* STANDARD FOR CASE IN A LINE-UP									
VOLTAGE: 115 VOLTS 1 PHASE 60 HZ.									
BTU/HR ENERGY REQUIREMENTS: FOR PRODUCT TEMPERATURE OF 37°F TO 41°F WITH 20°F EVAPORATOR									
# OF DOORS	BTU/HR	BTU/HR RATING BASED ON 800 MA T-12 LIGHTING AND PARALLEL							
2	2735	CASE DESIGNED TO OPERATE IN AN AMBIENT OF 75°F OR LOWER AND RELATIVE HUMIDITY OF 55% OR LOWER. RATINGS ARE FOR A CASE ATTACHED TO A WALK IN COOLER. FOR OTHER APPLICATIONS PLEASE CONSULT THE FACTORY							
3	3705								
4	4650								
5	5625								

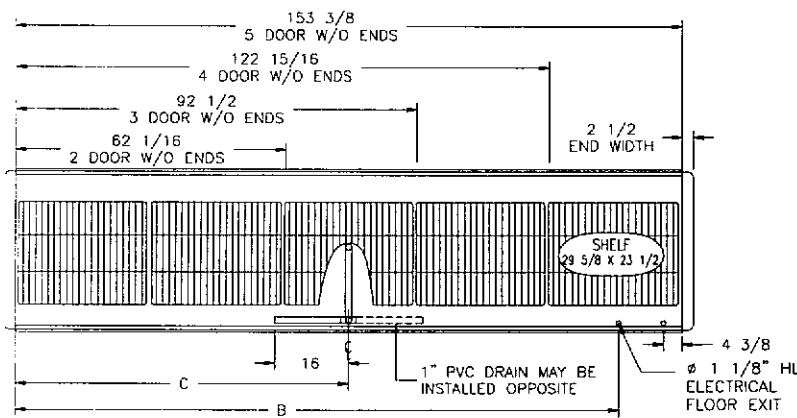
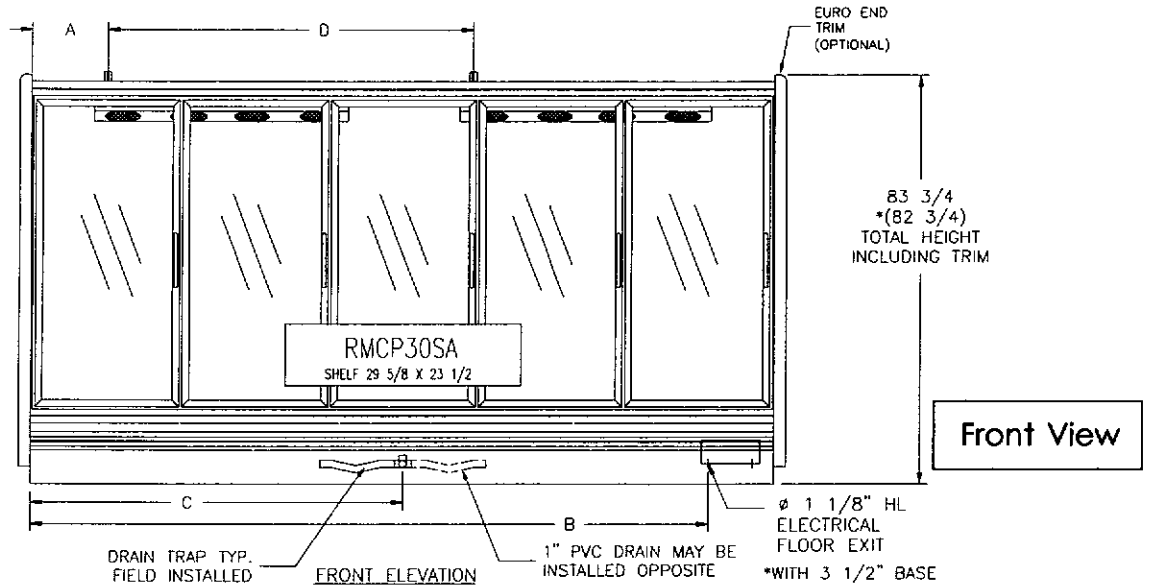


All specifications are subject to change without notice.

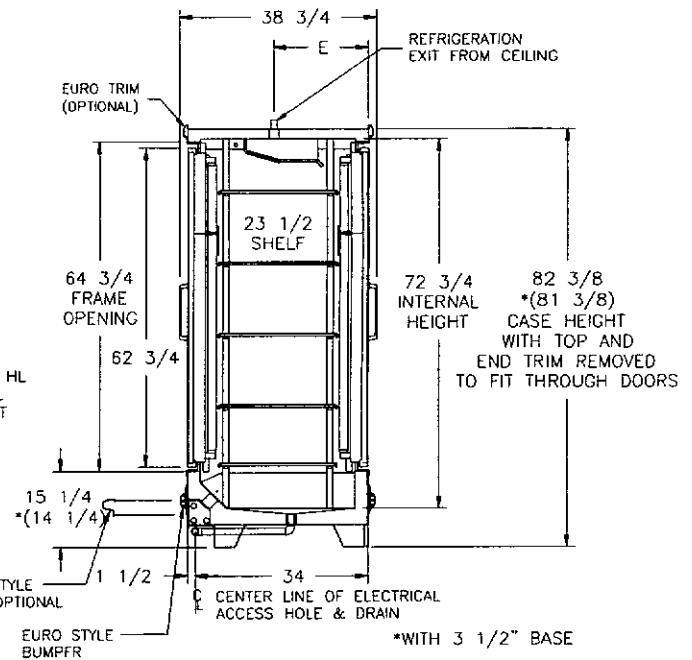


Figure 16

# RMCP30SA SPECIFICATION SHEET



Top View  
Shown in Section  
5RMCP30SA



Side View

\* NOTE: CASE DIMENSIONS SHOWN REFLECT STANDARD 4-1/2" HIGH BASES  
DIMENSIONS SHOWN IN (PARENTHESIS) REFLECT 3-1/2" BASES.

All specifications are subject to change without notice.

RMCC30, RMCP30, RMCP30RL, RMCP30SA, RMCC24

03035



Figure 16

# RMCP30SA SPECIFICATION SHEET

ELECTRICAL CONNECTION (B) & DRAIN (C) LOCATION SCHEDULE		
MODEL NUMBER	B	C
2RMCP30SA	48 5/8	31
3RMCP30SA	79 1/16	46 1/4
4RMCP30SA	109 1/2	61 1/2
5RMCP30SA	139 15/16	76 11/16

RMCP30SA CAPACITY SPECIFICATIONS			
CASE SIZE	SHELVING 29-5/8X 23-	CUBIC FEET CAPACITIES	WEIGHT*
	GROSS SQ. FT.	GROSS CUBIC FT.	POUNDS
2	48.3	59.6	625
3	72.5	88.8	923
4	96.6	118.1	1,178
5	120.8	147.3	1,490
WEIGHT BASED ON UNCRATED CASES WITHOUT ENDS, AND FULLY SHELVED. SINGLE END WEIGHT: 54#			

MODEL NUMBER	A	D	E	CONNECTIONS	
				INLET	SUCTION
2RMCP30SA	6 11/16	-	18 1/2	3/8 OD	5/8 OD
3RMCP30SA	21 7/8	-	17 3/8	3/8 OD	5/8 OD
4RMCP30SA	14 11/16	45 3/16	18 5/8	3/8 OD	5/8 OD
5RMCP30SA	17 5/16	70	18 1/2	3/8 OD	5/8 OD

ELECTRICAL SPECIFICATIONS BY DOOR MANUFACTURER									
MODEL NUMBER	FANS AMPS	T-12 LIGHT AMPS ONE END*	T-12 LIGHT AMPS BOTH ENDS	T-8 LIGHT AMPS	STD. DOOR	MULLION	FRAME	FRAMELESS DOOR	TOTAL FRAME MULLION STD. DOOR
<b>ANTHONY DOORS</b>									
2RMCP30SA	2.4	3.3	4.8	2.9	1.44	0.86	1.9	0	4.20
3RMCP30SA	4	4.8	6.6	3.88	2.16	1.72	2.24	0	6.12
4RMCP30SA	5.6	6.6	8.1	4.84	2.88	2.58	2.36	0	7.82
5RMCP30SA	6.4	8.1	9.6	5.82	3.6	3.44	2.82	0	9.86
<b>ARDCO DOORS</b>									
2RMCP30SA	2.4	3.3	4.8	3.78	0.52	1.08	0.72	0	2.32
3RMCP30SA	4	4.8	6.6	4.68	0.78	1.62	0.88	0	3.28
4RMCP30SA	5.6	6.6	8.1	6.12	1.04	2.16	1.06	0	4.26
5RMCP30SA	6.4	8.1	9.6	7.02	1.3	2.7	1.2	0	5.2
* STANDARD FOR CASE IN A LINE-UP									
VOLTAGE: 115 VOLTS 1 PHASE 60 HZ.									
BTU/HR ENERGY REQUIREMENTS: FOR PRODUCT TEMPERATURE OF 37°F TO 41°F WITH 20°F EVAPORATOR									
# OF DOORS	BTU/HR	BTU/HR RATING BASED ON 800 MA T-12 LIGHTING AND PARALLEL							
2	4,785	CASE DESIGNED TO OPERATE IN AN AMBIENT OF 75°F OR LOWER AND RELATIVE HUMIDITY OF 55% OR LOWER							
3	6,485								
4	8,140								
5	9,845								

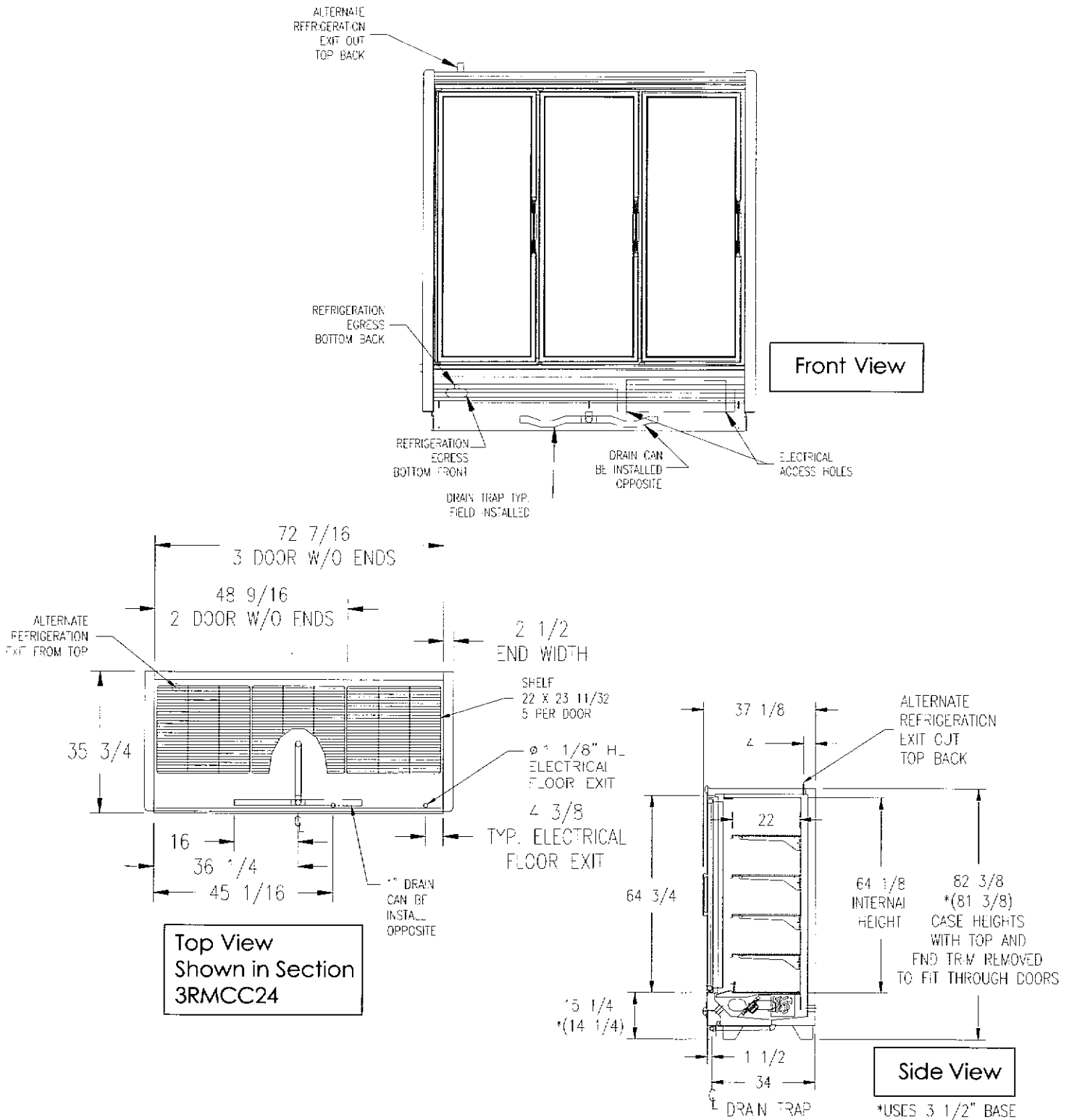


All specifications are subject to change without notice.



Figure 17

# RMCC24 SPECIFICATION SHEET



All specifications are subject to change without notice.

RMCC30, RMCP30, RMCP30RL, RMCP30SA, RMCC24



Figure 17

# RMCC24 SPECIFICATION SHEET

CASE SIZE	EST. WEIGHT IN POUNDS*
2RMCC24	553
3RMCC24	797

\*WEIGHT BASED ON UNCRATED CASES WITHOUT ENDS, AND FULLY SHELVED.  
SINGLE END WEIGHT: 37 POUNDS

REFRIGERANT CONNECTION SIZES			
MODEL NUMBER	SUCTION LINE O.D.	LIQUID LINE O.D.	SUCTION LINE O.D. FOR REFRIGERATION OUT TOP BACK
2RMCC24	7/8	3/8	1/2
3RMCC24	7/8	3/8	1/2

CAPACITY SPECIFICATIONS		
MODEL NUMBER	USABLE CUBIC FEET	VERTICAL SURFACE SQUARE FOOTAGE
2RMCC24	40	22
3RMCC24	59	32

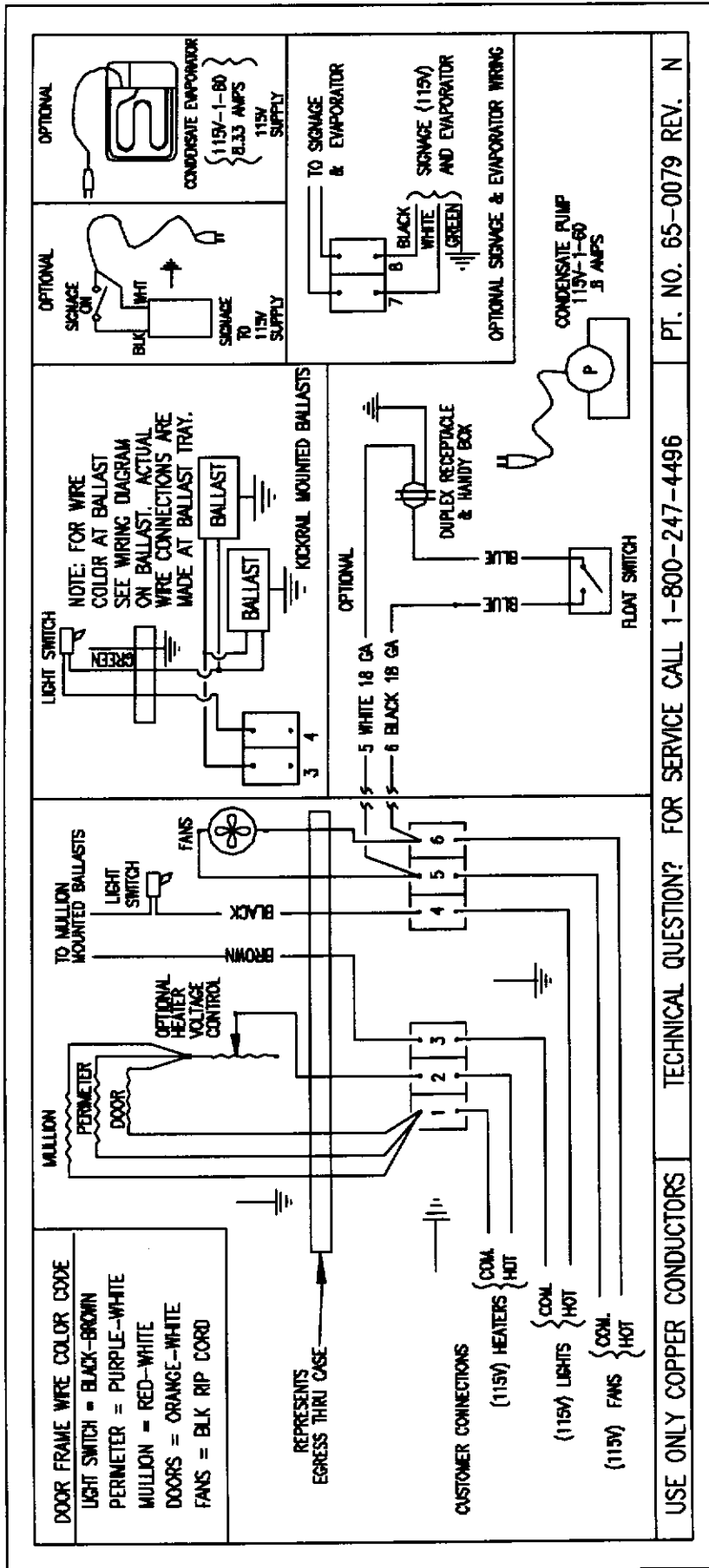
ELECTRICAL SPECIFICATIONS								
MODEL NUMBER	FANS AMPS	ANTHONY T-8 LIGHT AMPS	T-12 LIGHT AMPS ONE END*	T-12 LIGHT AMPS BOTH ENDS	ANTHONY ELM ANTI-SWEAT HEATERS (PRELIMINARY)	ANTHONY STANDARD ANTI-SWEAT HEATERS	ARDCO T-8 LIGHT AMPS	ARDCO STANDARD ANTI-SWEAT HEATERS
2RMCC24	0.68	1.45	1.65	2.40	0.51	1.86	1.89	1.03
3RMCC24	1.02	1.94	2.40	3.30	0.71	2.63	2.34	1.47

SUBTRACT 0.19 AMPS PER DOOR FOR PSC FAN MOTORS  
SUBTRACT 0.30 AMPS PER DOOR FOR ANTHONY FRAMELESS DOORS  
VOLTAGE: 115 VOLTS 1 PHASE 60 HZ.  
\* STANDARD FOR CASE IN A LINE-UP

BTU/HR ENERGY REQUIREMENTS: FOR PRODUCT TEMPERATURE OF 33°F TO 41°F WITH 25°F EVAPORATOR		
# OF DOORS	BTU/HR @ +25°F	BTU/HR RATING BASED ON T-8 LIGHTING AND PARALLEL RACK SYSTEM.
2	2,330	ADD 30 BTU/HR PER DOOR FOR T-12 LIGHTING DEDUCT 57 BTU/HR PER DOOR FOR PSC FAN MOTORS CASE DESIGNED TO OPERATE IN AN AMBIENT OF 75°F OR LOWER AND RELATIVE HUMIDITY OF 55% OR LOWER
3	3,225	
RMCC24 W/OPTIONAL ELM DOORS	FOR ELM AT +25°F DEDUCT 285 BTU/HR/DOOR (PRELIMINARY)	



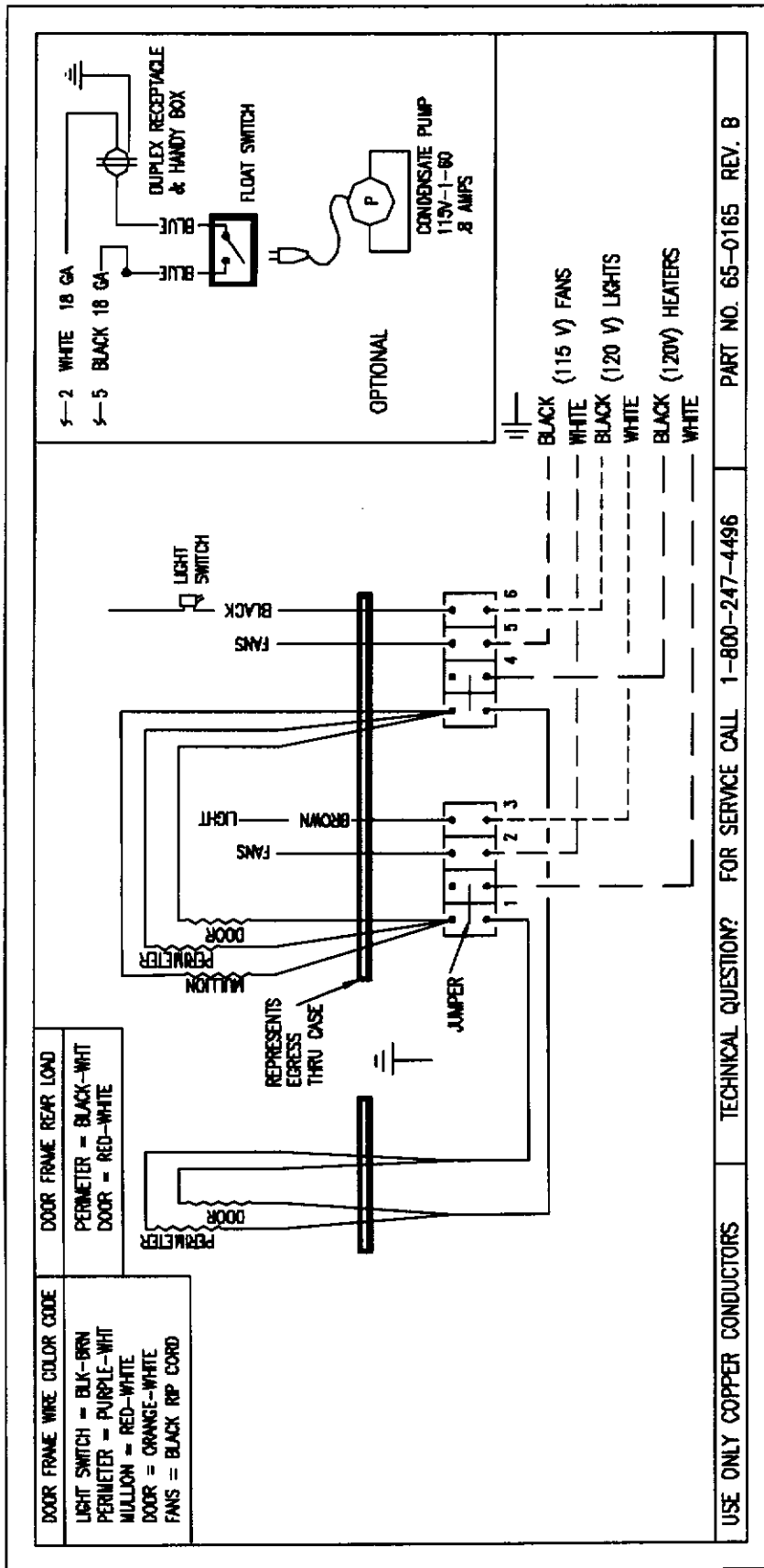
All specifications are subject to change without notice.



PT. NO. 65-0079 REV. N

RMCC30, RMCP30, RMCC24 WIRING DIAGRAM

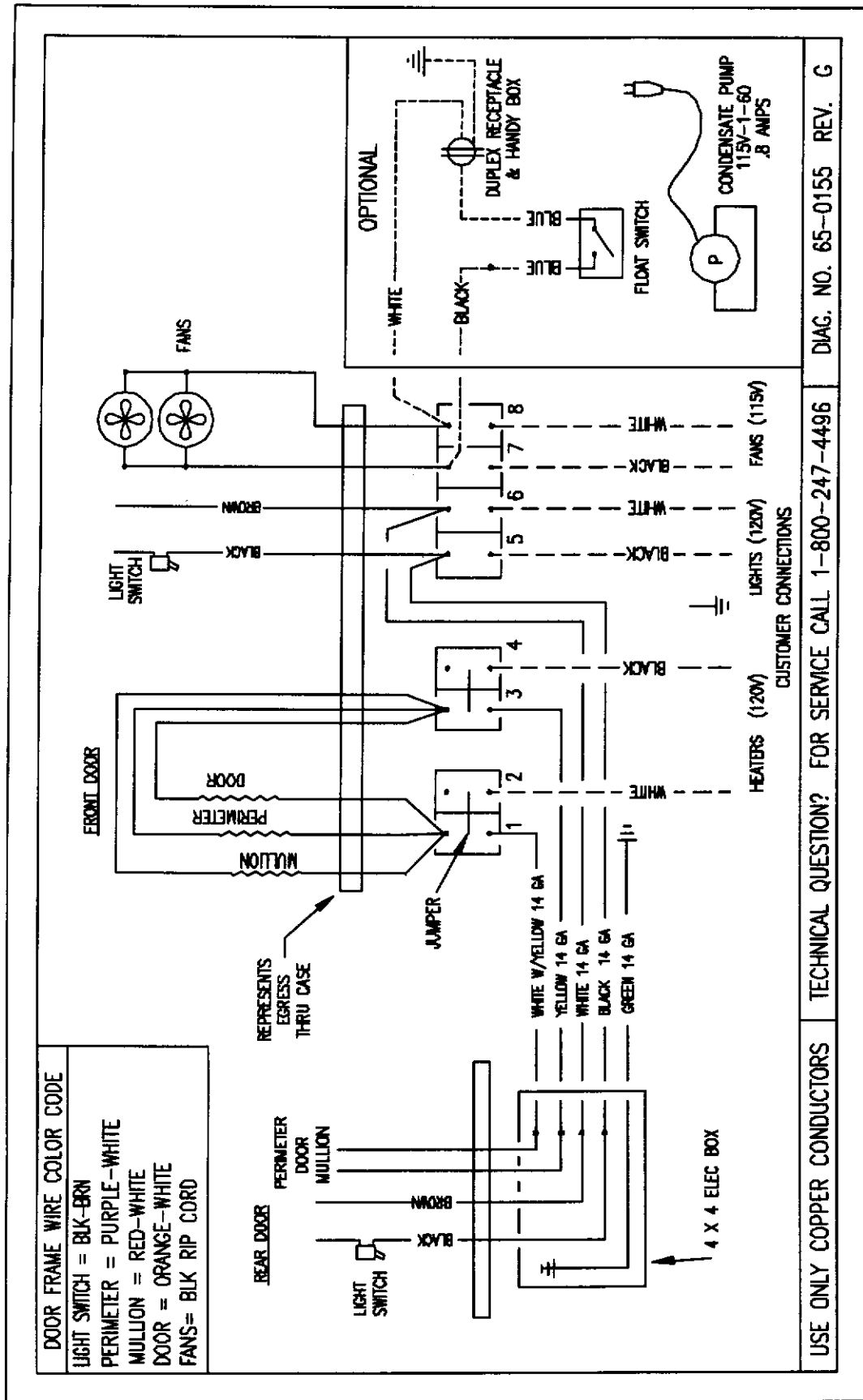
Figure 18



RMCP30RL WIRING DIAGRAM

Figure 19





RMCP30SA WIRING DIAGRAM

Figure 20

•  
•  
•  
•  
•  
•

)

)



1. **Limited Warranty.** ZERO ZONE, INC. ("Seller") hereby warrants that any products manufactured by it and sold under this Warranty shall be free for a period of one year from the date of shipment, from defects in material and workmanship which, under normal use and service would render such products unusable or unserviceable. The obligation of Seller under this Warranty shall be limited to the repair or replacement of any parts that the Seller determines are defective. This Limited Warranty does not cover labor, freight, transportation or other charges incidental to replacement or repair. Parts returned to Seller must be returned freight prepaid and replacement parts will be returned to the Buyer freight collect.
2. **Motor Compressor Extended Warranty.** Seller hereby warrants with respect to any motor compressor sold under this extended Warranty, exclusive of any and all parts of the condensing unit assembly thereof, that such motor compressor shall be free from defects in material and workmanship for a period of four (4) years from the date of the expiration of the one year Warranty provided by the manufacturer of such motor compressor, if the Buyer purchases said Warranty at the time of equipment purchase. In the event the motor compressor is not free from defects in material and/or workmanship during such four-year period, Buyer must purchase a replacement for the defective motor compressor and obtain whatever salvage credit may be available from the manufacturer thereof. Upon receipt by Seller or written notice from Buyer of compressor. Seller will issue a purchase credit or a refund, at Seller's option, for the difference between the compressor replacement cost and the salvage credit. All labor and shipping charges incurred in connection with such replacement shall be the sole obligation of the Buyer.
3. **Product Not Manufactured by Seller.** The written Warranty, if any, provided by the manufacturer of any part of the refrigeration unit sold by Seller to Buyer, but not manufactured by Seller, is hereby assigned to Buyer. However, Seller makes no representation or Warranty regarding the existence, validity or enforceability of any such written Warranty.
4. **LIMITATION AND EXCLUSION OF WARRANTIES.** THE WARRANTIES SET FORTH HEREIN ARE EXCLUSIVE AND IN LIEU OF ALL OTHER WARRANTIES AND REMEDIES WHATSOEVER, INCLUDING BUT NOT LIMITED TO, IMPLIED WARRANTIES OF MERCHANTABILITY AND/OR FITNESS FOR A PARTICULAR PURPOSE.
5. **Consequential Damages.** Notwithstanding anything to the contrary set forth in this Warranty Certificate, Seller shall not be liable for any incidental or consequential damages arising out of, or directly or indirectly caused by a defective part sold by Seller, including but not limited to, costs arising from the replacement of the part, loss of gas, loss of product, or any damage to person or property, whether as a result of Seller's negligence, breach of contract, breach of Warranty or otherwise.

Model No. \_\_\_\_\_ Serial No. \_\_\_\_\_

RMCC30, RMCP30, RMCP30RL, RMCP30SA, RMCC24

11

12

13