



INSTALLATION and OPERATING INSTRUCTIONS for

OMC Series



OMC-LB Series



OMC-SL Series



*S*pecialty
Merchandisers



CRMA
Certified



TABLE OF CONTENTS

SUBJECT	
GENERAL INFORMATION	1
INTRODUCTION	1
INSPECTION	1
LOCATION	1
INSTALLATION.....	1
OPERATION.....	1
OPERATION	1
DRAINS	2
REFRIGERATION	2
HIGH PRESSURE CUT-OUT.....	2
TEMPERATURE CONTROL	2-3
THERMOMETER	3
ELECTRICAL	3
DEFROST	3
USER INFORMATION.....	3
CLEANING	3
SHELVING	3
LOADING	3-4
SERVICE	4
EXPANSION VALVE	4
LAMPS	4
ALARMS	4
FIGURES	5-8
FIGURE 1 SUMMARY OF PARAMETERS.....	5
FIGURE 2 CHANGING PARAMETERS.....	6-7
FIGURE 3 DESCRIPTION OF THE MAIN ALARM SIGNALS.....	8
WIRING DIAGRAMS.....	9-12
FIGURE 4 OMC-LB.....	9
FIGURE 5 OMC-36 & 48.....	10
FIGURE 6 OMC-72.....	11
FIGURE 7 OMCSL48.....	12
OMC-LB SPECIFICATION SHEET.....	13
OMC SPECIFICATION SHEET.....	14
OMC-SL-48 SPECIFICATION SHEET.....	15
WARRANTY.....	16

GENERAL INFORMATION

Introduction

The information contained in this manual pertains to the self-contained open display merchandisers: OMC-LB, OMC-36, OMC-48, OMC-72, and OMCSL48. These merchandisers are ideal for showcasing prepackaged food products in a safe manner. These display coolers were designed to operate in an air-conditioned store where the temperature is maintained at 75°F or lower and the relative humidity is 55% or lower.

Inspection

These display coolers were carefully factory-tested, inspected and properly packed to ensure delivery in the best possible condition. The equipment should be uncrated and checked for damage immediately upon delivery. **ALL CLAIMS FOR DAMAGES MUST BE FILED WITH THE TRANSPORTATION COMPANY - NOT WITH ZERO ZONE.** The carrier will supply necessary report and claim forms.

Location

Position the OMC-LB and OMC units at a minimum of 3-1/2" from walls and other objects that may impede the circulation of air around the exterior of the case. The wall bumper stops supplied for the rear of the OMC-LB and OMC coolers must always remain attached. The OMCSL48 is designed for placement within a lineup of gondola shelving and does not require wall bumper stops.

Do not locate this equipment where it will be exposed to the direct rays of the sun or near a source of radiant heat.

Do not install the display case near doors or areas exposed to air currents.

Do not stack cartons or packaging around the unit that might restrict air circulation to and from the air-cooled condensing unit.

FAILURE TO OBSERVE THIS MAINTENANCE PROCEDURE COULD CAUSE A SIGNIFICANT DECREASE IN REFRIGERATION PERFORMANCE AND INCREASED RUNNING COSTS.

Installation

OMC-LB, OMC-36, OMC-48 and OMC-72 merchandisers must be taken off of the shipping skid and plugged into the proper electrical receptacle. Additionally, because of its shallow profile, the OMCSL48 must be anchored to the shelving uprights or similar support using the brackets shipped with the unit.

OPERATION

Operation

Table 1 on page 4 lists the case model with power and electrical receptacle requirements.

The power switch on the OMC and OMC-LB is located behind the lower front air grill. On the OMCSL48 the power switch is located behind the light box, accessible over the top of the cabinet. The power switch should be off before plugging or unplugging the case. Initially, the evaporator and condenser fans (one on the OMC-LB & OMC-72) will run without the refrigeration compressor(s). After a delay of two minutes, the compressor(s) will start and the case will begin to cool.

All stock must enter the cabinet pre-chilled.

Do not operate with lower rear vent panel removed. This panel has been specifically designed to disperse moisture from the drain tank.

Drains

It is important that the condensate drainage system be kept clear of any obstructions.

Obstructions can be in the form of foreign objects such as loose stock items, dislodged price tags, product labels, etc. Because this cabinet circulates refrigerated air, the entrance of environmental borne dust particles is inevitable. These particles can accumulate in the drainage system and eventually form sludge.

Condensate water drains into a tank, which is designed to evaporate the water. To remove the tank, switch off the power supply, remove the lower front air grill, unplug the electrical socket and slide the tank out the front of the cabinet.

WHEN CLEANING, THE TANK SHOULD NOT BE IMMERSSED IN WATER, AS ELECTRICAL COMPONENTS COULD BE DAMAGED

It is recommended that the condensate drainage system be thoroughly cleaned on a 6-month basis. The need for this may be more frequent, depending on environmental conditions.

Refrigeration

All OMC cases are supplied with a self-contained refrigeration system. The units are factory charged with POE oil and R404a refrigerant.

Refrigerant charges are as follows:

OMC-36	3.86 lbs
OMC-48	4.40 lbs
OMC-72	(2) 3.86 lbs ea.
OMC-LB	3.86 lbs.
OMCSL48	5.00 lbs.

All valves and adjustments to the refrigeration system have been preset for operation by the factory. No additional adjustments are necessary once the case is installed.

To protect the compressor from damage, the condensing unit is supplied with a low-pressure safety cut out and a high-pressure safety cut out. The low-pressure cut out is self-resetting and has a non-adjustable setting of 5 PSIG. The high-pressure cut out is manually reset (see service section), and has a non-adjustable setting of 410 PSIG.

High Pressure Cut-Out

On the OMC and OMC-LB, the high pressure cut-out is located adjacent to the condenser coil, behind the lower front air grill. To access the control, remove the lower front air grill by lifting up and away from the cabinet. To reset, press the red button on the control. The high-pressure control is set at 410 PSIG located in the discharge line. On the OMCSL48, the control is located on the side of the electrical box on top of the cabinet behind the light box. This is accessible from the top of the cabinet.

Temperature Control

A microprocessor controller is mounted behind the lower front air grill and is accessed by removing the air grill on the OMC-LB, 36, 48 and 72. The controller for the OMCSL48 is located on the electrical box behind the light box, accessible over the top of the cabinet.

This controller has many functions including a temperature control and a defrost control. It has been factory set for your application and has different factory settings for various product applications.

If you want to change the case operating temperature, a qualified refrigeration technician will be able to change the set points. There are different operating temperatures depending on which product is to be displayed in the case. There are three general product operating temperature options offered in **Figure 1**. The descriptions include; Meat, General Purpose (Factory Setting), and Fresh Cuts. **Figure 1** also includes all the preprogrammed parameters of the twin probe temperature control. **Figure 2** provides instructions for changing these and

other parameters in the case. **Figure 3** lists descriptions of the main alarm signals.

Thermometer

The thermometer is mounted at the left-hand lower front of the case. This allows the customer and operator to read refrigerated air temperature. Allow a minimum run time of 1 hour to achieve accurate temperature readings.

Electrical

Figures 4-8 show typical wiring diagrams. The light switch for the sign of the OMC and OMCSL48 cases is on top of the unit. The light switch for the OMC-LB case is located on the bottom of the light box.

Defrost

The OMC case has an automatic defrost control, which has been factory set. The defrost cycle is every 4 hours and terminates on temperature. The case uses off cycle air defrost. The compressor is turned off and the evaporator fans continue to run to melt frost from the coil. The condenser fans (1 fan on OMC-LB and 72) run during defrost except the OMCSL48 condenser fan, which does not run during defrost.

USER INFORMATION

Cleaning

The condenser fins on the OMC, OMC-LB and OMCSL48 cases must be cleaned a minimum of every 3 months.

Remove the lower front air grill by lifting up and away from the cabinet. Remove dust and lint using a brush or vacuum cleaner. Replace grill. On the OMCSL48, the face of the condenser is behind the light box, accessible over the top of the cabinet, which makes it always available for routine cleaning. No disassembly is required for this unit.

FAILURE TO OBSERVE THIS MAINTENANCE PROCEDURE COULD CAUSE A SIGNIFICANT DECREASE IN REFRIGERATION PERFORMANCE, COMPRESSOR DAMAGE AND INCREASED RUNNING COSTS.

To allow the refrigeration system to operate efficiently, the OMC and OMC-LB cabinets should be positioned with a minimum of 3-1/2" clearance from the rear wall. The wall bumper stops supplied for the rear of these units must always be attached to maintain this spacing. The OMCSL48 does not require a wall bumper for proper performance.

The cooler should be thoroughly cleaned before start-up and routinely thereafter to maintain a clean appearance. Use mild detergent (NEVER AN ABRASIVE CLEANER) and warm water to wipe out the inside of the cooler. Clean all glass with glass cleaner. The cooler will remain bright and sparkling with just a few minutes of cleaning each week. The case drain should be regularly cleared of debris and price tags.

NOTE: Do not use high-pressure water or steam to clean the interior.

Shelving

All OMC units have adjustable height shelves, which can be mounted horizontally or angled downward at front. When replacing shelves, ensure that the rear of the shelf is locked into the recess in the shelf bracket.

Loading

When loading the display case, the following points must be taken into consideration:

- Do not exceed the load limit as marked on the case.
- When restarting the display case after a prolonged shut down, the case should be left to operate empty for at least one hour before loading with pre-cooled product.

- Leave space between the stock to allow the refrigerated air to circulate.
- The air inlet at the lower front of the case and back wall or front grill discharge should never be obstructed.
- Product with a temperature higher than the display case should not be introduced.

SERVICE

Expansion Valve

All OMC cases have an evaporator coil located below the bottom coil cover. The OMC and OMCSL cases also have an evaporator coil located behind the perforated rear wall. Each coil has its own expansion valve set for 15-20°F superheat. Bottom TXV superheat should be lower than top superheat.

Lamps

The lamps are located behind the sign. Before servicing the lamps, turn off the lamp switch. The lamps in the OMC-LB and OMC cases are accessed by removing the screws on the top of the case and rotating the sign forward. Rotate the sign slowly to expose the lights. The lamps on the OMCSL48 can be serviced by removing the retaining bracket at the top front of the light box and sliding the sign up and out of the box channel.

Alarms

Figure 3 describes the main alarm signals.

Table 1

OMC-LB: 115V-1 PHASE-60Hz, 20A Straight 3-blade electrical receptacle
OMC-36: 115V-1 PHASE-60Hz, 30A Straight 3-blade electrical receptacle
OMC-48: 115V-1 PHASE-60Hz, 30A Straight 3-blade electrical receptacle
OMC-72: 208/230V – 115V -1 PHASE-60Hz, 30A NEMA L-14-30 twist lock electrical receptacle
OMCSL48: 115V-1 PHASE-60Hz, 30A Straight 3-blade electrical receptacle

FIGURE 1

SUMMARY OF PARAMETERS - (TWIN PROBE)

PROBE PARAMETERS		TYPE	MIN	MAX	UNIT	DEF	LB	36	48	72	SL48
11	Type of probe (0=NCT, 1= PTC) DO NOT CHANGE	C	0	1	-	0	0	0	0	0	0
rC	Calibration	F	-4	77	C/F	0	0	0	0	0	0
r2	Measurement stability	C	1	15	-	4	4	4	4	4	4
r3	Probe reading speed	C	1	15	-	8	8	8	8	8	8
r4	Virtual probe	C	0	100	-	0	0	0	0	0	0
r5	C/F (0=C, 1= F)	C	0	1	flag	0	1	1	1	1	1
r6	Decimal point (0=yes, 1=no)	C	0	1	flag	0	0	0	0	0	0
CONTROL PARAMETERS		TYPE	MIN	MAX	UNITS	DEF	LB	36	48	72	SL48
rd	Control differential	F	0.1	19.9	C/F	2					
	-Meat		-	-	-	-		6.8	6.8	6.8	6.8
	-General Purpose (Factory Setting)		-	-	-	-	6.8	6.8	6.8	6.8	6.8
	-Fresh Cuts		-	-	-	-	4.8	5.8	4.8	5.8	5.8
r1	Minimum set point allowed	C	-40	r2	C/F	-40	24	24	24	24	24
r2	maximum set point allowed	C	r1	*19	C/F	90	32	32	32	32	32
r3	Enable defrost end on time alarm(Ed)	C	0	1	flag	0	1	1	1	1	1
r4	Value to increase set point by, when A4 (digital input)=7	C	0	20	C/F	3	0	0	0	0	0
r5	Enable min and max temperature logging (0= no, 1=yes)	C	0	1	flag	0	1	1	1	1	1
rt	Interval of min and max temperature logging	F	0	199	hours	-	-	-	-	-	-
rH	Max temperature monitored during period rt	F	-50	90	C/F	-	-	-	-	-	-
rL	Minimum temperature monitored during period rt	F	-50	90	C/F	-	-	-	-	-	-
COMPRESSOR PARAMETERS		TYPE	MIN	MAX	UNITS	DEF	LB	36	48	72	SL48
c0	Compressor start-up delay after power up	C	0	15	min	0	2	2	2	2	2
c1	Minimum interval between two compressor starts	C	0	15	min	0	5	5	5	5	5
c2	Minimum compressor off-time	C	0	15	min	0	2	2	2	2	2
c3	Minimum compressor on time	C	0	15	min	0	2	2	2	2	2
c4	Duty setting (compressor safety, 0=OFF, 100= ON)	C	0	100	min	0	5	5	5	5	5
cc	Duration of continuous cycle	C	0	15	hrs	4	0	0	0	0	0
c6	Alarm cut-off delay after continuous cycle	C	0	15	hrs	2	2	2	2	2	2
DEFROST PARAMETERS		TYPE	MIN	MAX	UNITS	DEF	LB	36	48	72	SL48
do	Defrost (0=electric, 1= hot gas, 2=water/electric by time, 3=hot gas by time)	C	0	3	flag	0	0	0	0	0	0
dI	Interval between defrosts	F	0	199	hrs	8	4	4	4	4	4
dt	Defrost termination temperature	F	-40	-199	C/F	4	43	43	43	43	43
dP	Max duration of defrost (time protection) if Dc =0; or defrost time=2.3	F	1	199	min	30	60	60	60	60	60
d4	Defrost on power up (0=no, 1=yes)	C	0	1	flag	0	0	0	0	0	0
d5	Defrost delay after unit power up of multifunction input	C	0	199	min	0	180	180	180	180	180
d6	Display override during defrost (0=no, 1=yes)	C	0	1	flag	0	0	0	0	0	0
dd	Dripping (drain) time	F	0	15	min	2	0	0	0	0	0
d8	Duration of alarm cut-out after defrost and/or opening of door	F	0	15	hrs	1	2	2	2	2	2
d9	Defrost has priority over compressor protection (0=no, 1=yes)	C	0	1	flag	0	0	0	0	0	0
dr	Defrost probe reading	F	0	-	C/F	-	-	-	-	-	-
dC	Time basis (0=hours/minutes 1= minutes/seconds)	C	0	1	flag	0	0	0	0	0	0
ALARM PARAMETERS		TYPE	MIN	MAX	UNIT	DEF	LB	36	48	72	SL48
A0	Alarm and fan differential	C	0.1	20	C/F	0.2	0.4	0.4	0.4	0.4	0.4
AL	Low temperature alarm (deviation from set point)	F	0	199	C/F	10	4	4	4	4	4
AH	High temperature alarm (deviation from set point)	F	0	199	C/F	10	36	36	36	36	36
Ad	Temperature alarm delay	C	0	199	min	120	120	120	120	120	120
A4	Multifunction input configuration IR32S, Y and C IR32M	C	0	7	-	0	1	1	1	1	1
A5	(must be kept at 0)		0	5	-	0	0	0	0	0	0
A6	Duty setting for external alarm (0= OFF,100= ON)	C	0	100	min	0	0	0	0	0	0
A7	External alarm delay 9A4=2, Multifunction input	C	0	199	min	0	0	0	0	0	0
FAN PARAMETERS		TYPE	MIN	MAX	UNIT	DEF	LB	36	48	72	SL48
F0	(difference between ambient and evap temp.,2= Fan regulator evap temp)	C	0	2	flag	0	0	0	0	0	0
F1	Fan turn-off temperature if F0=1: fans are on when evap temp< (ambient temp-F1-A0) if F0=2 Fans are on if evap temp<(set point+F1-A0)	F	0	20	C/F	5	0	0	0	0	0
F2	Cycle fans with compressor (0=no, 1= yes)	C	0	1	flag	1	0	0	0	0	0
F3	Stop fans during defrost (0=no, 1= yes)	C	0	1	flag	1	0	0	0	0	0
Fd	fan delay (After dripping)	F	0	15	min	3	0	0	0	0	0
OTHER SETTINGS		TYPE	MIN	MAX	UNIT	DEF	LB	36	48	72	SL48
Ho	Address within network	C	0	15	-	0	0	0	0	0	0
H1	Multifunction output (0=Auxiliary, 1=Alarm n.c., 2=Alarm n.o.)	C	0	1	flag	1	0	0	0	1	0
H2	Access locking (Keypad and IR remote)	C	0	3	-	3	1	1	1	1	1
H3	code to permit remote programing	C	0	199	-	0	0	0	0	0	0
FACTORY SET POINT (GENERAL PRODUCT)		TYPE	MIN	MAX	UNIT	DEF	LB	36	48	72	SL48
	-Meat		-	-	-	-		27	27	27	27
	-General Purpose (Factory Setting)		-	-	-	-	27	27	27	27	27
	-Fresh Cuts		-	-	-	-		29	27	29	27

FIGURE 2

Temperature Control

For general introduction please see Page 2. The following is a description of the keys on the temperature control display.

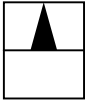

Up Key:

- Increases the displayed value when setting set-point and parameters.
- Goes through the parameter.
- *If pressed for more than 5 seconds together with the down key (*): enables/inhibits the continuous cycle.*



Down Key:

- Decreases the displayed value when setting set-point and parameters.
- Goes through the previous parameter
- *If pressed for more than 5 seconds: forces a defrost cycle (only if H1=0).*
- *If pressed for more than 5 seconds together with the up key(*): enables/inhibits the continuous cycle.*

(*) **NOTE:** first push DOWN key, then UP key



SEL Key:

- Selects the set-point (see SET-POINT section)
- Indicates the parameter value (see PARAMETERS SELECTION).
- *If pressed for more than 5 seconds together with the prg key: enters the configuration menu (see PARAMETERS SELECTION - second level).*



PRG Key:

- Stops the buzzer.
- *If pressed when the control starts: resets the default parameters (see ALARMS AND SIGNALS).*
- *If pressed for more than 5 seconds: enters the frequent parameters menu (see below).*

- *If pressed for more than 5 seconds together with the sel key: enters the configuration menu (see PARAMETERS SELECTION - second level).*

Indications On The Display

COMP	1 LED to indicate compressor ON 2 LED's to indicate Continuous Cycle ON (**).
DEF	defrost ON (H1=1); if H1=0, the LED is on to indicate "REVERSE" working mode.

If one or more LED's blink: see the ALARMS AND SIGNALS section.

(**) Not present in the controllers with serial number lower than 10.000.

Functioning: during normal working conditions, the display shows the value measured by the regulation probe. In case of active alarm, the relative code blinks alternately with the alarm code.

The following information shows how to change the set point and differential on your case in the event that there is a change in the product displayed.

Set-Point:

- Press the SEL key for one second to display the set-point value;
- After two seconds, the set value blinks;
- Press UP or DOWN to increase or decrease the value;
- Press the SEL key to confirm the new value.

Control Differential:

- Follow the Parameters Modification procedure. Find the "rd" parameter on the display by pressing UP or DOWN until it appears on the display.
- Press SEL to display the Control Differential parameter value.
- Press UP or Down to increase or decrease the value.
- Press SEL to confirm temporarily the new value and display its code.

- Press PRG to confirm the new value and exit the parameter modification procedure.

The following are parameter setting procedures and general information.

Parameters:

The parameters have been divided into two sections: frequent parameters and configuration parameters:

FIRST SECTION: frequent parameters (type=F in the table); no password is required to enter.

- Press the PRG key for more than 5 seconds (in case of alarm, silence the buzzer first);
- The first modifiable parameter code is displayed.

To modify parameters see PARAMETERS MODIFICATION on the following page:

SECOND SECTION: configuration parameters (type=C in the table): a password is required to enter.

- Press PRG and SEL simultaneously for more than 5 seconds;
- OO is displayed.
- Press UP and DOWN until 22 is displayed; (password).
- Press SEL to confirm;
- The first modifiable parameter code is displayed.

To modify the parameters see PARAMETERS MODIFICATION below.

Parameters Modification:

- Press UP or DOWN to show the code of the parameter that has to be changed;
- Press SEL to display the selected parameter value;
- Press UP or DOWN to increase or decrease the value.
- Press SEL to confirm temporarily the new value and display its code, Repeat the procedure from the beginning. Press UP or DOWN.

To exit modifying the parameters with the new values:

- Press PRG to confirm the new values and exit the parameters modification procedure.

To exit without modifying any parameter: Do not press any key for at least 60 seconds (TIME OUT).

Defrost:

- Press the DEF key for more than 5 seconds to force a defrost cycle.

Buzzer Off:

- Press the PRG (MUTE) key to silence the buzzer. The alarm code remains until the alarm condition is eliminated.

Continuous Cycle:

- Press UP and DOWN simultaneously for 5 seconds to enable/inhibit the compressor's continuous cycle. (see CC & oS parameters in the PARAMETERS TABLE).

FIGURE 3

Description of the Main Alarm Signals

The following is a list of the flashing alphanumeric signals that may occur on your temperature controller and the appropriate troubleshooting options.

FLASHING LED

Initiation of the relative function is delayed for a period while awaiting an external consent or while held up by another process still in progress. For example, if a defrost is requested during continuous cycle operation, the defrost will be held up until the continuous cycle is complete, and the appropriate LED (Def) will flash.

E0 FLASHING: control probe error

- Probe not working because the signal has been interrupted or there is a short-circuit.
- Probe not compatible with the equipment.
- Parameter /0 does not correspond to unit's hardware set-up.

E1 FLASHING: evaporator probe error – (found in program mode only)

- Probe not working because the signal interrupted or there is a short circuit.
- Probe not compatible with the equipment.
- Parameter /0 does not correspond to unit's hardware set-up.

AI FLASHING: immediate Multi-function digital input

- Suction problem high or low pressure safety open.
- Check Multi-function input and parameter A4.

Ad FLASHING: delayed Multi-function digital input.

- Check Multi-function input and parameters A4 and A7.

L0 FLASHING: low temperature alarm

- The probe has registered a temperature further below the set value than the value given to parameter AL.
- Check parameters AL, Ad and A0.
- The alarm will cease as soon as the temperature returns within the limits selected (see parameter AL).

HI FLASHING: high temperature alarm

- The probe has registered a temperature further above the set value than the value given to parameter AH.

FIGURE 4 - (OMC-LB)

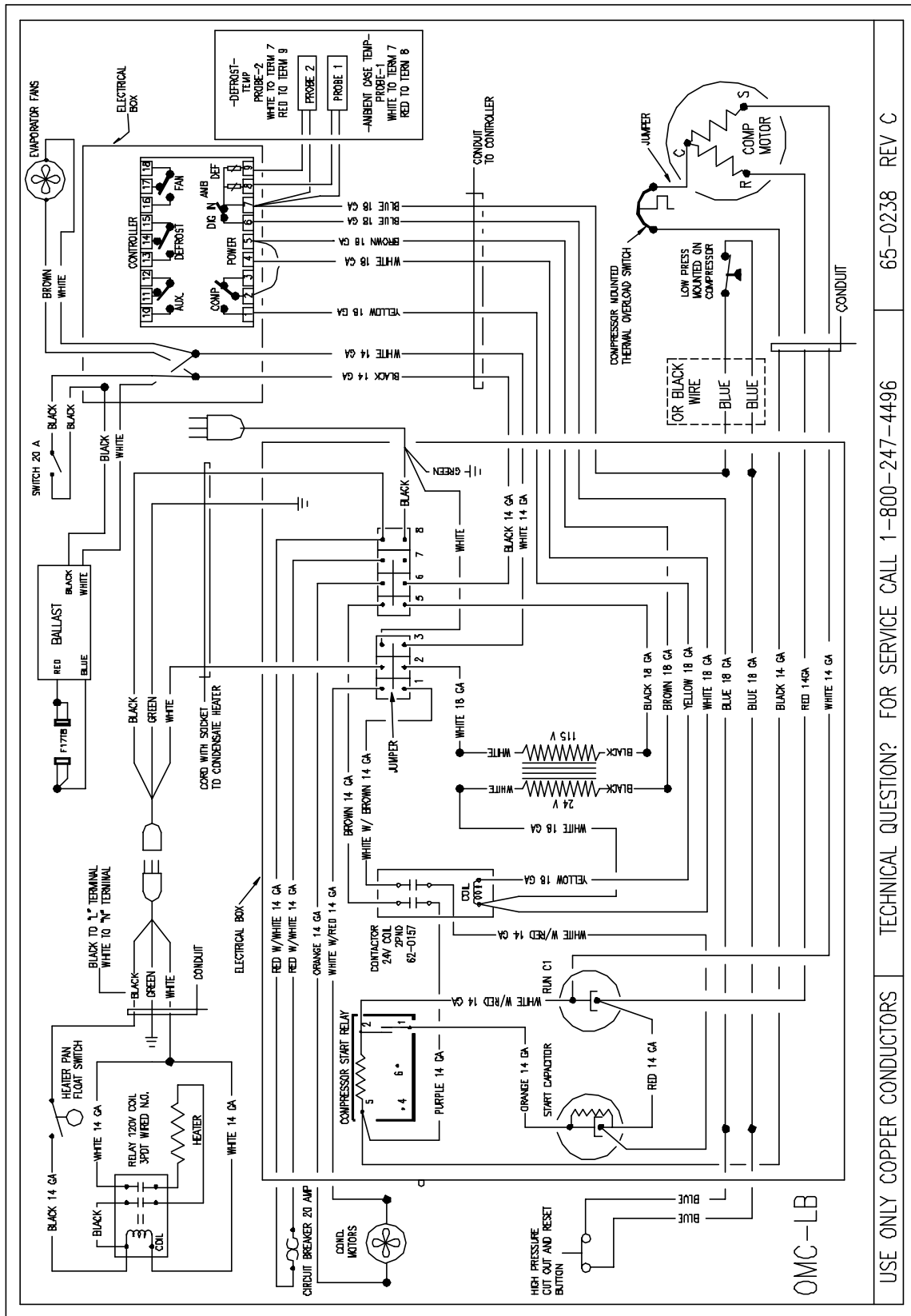

USE ONLY COPPER CONDUCTORS TECHNICAL QUESTION? FOR SERVICE CALL 1-800-247-4496 65-0238 REV C

FIGURE 5 – (OMC-36 & OMC-48)

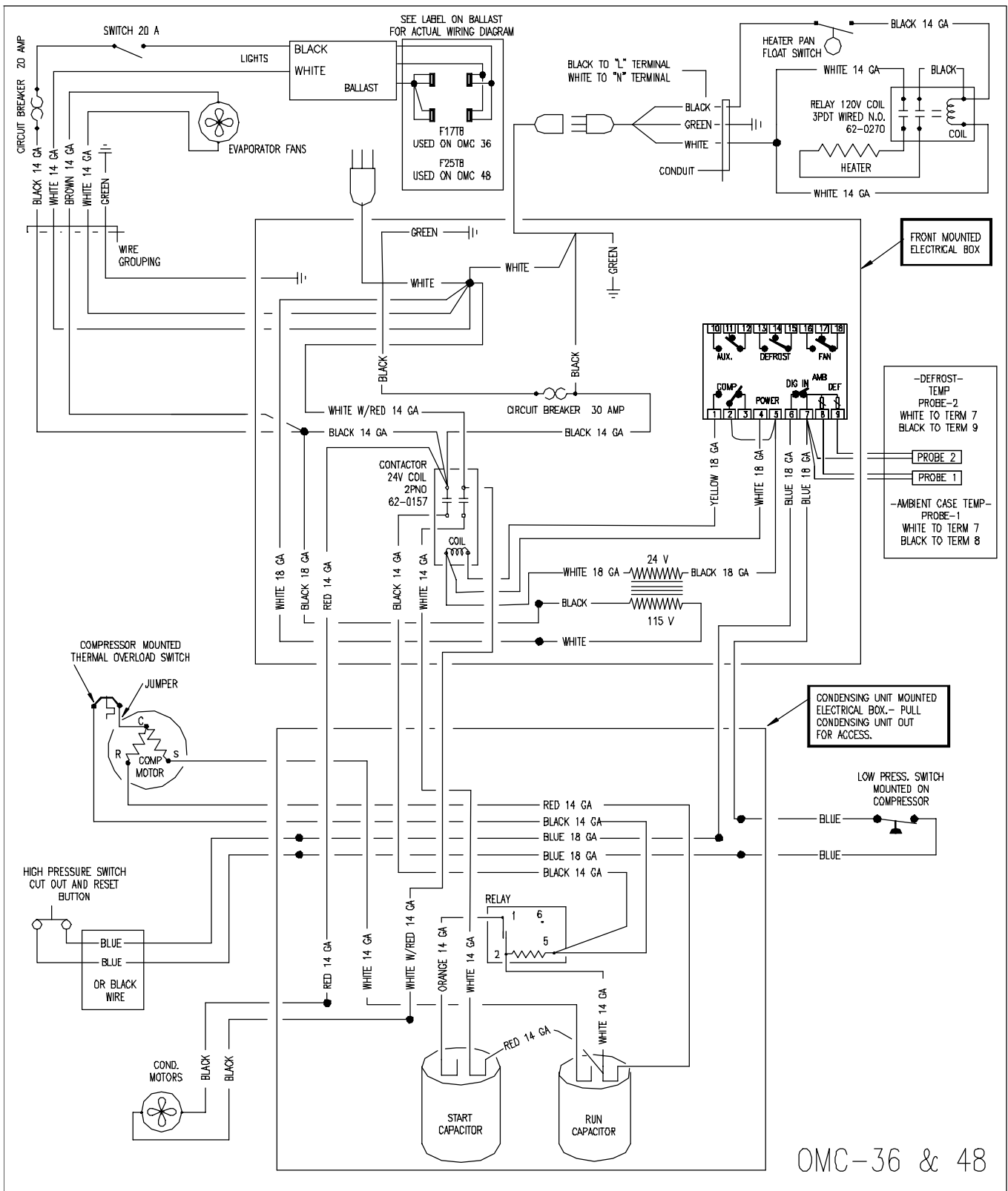

USE ONLY COPPER CONDUCTORS

TECHNICAL QUESTION? FOR SERVICE CALL 1-800-247-4496

65-0236 REV D

FIGURE 6 - (OMC-72)

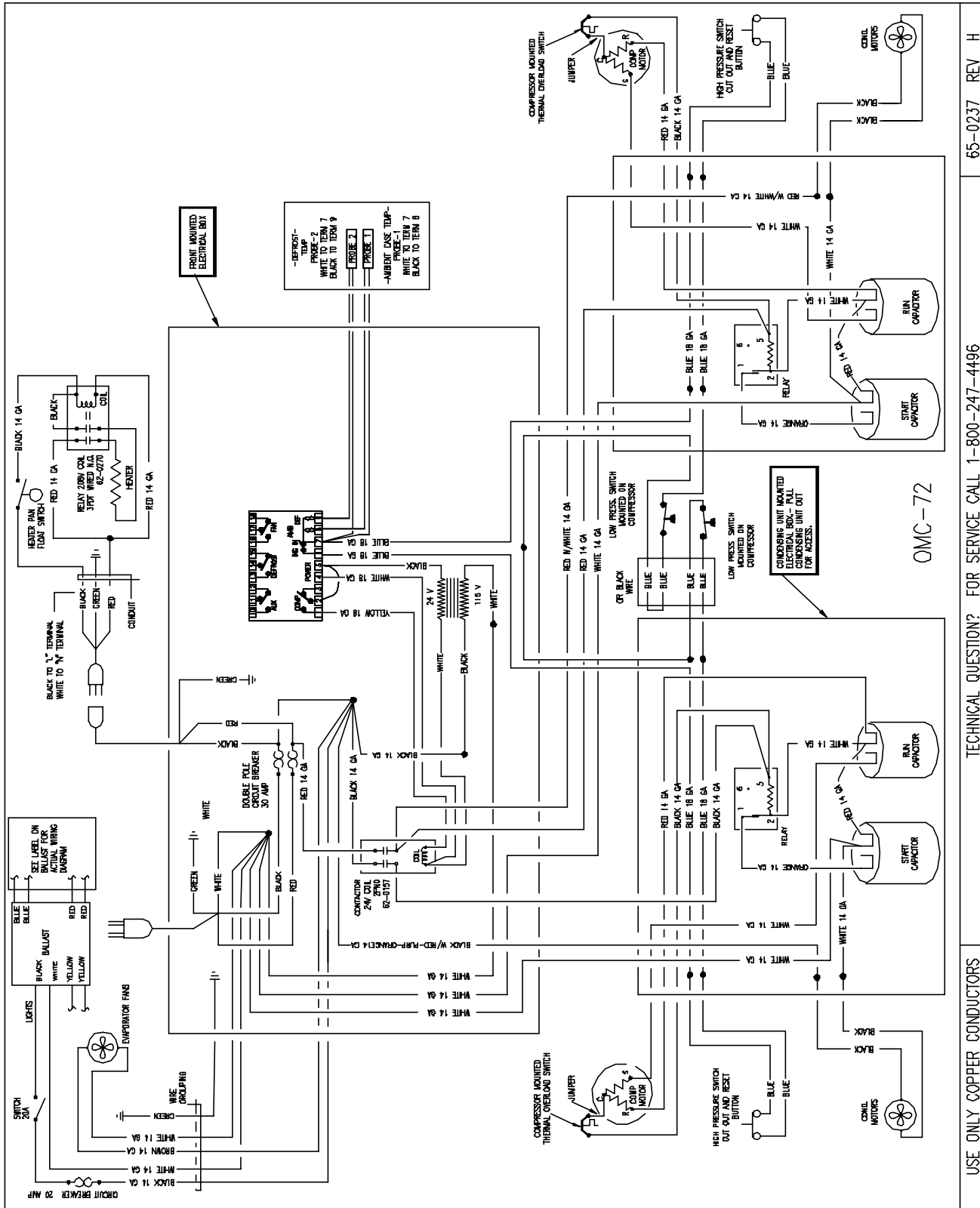

65-0237 REV H

TECHNICAL QUESTION? FOR SERVICE CALL 1-800-247-4496

USE ONLY COPPER CONDUCTORS

FIGURE 7 - (OMCSL48)

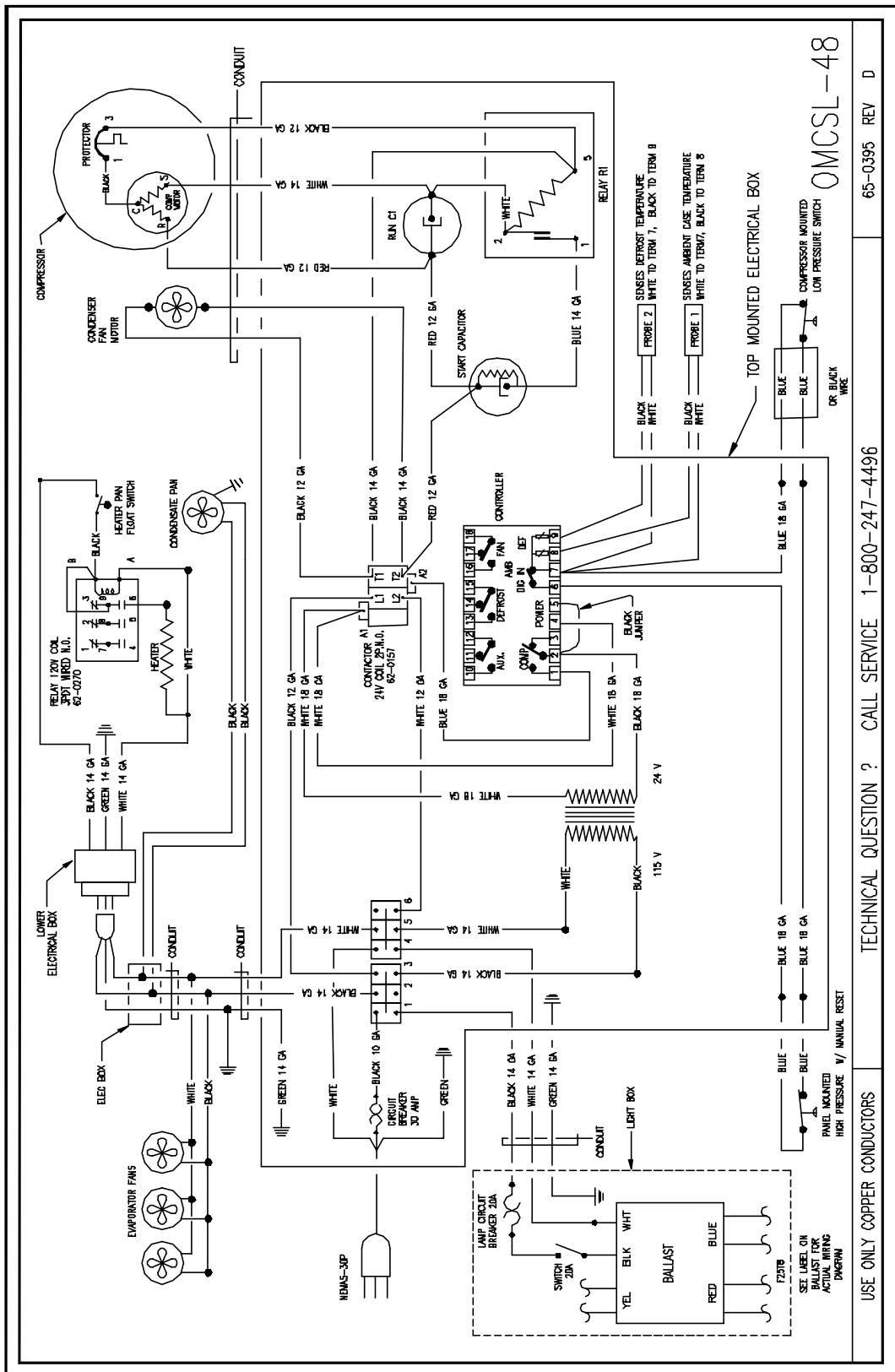

OMCSL-48

USE ONLY COPPER CONDUCTORS TECHNICAL QUESTION ? CALL SERVICE 1-800-247-4496 65-0395 REV D

OMC-LB SPECIFICATION SHEET

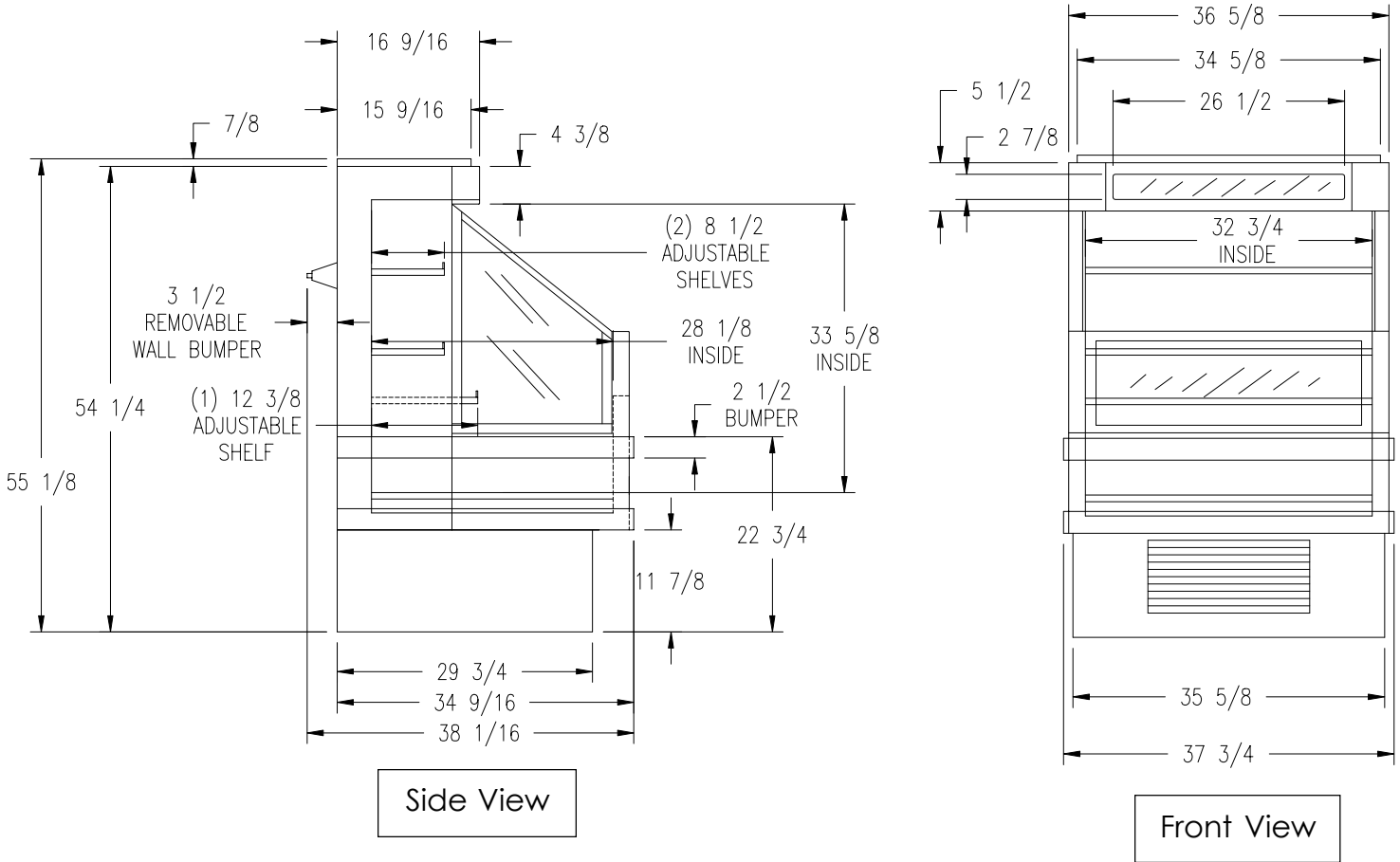

MODEL	WEIGHT (w/shelves)	OUTSIDE DIMENSIONS (INCHES)			INSIDE DIMENSIONS (INCHES)			CUBIC FEET CAPACITY
		W	H	D	W	H	D	
OMC-LB	310	37 3/4	55 1/8	38 1/16	32 3/4	33 5/8	28 1/8	18

MODEL	ELECTRICAL			H.P.	REF.	
	INCOMING SUPPLY		MIN CIRCUIT AMPS			AMPS RLA
OMC-LB	115-1 PHASE-60 HZ.		20	16	3/4	R404A

CASE DESIGNED TO OPERATE IN AN AMBIENT AIR TEMPERATURE OF 75°F OR LOWER AND RELATIVE HUMIDITY OF 55% OR LOWER



All specifications are subject to change without notice.

OMC SPECIFICATION SHEET

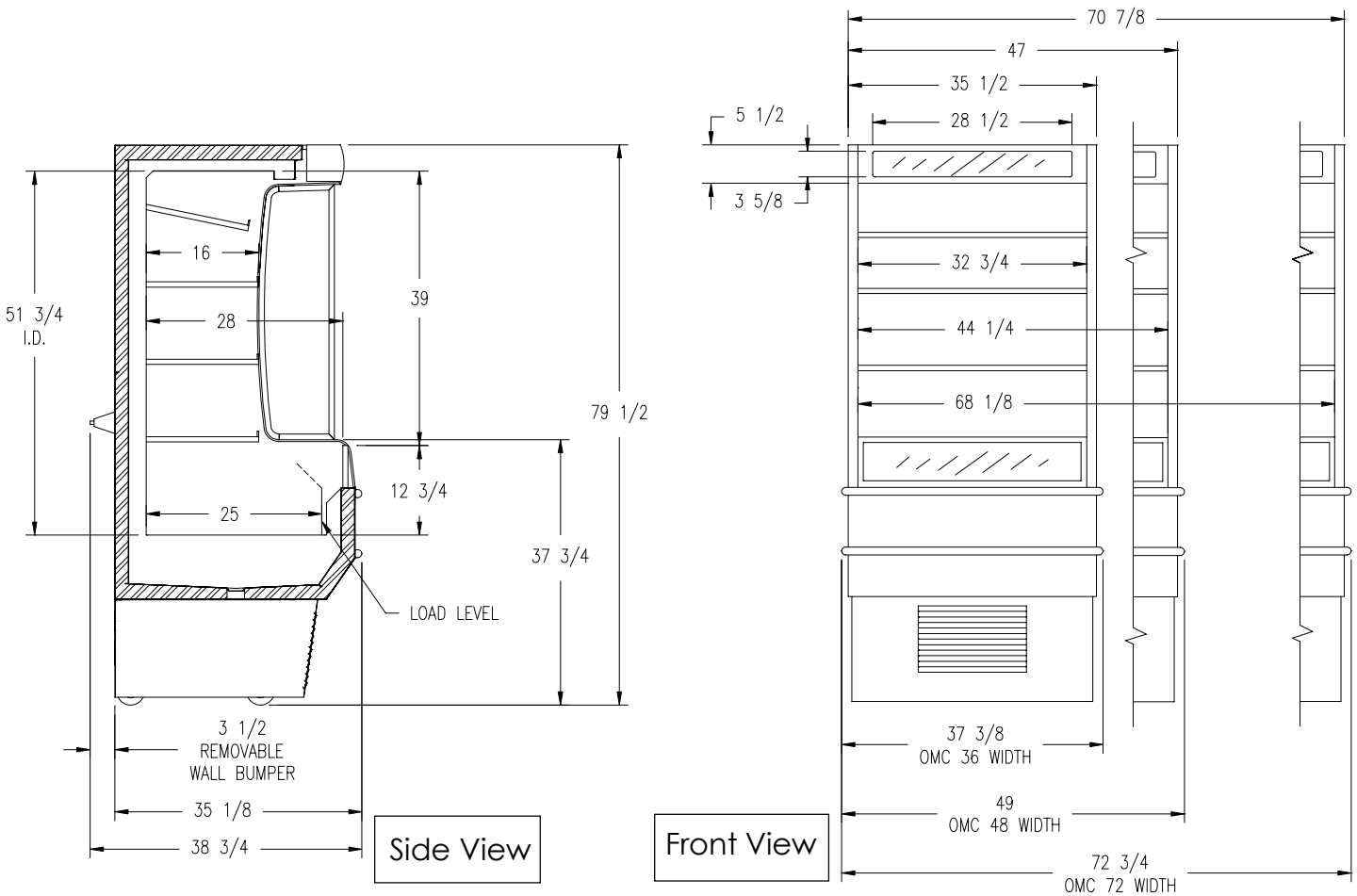

MODEL	WEIGHT (w/shelves)	OUTSIDE DIMENSIONS (INCHES)			INSIDE DIMENSIONS (INCHES)			CUBIC FEET CAPACITY
		W	H	D	W	H	D	
OMC 36	547	37 3/8	79 1/2	38 3/4	32 3/4	51 3/4	25	18
OMC 48	657	49	79 1/2	38 3/4	44 1/4	51 3/4	25	24
OMC 72	740	72 3/4	79 1/2	38 3/4	68 1/8	51 3/4	25	37

MODEL	ELECTRICAL			H.P.	REFRIG.
	INCOMING SUPPLY	MIN CIRCUIT AMPS	AMPS RLA		
OMC 36	115-1 PHASE - 60 HZ	30	19.6	3/4	R-404A
OMC 48	115-1 PHASE - 60 HZ	30	21.6	1	R-404A
OMC 72	208/230 - 115 - 1 PHASE - 60 HZ	30	19.0	(2) 3/4	R-404A

CASE DESIGNED TO OPERATE IN AN AMBIENT OF 75°F OR LOWER
AND RELATIVE HUMIDITY OF 55% OR LOWER



All specifications are subject to change without notice.

OMC-LB, OMC-36, OMC-48, OMC-72, OMCSL48
03035

OMCSL48 SPECIFICATION SHEET

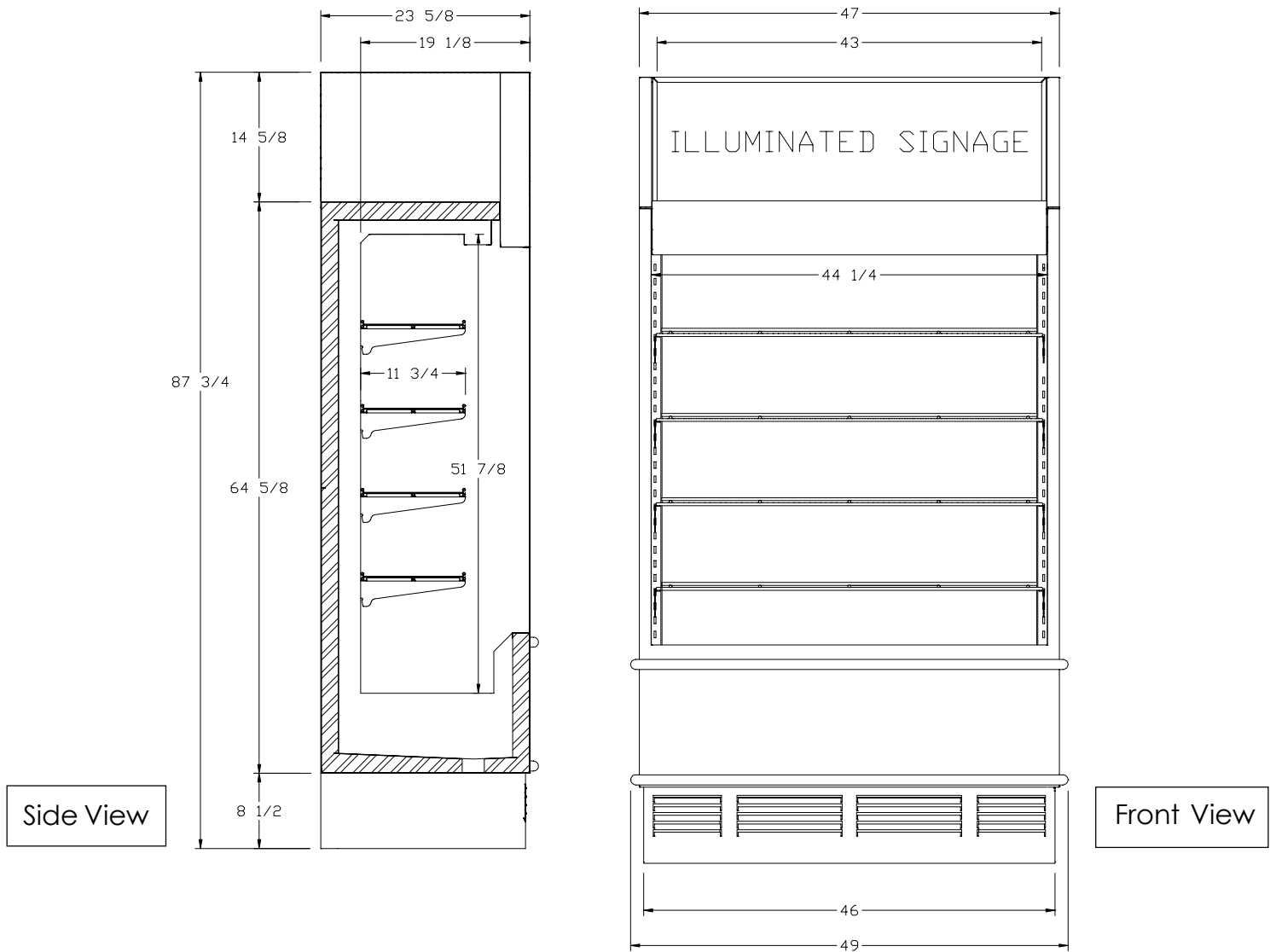

MODEL	WEIGHT w/shelves (pounds)	OUTSIDE DIMENSIONS (INCHES)			INSIDE DIMENSIONS (INCHES)			CUBIC FEET CAPACITY
		W	H	D	W	H	D	
OMCSL48	585	47	87 3/4	23 5/8	44 1/4	51 7/8	19 1/8	15.6
MODEL	ELECTRICAL				H.P.	REF.		
	INCOMING SUPPLY			MIN CIRCUIT AMPS			AMPS RLA	
OMCSL48	115-1 PHASE-60 HZ.			30	24	1 1/2	R404A	

CASE DESIGNED TO OPERATE IN AN AMBIENT AIR TEMPERATURE OF 75°F OR LOWER AND RELATIVE HUMIDITY OF 55% OR LOWER



All specifications are subject to change without notice.

1. **Limited Warranty.** ZERO ZONE, INC. ("Seller") hereby warrants that any products manufactured by it and sold under this Warranty shall be free for a period of one year from the date of shipment, from defects in material and workmanship which, under normal use and service would render such products unusable or unserviceable. The obligation of Seller under this Warranty shall be limited to the repair or replacement of any parts that the Seller determines are defective. This Limited Warranty does not cover labor, freight, transportation or other charges incidental to replacement or repair. Parts returned to Seller must be returned freight prepaid and replacement parts will be returned to the Buyer freight collect.

2. **Motor Compressor Extended Warranty.** Seller hereby warrants with respect to any motor compressor sold under this extended Warranty, exclusive of any and all parts of the condensing unit assembly thereof, that such motor compressor shall be free from defects in material and workmanship for a period of four (4) years from the date of the expiration of the one year Warranty provided by the manufacturer of such motor compressor, **if the Buyer purchases said Warranty at the time of equipment purchase.** In the event the motor compressor is not free from defects in material and/or workmanship during such four-year period, Buyer must purchase a replacement for the defective motor compressor and obtain whatever salvage credit may be available from the manufacturer thereof. Upon receipt by Seller or written notice from Buyer of compressor. Seller will issue a purchase credit or a refund, at Seller's option, for the difference between the compressor replacement cost and the salvage credit. All labor and shipping charges incurred in connection with such replacement shall be the sole obligation of the Buyer.

3. **Product Not Manufactured by Seller.** The written Warranty, if any, provided by the manufacturer of any part of the refrigeration unit sold by Seller to Buyer, but not manufactured by Seller, is hereby assigned to Buyer. However, Seller makes no representation or Warranty regarding the existence, validity or enforceability of any such written Warranty.

4. **LIMITATION AND EXCLUSION OF WARRANTIES.** THE WARRANTIES SET FORTH HEREIN ARE EXCLUSIVE AND IN LIEU OF ALL OTHER WARRANTIES AND REMEDIES WHATSOEVER, INCLUDING BUT NOT LIMITED TO, IMPLIED WARRANTIES OF MERCHANTABILITY AND/OR FITNESS FOR A PARTICULAR PURPOSE.

5. **Consequential Damages.** Notwithstanding anything to the contrary set forth in this Warranty Certificate, Seller shall not be liable for any incidental or consequential damages arising out of, or directly or indirectly caused by a defective part sold by Seller, including but not limited to, costs arising from the replacement of the part, loss of gas, loss of product, or any damage to person or property, whether as a result of Seller's negligence, breach of contract, breach of Warranty or otherwise.

Model No. _____ Serial No. _____