



ZERO ZONE

MEDIUM AND LOW TEMPERATURE DISPLAY CASES

INSTALLATION & OPERATION MANUAL



CASE CLOSED

TABLE OF CONTENTS

ZERO ZONE WARRANTY	1
INTRODUCTION	2
■ Important User Information	2
■ Manufacturer	2
■ Intended Use	2
■ Display Case Models	2
■ Delivery Inspection	3
■ Packaging	3
■ Location	4
INSTALLATION	5
■ Leveling	5
MOVING CASES	10
LINEUP ASSEMBLY	12
DRAIN LINE	16
BUMPER AND KICKPLATE	17
■ Installing End Kickplate	17
■ Installing Bumper	17
■ Under Case Return Air Flow Assembly Instructions	19
GENERAL INFORMATION	20
■ Cleaning	20
■ Shelf Location	20
■ Shelves	20
■ Loading the Case	20
■ Light Switch	21
■ Case Thermometer	21
■ Service	21
REFRIGERATION	23
■ General	23
■ Low Temp	26
■ Medium Temp	28
ELECTRICAL	29
■ General	29
■ Low Temp	32
■ Medium Temp	36
DEFROSTING	39
■ Low Temp	39
■ Low Temp/Medium Temp	43
■ Medium Temp	44

ZERO ZONE WARRANTY

LIMITED WARRANTY

Zero Zone, Inc. (Seller) hereby warrants that any products manufactured by it and sold are warranted to be free from defects in material and workmanship, under normal use and service for its intended purpose, for a period of one (1) year from the date of original installation (not to exceed 15 months from the date of factory shipment). The obligation under this warranty shall be limited to repairing or exchanging any part, or parts, without charge, FOB Factory, and which is proven to the satisfaction of Zero Zone's service department to be defective. Zero Zone reserves the right to inspect the job site, installation, and reason for failure. This limited warranty does not cover labor, freight, or loss of food or product, including refrigerant loss. This warranty does not apply to motors, switches, controls, lamps, driers, fuses or other parts manufactured by others and purchased by the seller unless the manufacturer of these items warrants the same to the seller and then only to the extent of such manufacturer's warranty to the seller. Any products sold on an "AS IS" basis shall not be covered by this warranty.

EXTENDED WARRANTIES

In addition to the standard limited warranty, for further consideration, the Company will extend to the original purchaser, a limited extended warranty on the compressor only, following expiration of the standard warranty. The seller agrees to repair or exchange, at its option, or provide reimbursement for such exchange as directed, less any credit allowed for return of the original compressor, of a compressor of like or similar design and capacity, if it is shown to the satisfaction of Zero Zone that the compressor is inoperative due to defects in factory workmanship or material under normal use and services as outlined by Zero Zone in its "Service and Installation" instructions.

LENGTH OF EXTENDED WARRANTY

Any compressor warranty may be extended for an additional four (4) years but such extension must be purchased prior to shipment to be effective. In those instances on manufactured systems where factory installed "Zero Zone Oil Management Systems" are purchased the original limited warranty shall be extended automatically to two (2) years total and purchased extended warranties shall be extended automatically for a total of six (6) years from the date of factory shipment. This warranty is only for the compressor and not for any other associated parts of the refrigeration system.

PRODUCT NOT MANUFACTURED BY THE SELLER

The written Warranty, if any, provided by the manufacturer of any part of the refrigeration unit sold by Seller to Buyer, but not manufactured by Seller, is hereby assigned to the Buyer. However, Seller makes no representation or Warranty regarding the existence, validity or enforceability of any such written Warranty.

LIMITATION AND EXCLUSION OF WARRANTIES

THE WARRANTIES SET FORTH HEREIN ARE EXCLUSIVE AND IN LIEU OF ALL OTHER WARRANTIES AND REMEDIES WHATSOEVER, INCLUDING, BUT NOT LIMITED TO, IMPLIED WARRANTIES OF MERCHANTABILITY AND/OR FITNESS FOR A PARTICULAR PURPOSE.

INTRODUCTION

IMPORTANT USER INFORMATION

Copyright © 2013 Zero Zone, Inc.

All rights reserved. No part of the contents of this manual may be reproduced, copied, or transmitted in any form or by any means including graphic, electronic, or mechanical methods or photocopying, recording, or information storage and retrieval systems without the written permission of the publisher, unless it is for the purchaser's personal use.

The information in this manual is subject to change without notice and does not represent a commitment on the part of Zero Zone. Zero Zone does not assume any responsibility for any errors that may appear in this manual. In no event will Zero Zone be liable for technical or editorial omissions made herein, nor for direct, indirect, special, incidental, or consequential damages resulting from the use or defect of this manual.

The information in this document is not intended to cover all possible conditions and situations that might occur. The end user must exercise caution and common sense when installing, using, or maintaining Zero Zone products. If any questions or problems arise, call Zero Zone at 800-247-4496.

Any change to a Zero Zone product made during the installation, startup, or at any other time must be submitted in writing to Zero Zone for approval and be approved by Zero Zone in writing prior to commission. The product warranty is voided when any unapproved change is made to a Zero Zone product.

MANUFACTURER

Zero Zone, Inc.
Display Case Division

110 N Oakridge Dr • North Prairie, WI 53153 • 800-247-4496 • www.zero-zone.com

INTENDED USE

Zero Zone products are intended to be installed and used as described in this manual and other related Zero Zone literature, specifications, drawings, and data. Always install Zero Zone products on a level surface.

The information contained in this manual pertains to Zero Zone Display Cases, which include the following:

DISPLAY CASE MODELS

LOW TEMPERATURE DISPLAY CASES	
RVZC30	RMZC24
RVZC30T2	3RMZC30WA
RVZC30BB	3RVZC30WAT2
RVZC30T2BB	

MEDIUM TEMPERATURE DISPLAY CASES	
RVCC30	RMCC24
RVCC30T2	3RMCC30WA
RVCC30BB	3RVCC30WAT2
RVCC30T2BB	

INTRODUCTION

DISPLAY CASE MODELS (CONT.)

Zero Zone produces high quality refrigerated display cases using state-of-the-art components. The cases are built with the thickest insulation in the industry and a high efficiency evaporator coil. Potential case features include:

- Brushless D.C. electronic motors, PSC*, or shaded pole fan motors*
- T-8 fluorescent lamps*
- LED lighting
- Standard-energy*, low-energy, or no-energy doors

These display cases were designed and tested using the following industry standards:

- ASHRAE Standard 72-2005 — Method of Testing Commercial Refrigerators and Freezers (ANSI Approved)
- AHRI 1200 — Performance Rating of Commercial Refrigerated Display Merchandisers and Storage Cabinets (ANSI Approved)
- UL 471- Commercial Refrigerators and Freezers (ANSI Approved) (equipment certified by ETL)
- NSF 7- Commercial Refrigerators and Freezers (ANSI Approved) (equipment certified by NSF)
- DOE Compliant (All U.S. Sales)

ASHRAE 72-2005 specifies the test conditions for the equipment. It includes the ambient conditions of 75°F dry bulb and 55% RH. It also specifies the door opening requirements for the performance test. Doors are opened 6 times in 1 hour for 6 seconds. The door opening test period is for 8 hours during one 24-hour performance test. As an example, a 5-door case will have 240 door openings during one 24-hour test. Consult the factory if your store exceeds these test conditions.

**Not for U.S. Sales*

DELIVERY INSPECTION

These display cases were carefully factory-tested, inspected and properly packed to ensure delivery in the best possible condition. The equipment should be uncrated and checked for damage immediately upon delivery. **DAMAGE MUST BE NOTED AT TIME OF DELIVERY AND ALL CLAIMS FOR DAMAGES MUST BE FILED WITH THE TRANSPORTATION COMPANY - NOT WITH ZERO ZONE.** The carrier will supply necessary report and claim forms.

PACKAGING

Each case in a lineup is labeled to identify the lineup and joint. The label uses a number and letter designation. The number indicates the lineup. The letter indicates the case joint. Case joints begin with the letter A at the left most joint in the lineup when looking at the front of the lineup. The joint for two cases has the same number-letter designation (**Figure 1 on page 4**). Back-to-Back cases have a unique designation. The left most joint in the lineup when looking at the front of the case is labeled 1-A. The joint on the back of the case is 1-A1 (**Figure 1 on page 4**).

Insulated dividers are factory installed to separate low and medium temperature cases. They are also used to join different case models. Factory installed plexiglass dividers separate refrigeration circuits.

The first case in the lineup (with the right side labeled "A") has a packet attached to the door handle that contains the manual, special instructions for installing ordered options, and touch-up paint if the cases are custom painted. Every case in the lineup has a packet attached to the door that contains the specific information for that case. The packing slip is taped to the right-hand door of each case.

Bumpers and kickplates are shipped on top of the case. Shelves for the case are tie-wrapped and blocked into the individual cases. Other accessories like drain traps, drain pans, condensate evaporation pans, and hat channels are shipped in the case that require the parts.

Materials for joining cases include caulk, joining bolts, splices, and T or J strips. These parts are supplied in cases that have a left-side insulated divider or no left end. The parts are bagged and taped to the coil covers. The T and J strips are tied to the shelves.

INTRODUCTION

LOCATION

These cases must not be installed in the direct rays of the sun or near a source of radiant heat.

Be certain that the floor under the installation is of sufficient strength to prevent sagging. Out of level conditions will result in reduced performance.

Wall cases (cases set with a back to a wall) and cases set back-to-back, should be positioned to allow a minimum 2-4" space behind the back of the unit(s). This will allow necessary air to circulate behind the display case(s). Higher humidity stores with minimal air circulation require a 4" gap.

Figure 1: Case Label Information

	2-B	2-B	2-A	2-A
	1-A	1-A	1-B	1-B

FRONT OF LINEUP

CASE JOINT LABELS

	1-A1	1-A1	1-B1	1-B1
	1-A	1-A	1-B	1-B

FRONT OF LINEUP

BACK TO BACK CASE JOINT LABELS

INSTALLATION

LEVELING

Cases must be installed perfectly level to allow efficient operation of the refrigeration coils and complete drainage of defrost water. Since a level area is seldom available, the following steps are recommended to insure a level installation.

1. Measure off and mark on floor the exact dimensions of the case lineup (**Figure 2A**). (Check blueprints).
2. Snap a chalk line at the locations for the front and back positions of the bases.
3. Mark locations of all joints (front and back).
4. Using a laser or transit, find the highest point along both base rail position lines. Using the high point as a reference, mark the difference directly on the floor to each joint, front and back (**Figure 2B**).
5. If you plan on using optional hat channels to raise the case height, place them under each pair of bases. The 3 and 4-door hat channels will be angled slightly to support the front and rear bases. (**Figure 3 on page 6** and **Figure 5 starting on page 7**).
6. Place the required number of shims under each base or optional hat channel at each joint (front and back) to equal the highest point.
7. The RVZC30, RMZC24, RVCC30 and RMCC24, 2 through 5-door cases, have segmented bases mounted at the ends and under the center section of the case. The RVZC30 and RVCC30 1-door and RVZC30BB and RVCC30BB have full bases that run front to back and are located at the ends and under the center sections of the case. The 3RMZC30WA and 3RMCC30WA have segmented bases that run front to back.
8. Tape all shims in place (**Figure 2C**). **Figure 4 on page 6** shows the correct orientation of shims under the base or channel.
9. Place additional support shims under all other bases or hat channels (**Figure 5 starting on page 7**).
10. Use a carpenter's level to check installation as you go. The case should be level from front to back and side to side. Install the case at the highest point first, if part of a lineup. Check the level on the face of the glass doors and sides of the mullions. Do not use the ceiling to check level.
11. If you've purchased seismic restraints, specific instructions for attaching those restraints are included in your document package. These instructions should be read and followed before the lineup is assembled.

Figure 2: Leveling Cases Prior to Joining

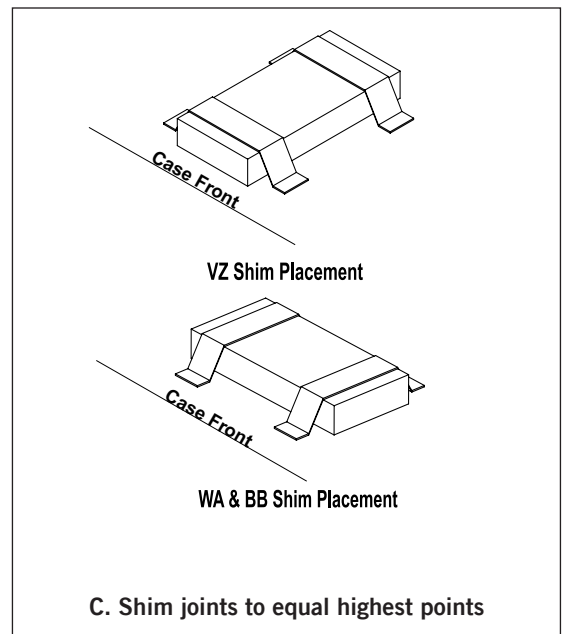
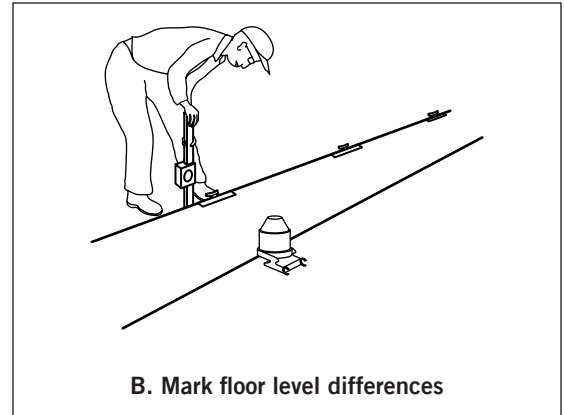
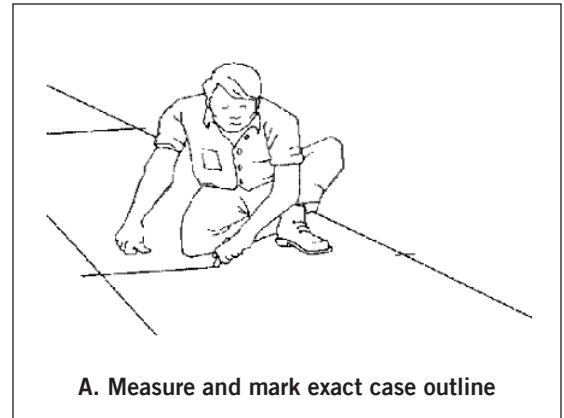

INSTALLATION

LEVELING (CONT.)

Figure 3: Typical Hat Channel Locations

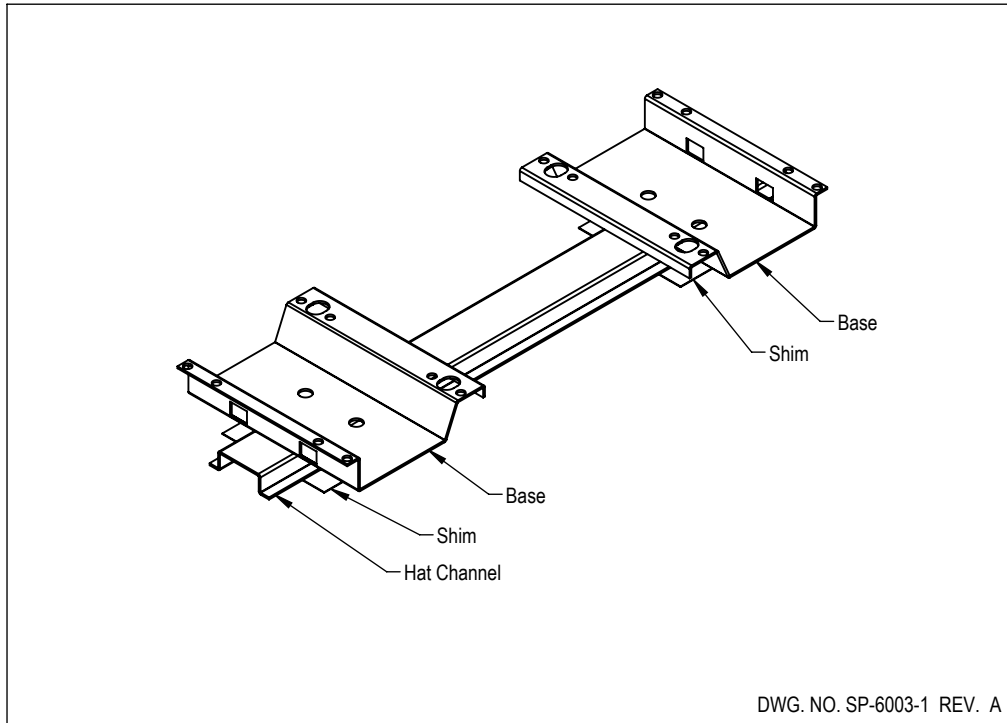
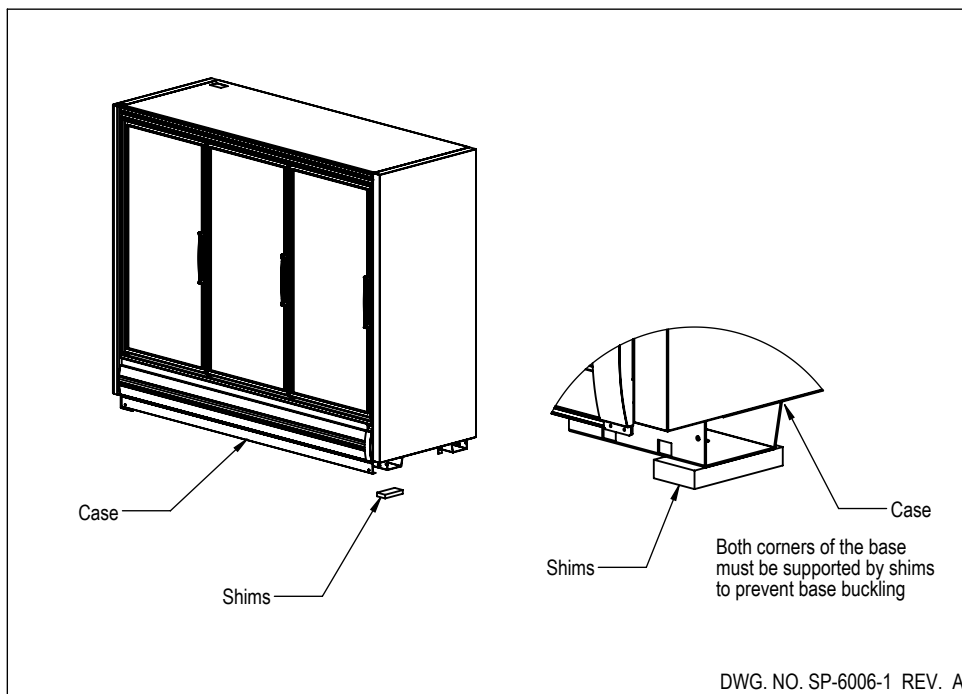

Figure 4: Shims Under Bases and Case



INSTALLATION

LEVELING (CONT.)

Figure 5: All Base Locations

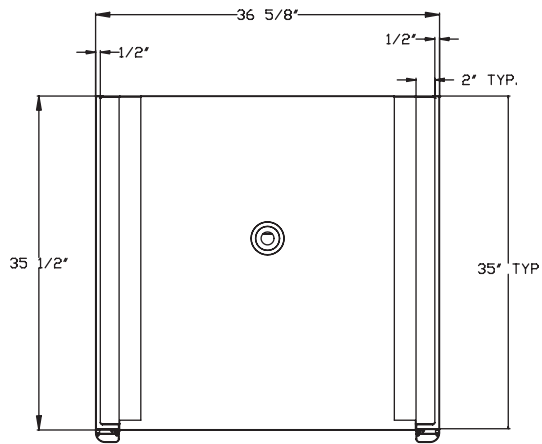

A. 1-Door Case

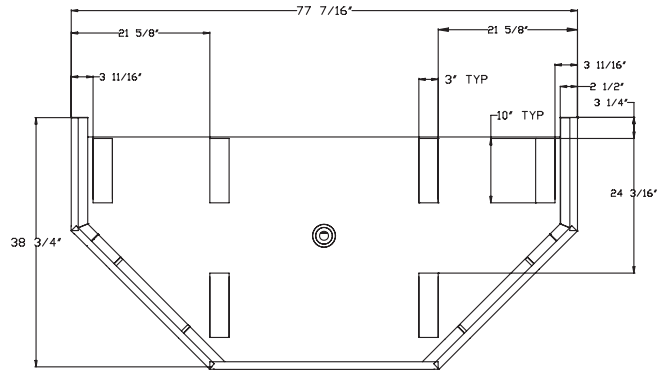

B. Wrap Around Case (WA)

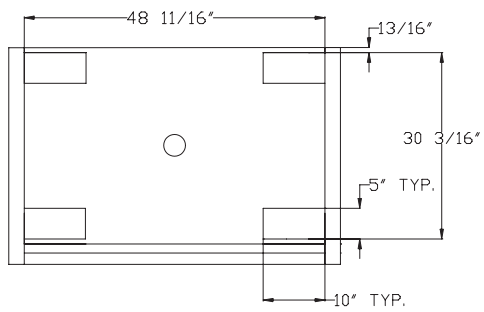

C. 24" 2-Door Case

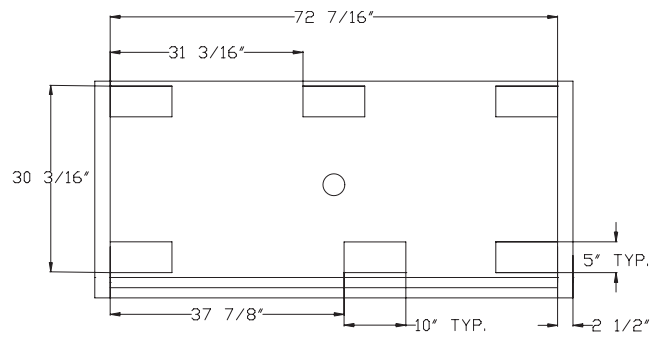

D. 24" 3-Door Case

INSTALLATION

LEVELING (CONT.)

Figure 5: All Base Locations (Cont.)

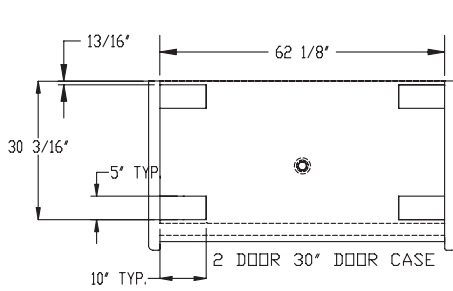

H. 30" 2-Door Case

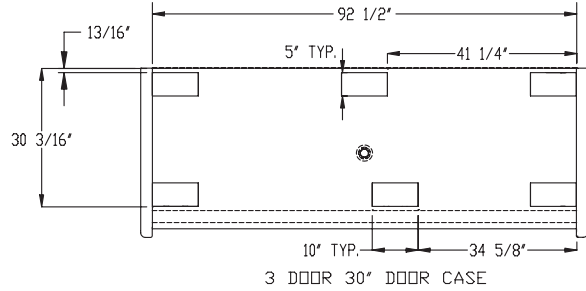

I. 30" 3-Door Case

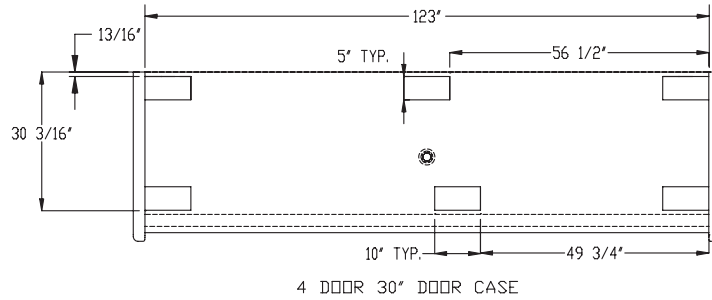

J. 30" 4-Door Case

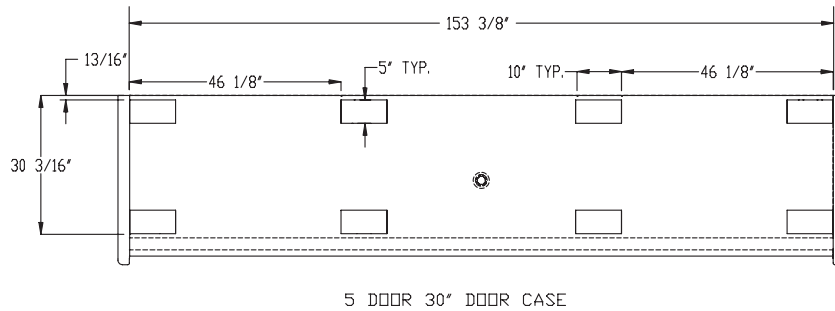

K. 30" 5-Door Case

MOVING CASES

The Back-to-Back cases are shipped with wood planks that allow the use of pipe rollers. These wood planks should be removed after the case is moved to its final location (**Figure 6 on page 11**).

The RVCZ and RVCC and BB cases have steel protective support plates under the ends (not under insulated dividers). These are designed to protect the end from Johnson Bar damage.

Use the following methods to move the cases:

MODEL	FORK LIFT FROM ENDS	JOHNSON BAR	FURNITURE DOLLY	PIPE ROLLERS	SAFE (CASE) JACKS
RVZC30 & RMZC24	✓	✓	✓		✓
RVZC BB	✓	✓	✓	✓	✓
RVZC WA	✓*	✓			✓
1-Door RVZC	✓*	✓	✓	✓	✓
RVCC30 & RMCC24	✓	✓	✓		✓
RVCC BB	✓	✓	✓	✓	✓
RMCC WA	✓	✓			✓
1-Door RVCC	✓*	✓	✓	✓	✓

* Fork lift from rear

Care should be taken when moving the cases. The doors should be secured so they cannot open while the case is moved.

Only experienced certified fork truck drivers should use fork trucks to move the cases. The case should only be lifted off the floor as high as necessary for transport. The fork truck should be driven slowly avoiding any abrupt motions or bumps.

The cases have steel protective support plates under the ends (not under insulated dividers). These are designed to protect the end panel from J-bar damage.

Care should be taken when moving the cases. The doors should be secured so they cannot open while the case is moved.

Only experienced certified forklift drivers should use forklifts to move the cases. The case should only be lifted off the floor as high as necessary for transport. The forklift should be driven slowly, avoiding any abrupt motions or bumps.

The following forklift dimensions must be maintained to avoid damaging the case when it is lifted:

2-DOOR CASES

Forks must extend from 26" to no more than 30" under the case.

3-DOOR CASES

Use 48" long forks!

Forks must extend from 39" to no more than 43" under the case.

4 & 5-DOOR CASES

Use 48" long forks!

Fork blades wider than 4" will not fit in the bases.

MOVING CASES

Spacer blocks are factory installed in the end bases of 4 and 5-door cases that use 4 1/2" bases (**Figure 7**). These blocks limit the cases forward tilt while it is being lifted and must be used when lifting 4 or 5-door cases with 4 1/2" bases.

For low shipping height applications, Zero Zone has optional expandable bases. As shipped, the base is 1 3/4" tall. It is attached with spacers that allow the base to slide away from the bottom of the case creating a gap that allows the use of a 1 1/2" thick fork truck blade (**Figure 8**).

Figure 6: Removing Wood Planks

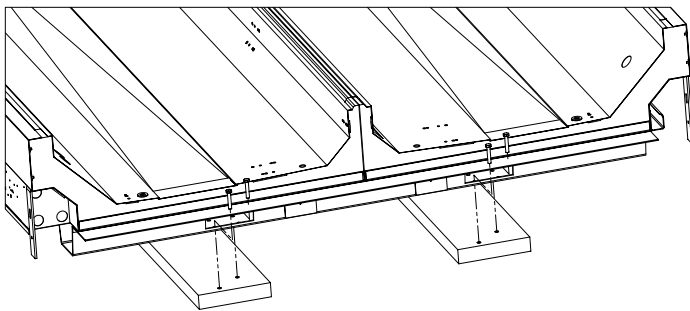

Figure 7: Wood Block Inside Base

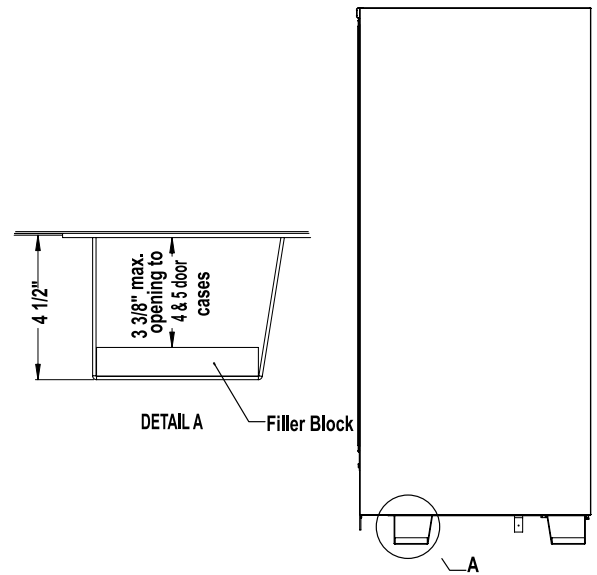
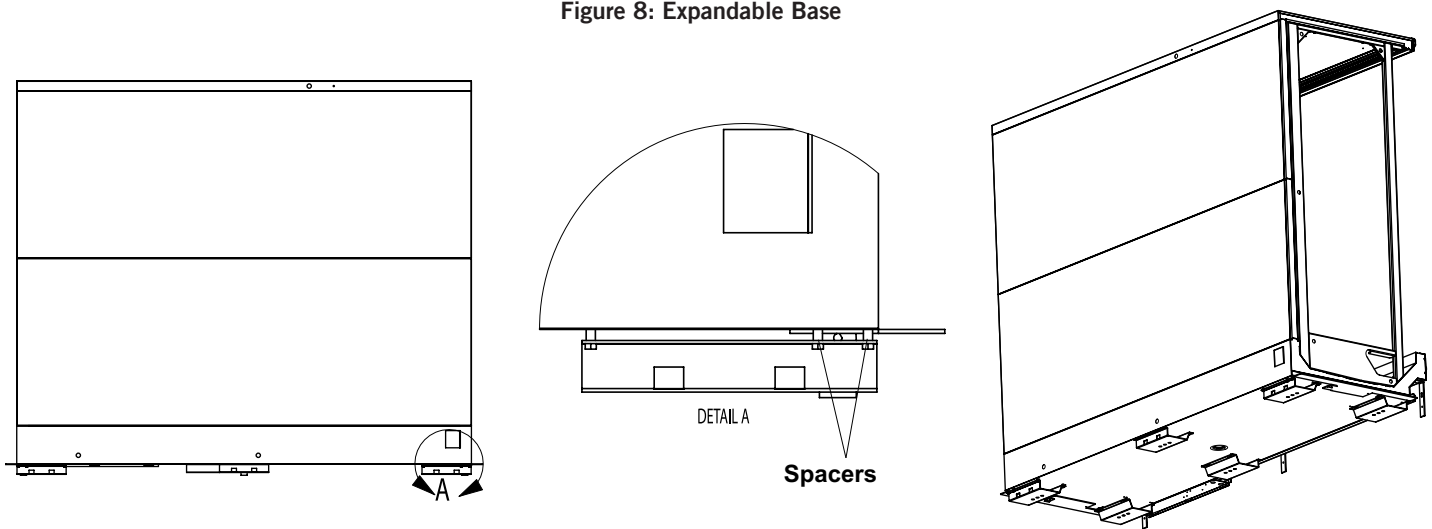

Figure 8: Expandable Base



LINEUP ASSEMBLY

Zero Zone display cases have been engineered for continuous display. This means that any number of cases can be joined together to create a display of any desired length. The bottom of the end panel is protected with a removable steel plate.

The lineup is assembled by sliding one case up to the second case and then bolting the cases together. Bolt holes for the bottom of the frame can be accessed by removing the right and left coil covers. The front and top bolt holes are visible on the steel end frame. The rear bolt holes are exposed by removing the lift-out duct on the 30" door cases and by removing pocket covers on the 24" door cases. **Figure 12 on page 13** show the bolt hole locations for each case. Bolt kits and instructions are supplied with the case.

Figure 9 gives instructions on applying caulk to the case joint before the cases are slid together. Once the cases have been caulked and slid together, start the joining bolts, but do not tighten them. Slide the t-strip between the door frames (**Figure 11 on page 13**). Begin tightening the bolts at the top rear, working down the back of the case and up the front, making sure that the front seams are flush. Bolts are not designed to pull the cases together.

Two different model cases or two different temperature cases are connected using an insulated divider. Typically the divider is factory assembled to one of the cases. Two styles of divider are provided. The first style has a panel on each side with nut inserts in the panels. Each side is bolted to the end frame. Instructions for assembly of this style are given in **Figure 13 on page 14**. The second style divider uses a thru-bolt design. The divider is attached to one of the cases using short bolts. When the case is installed, the short bolts are removed and long bolts are reinstalled to bolt both cases together. Instructions for assembly of this style case are given in **Figure 14 on page 15**. Bolts are not designed to pull the cases together.

For NSF case installation, the interior case seams need to be sealed using NSF approved caulk (not supplied) as shown in **Figure 10 on page 13**.

The end panel protector support plates should be removed after the cases are set in their final position.

Figure 9: Caulking Cases to be Joined

DO NOT APPLY EXCESS AMOUNTS OF BUTYL SEALANT THAT WOULD CAUSE IT TO SQUEEZE ONTO END FRAME METAL AREAS. Caulk sealant used to join cases and complete the sealing requirements for NSF compliance should not come in contact with butyl sealant. Apply to clean, dry surfaces free of contaminants that adversely affect adhesion and could change color of sealant joint areas over time.

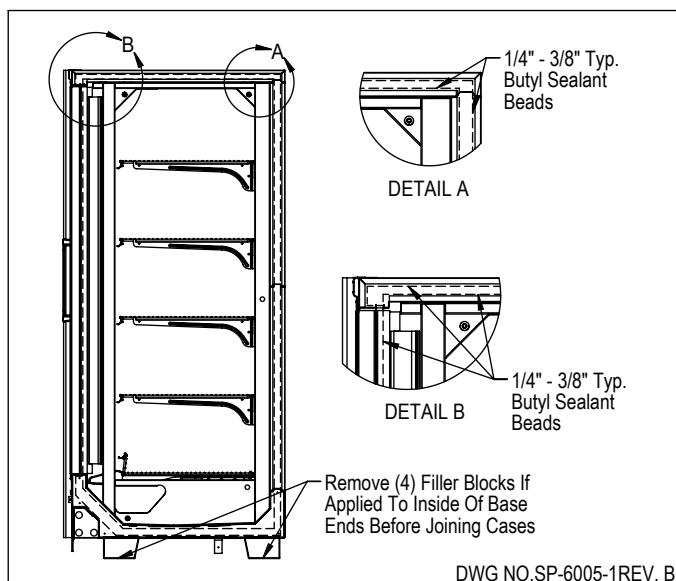

PROCEDURE FOR JOINING CASES

These procedures are critical! Failure to follow these guidelines will result in a poorly functioning case. This is especially true of low temp cases.

1. Apply two $\frac{1}{4}$ " to $\frac{3}{8}$ " wide beads of butyl sealant, $\frac{1}{2}$ " in from the inside and outside edges of foamed insulated ceiling, rear wall, base, and door frame to be joined. Apply to only one case joint to avoid excessive amounts of butyl sealant that would squeeze out of the joint. Sealant is not applied to the structural steel end frames. After cases are joined, caulk the top and back exterior seams (if possible) at this time.
2. When joining ends of cases, caulk sealant should be applied in the same manner for joints.

LINEUP ASSEMBLY

Figure 10: Required Sealing for NSF-Approved Installations

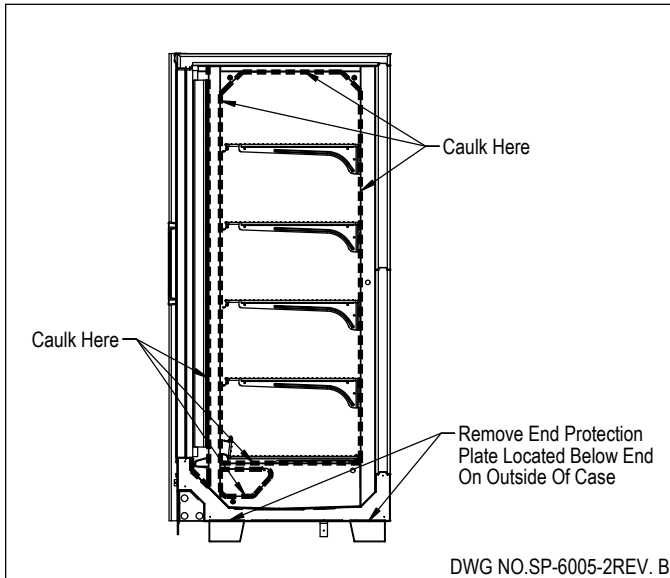

SURFACE TEMPERATURE SHOULD BE ABOVE 40°F AND FREE OF FROST.

1. Apply nonporous/nonabsorbent good quality NSF approved silicon caulk sealant or (Manus Bond 75-AM) after end panel is joined to case or when second case is joined with first case.
2. Apply silicon caulk-sealant bead to areas shown to meet sealant requirements for NSF approved installations.
3. Apply small beads of sealant smoothly, but do not thin or feather excessively, because it may affect adhesion.

NOTE: Field caulk is applied continuously.

Figure 11: T-Strips

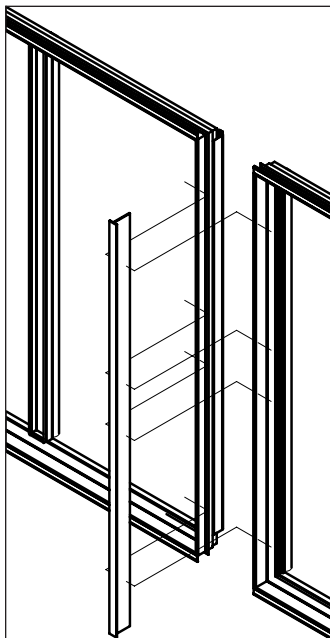
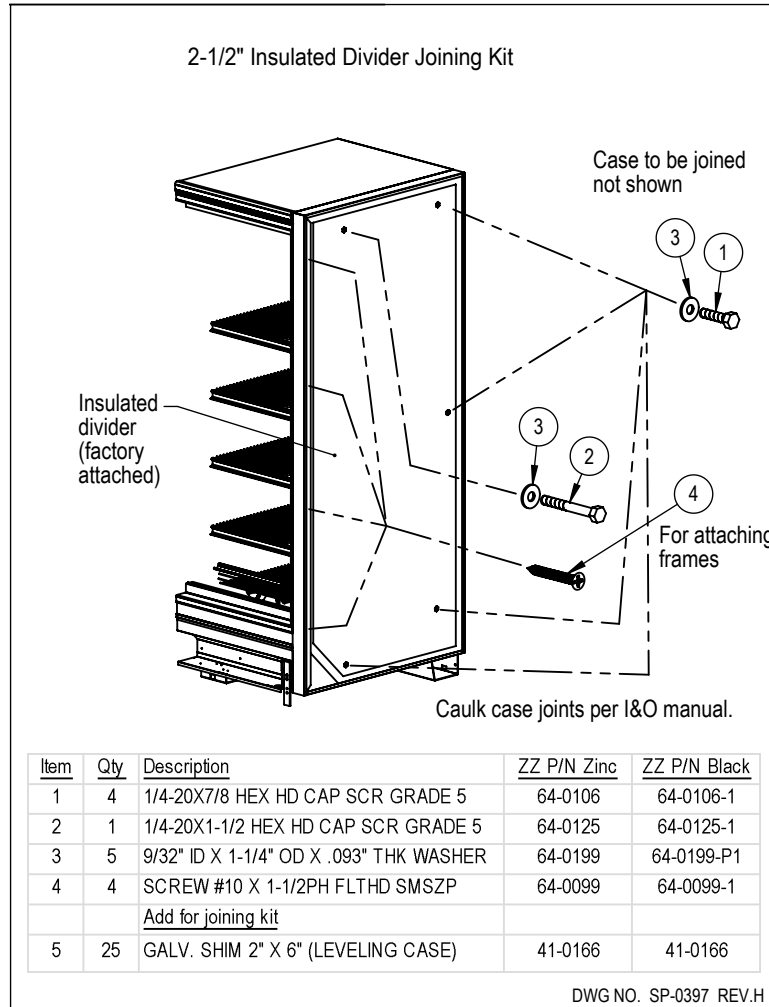

Figure 12: Joining 24" and 30" Door Cases

Item	Qty	Description	ZZ P/N Zinc	ZZ P/N Black
1	5	3/8"-16 x 1" Hex Hd Cap Screw	64-0287	64-0287-P1
2	10	3/8" Flat Washers	64-0034	64-0034-P1
3	5	3/8"-16 Hex Nut	60-0064	60-0064-P1
4	4	#10-24 x 1/2" Slit Truss Hd Screw	64-0145	64-0145-P1
5	4	#10-24 Nut, Slit Truss Hd Shoulder	64-0146	64-0146-P1
Add For Joining Kits:				
6	25	Galv. Shims 2" x 6"	41-0166	41-0166

LINEUP ASSEMBLY

Figure 13: Joining Insulated Dividers with Nut Inserts



LINEUP ASSEMBLY

Figure 14: Joining Insulated Dividers with Thru-Bolts

2-1/2" INSULATED DIVIDER JOINING KIT WITH THRU BOLTING
 VZ TO VC VC TO VZ VZT2 TO VCT2 OR VCT2 TO VZT2

- 1) CAULK CASE JOINTS FOLLOWING SP-0420 TECH BULLETIN CASE JOINING AND SEALING NSF FIELD CAULKING.
- 2) ALIGN OPPOSITE ENDS OF TWO CASES TO BE JOINED.
- 3) THERE ARE 5 BOLTS ATTACHING THE DIVIDER TO THE CASE. REPLACE EACH OF THESE BOLTS ONE AT A TIME. DO NOT REMOVE DIVIDER FROM CASE.
 - 3a) REMOVE ONE BOLT AND ONE WASHER USED TO ATTACH 2-1/2" INSULATED DIVIDER PANEL.
 - 3b) INSTALL ONE LONGER (ITEM 1) 1/4-20 X 3-1/2" GRADE 8 BOLT AND ONE (ITEM 3) WASHER IN THE SAME LOCATION AND ORIENTATION OF THE ORIGINAL BOLT.
 - 3c) TIGHTEN TO SECURE INSULATED DIVIDER. THE BOLT WILL TIGHTEN TO THE PANEL AND THE END OF THE BOLT WILL EXTEND THRU INTO THE NEXT CASE.
 - 3d) REPEAT UNTIL FIVE BOLTS HAVE BEEN REPLACED.
- 4) HAND TIGHTEN ITEM 3) WASHERS AND (ITEM 2) GRADE 8 NUTS ON OPPOSITE CASE.
- 5) MAKE SURE INSULATED DIVIDER IS ALIGNED WITH CASE.
- 6) ALTERNATELY TIGHTEN EACH BOLT EQUALLY UNTIL THE CASES ARE JOINED TOGETHER EVENLY FORMING A TIGHT SEAL BETWEEN THE DIVIDER AND THE CASE. BOLTS ARE NOT DESIGNED TO PULL CASES TOGETHER.
- 7) FINISH ATTACHMENT OF THE SECOND CASE FRAME WITH FOUR (ITEM 4) SCREWS.

ITEM	QTY	DESCRIPTION	ZZ PART NO.	ZZ PART NO. BLACK
1	(5)	BOLT HEX TAP 1/4-20 x 3-1/2" HEX HD BOLT, GRD 8	64-0406	64-0406-P1
2	(5)	NUT HEX 1/4-20 GRD 8	64-0308	64-0308-P1
3	(10)	WASHER 9/32" ID 1-1/4" OD .093TK FNDR	64-0199	64-0199-P1
4	(4)	SCREW #10 X 1.0" PH FLTHD SMSZP (FRAME) ADD FOR JOINING KIT	64-0269	64-0269-P1
5	(25)	GALV. SHIM 2" X 6" (LEVELING CASE)		

SP-1097 REV C

DRAIN LINE

The drain is located at the center of the case in the floor pan. The drain can be reached by removing the center coil covers and then removing a fan motor. The 1" PVC drain outlet is located at the center front of the case behind the kickplate.

Install the tee to the outlet pipe and a drain trap to the tee. Plug the open end of the tee using the clean-out plug supplied with the drain trap kit. The drain line must be pitched away from the case. The tee, drain trap and plug are supplied with the case. The factory installs a drain support at the front of the case on all 30" door cases. We supply a trap support that is field mounted to the case (**Figure 15**). The drain trap must be level. The drain trap should be primed with water after installation. The drain line must be pitched away from the case enough to insure proper drainage. Consult your local codes for minimum requirements.

Figure 15: Trap Support

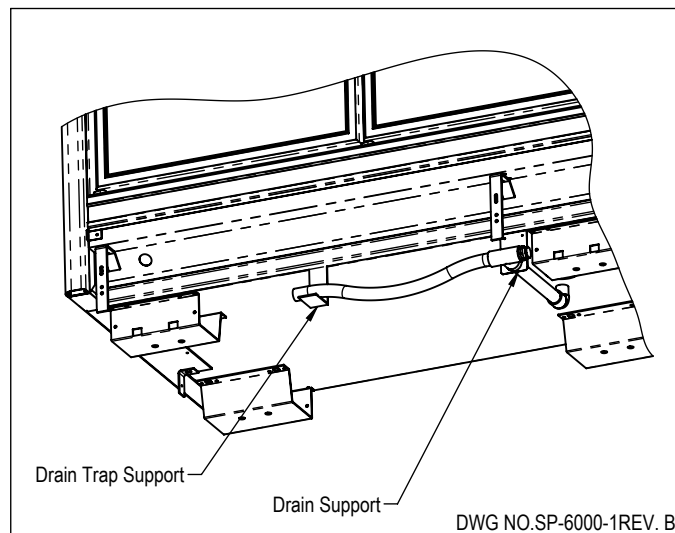

BUMPER AND KICKPLATE

A Zero Zone bumper is standard on all case models and should be installed at the bottom front of the case. Various bumper styles are available (**Figure 16 on page 18**). The kickplate assembly is adjustable to compensate for uneven floors. The bumper end cap is factory installed on bumpers for cases with end panels that do not include Euro trim.

INSTALLING END KICKPLATE

(**Figure 17 on page 18**)

The end kickplate attaches to the small black bracket attached to each side of the case with an end. The kickplate can be adjusted vertically to match the height of the floor below it.

1. Attach a Tinnerman clip to the side bumper support.
2. Place the side kickplate against the Tinnerman clip on the side bracket.
3. Install the black $\frac{3}{4}$ " screw through the side kickplate and into the Tinnerman clip. A scratch-awl or similar tool can be used to line up the holes.
4. The front of the side kickplate is located behind the front kickplate and attached with screws to the front kickplate.

INSTALLING BUMPER

(**Figure 17 on page 18**)

The front kickplate and bumper attaches using $1\frac{1}{2}$ " screws attached to brackets located on the front of the case. The kickplate can be adjusted up and down to fit the height of the floor below it.

1. Starting from the left end of the lineup, attach a Tinnerman clip to each bumper support bracket. Locate them over the hole for the bumper.
2. Attach the kickplate splice to the right side of the kickplate using the $\frac{3}{4}$ " screw in the lower hole.
3. Lean the kickplate against the bumper support bracket.
4. Hang the bumper on the case. The kickplate should be located behind the bumper.
5. Install the black $1\frac{1}{2}$ " screw through the bumper, kickplate, kickplate splice, and into the Tinnerman clip. A scratch-awl or similar tool can be used to line up the holes.
6. Follow these steps to install the next bumper in the lineup. A bumper splice (provided) should be installed between the two cases. Center the splice and adjust the height so the decorative tape (if applicable) lines up. Using self-tapping screws (provided), attach the upper portion of the splice using the predrilled holes in the splice. Then with two more screws, attach the lower half.

BUMPER AND KICKPLATE

Figure 16: Other Style Bumpers

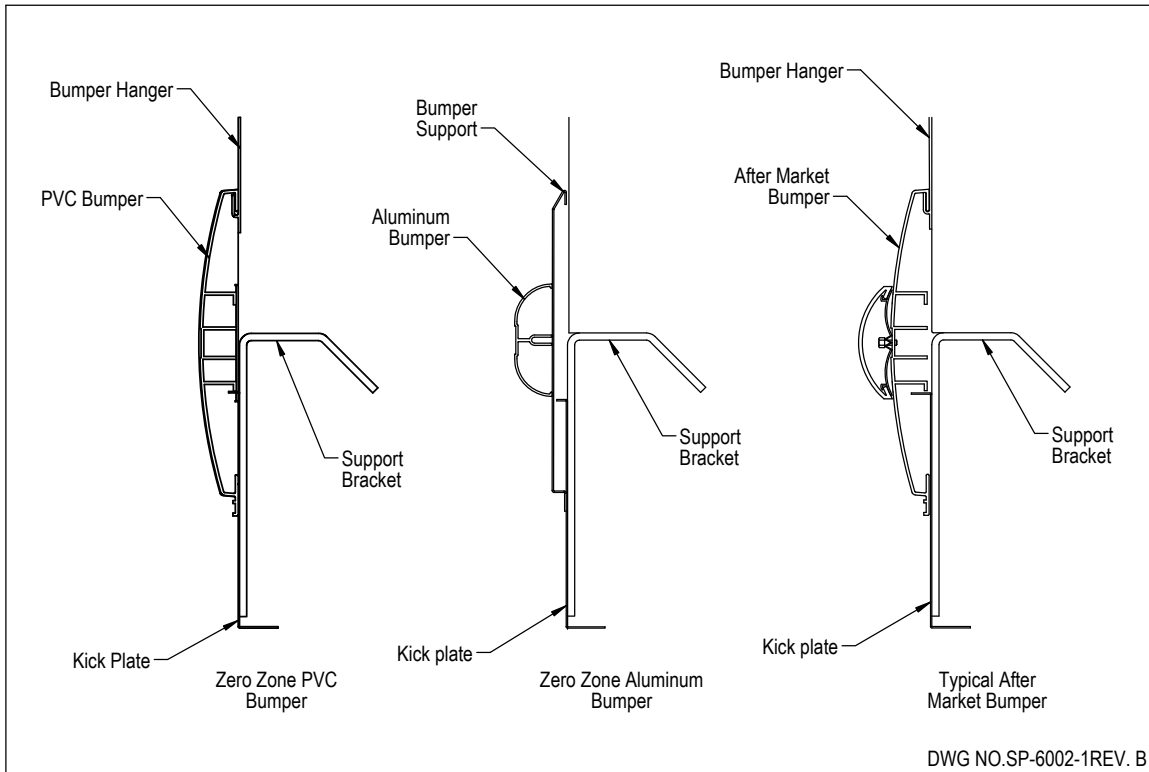
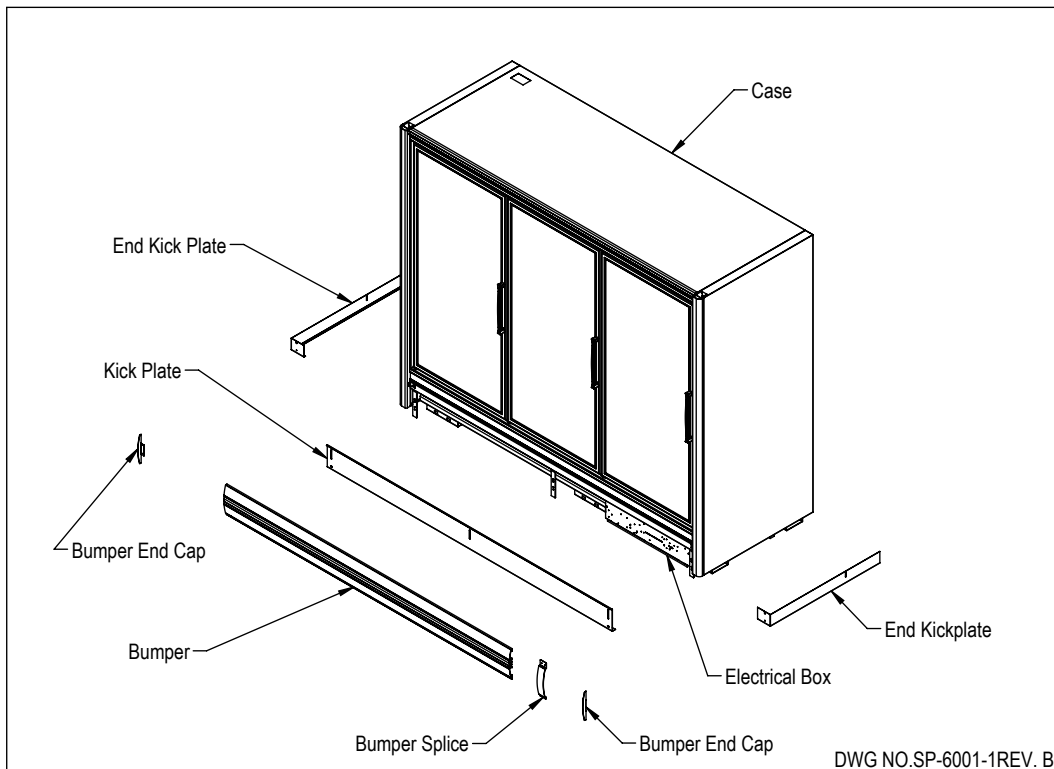

Figure 17: Installing Bumper and Kickplate



BUMPER AND KICKPLATE

UNDER CASE RETURN AIR FLOW ASSEMBLY INSTRUCTIONS

To assemble the bumper for under case return air flow (if requested), a spacer (provided) must be inserted between the bumper and kickplate (**Figure 18**). The spacer is held in place with the standard black assembly screw used to attach the bumper. One $\frac{3}{8}$ " spacer is required at each screw location (2 spacers on a 2-door, 3 spacers on a 3-door, etc.).

1. To ease installation, hook the bumper to the case and position the kickplate. Then pull the bottom edge of the bumper forward, hold the spacer in place, and then insert the assembly screw through the bumper, spacer, kickplate, bumper bracket and into the Tinnerman clip.
2. With the spacers in place, air will be allowed to flow between the bumper and kickplate and then underneath the case. The target airflow rate under the case should be 50 cfm/door.

Note: An optional louvered kickplate is available.

Figure 18: Bumper Air Flow

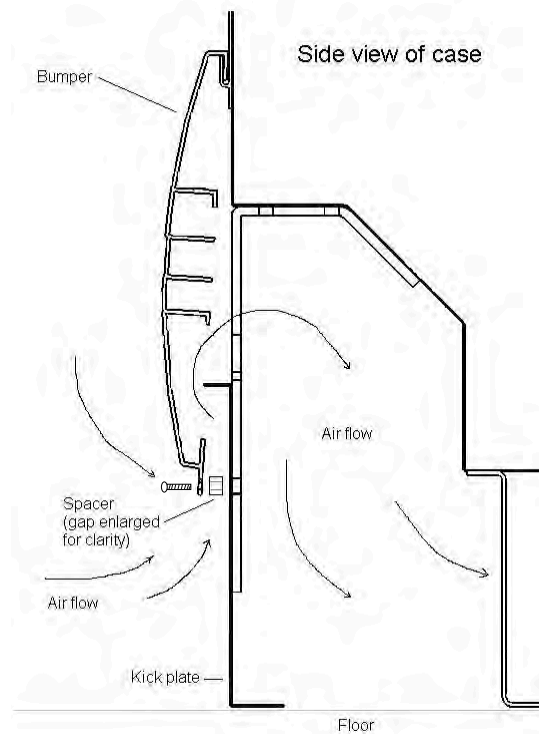

GENERAL INFORMATION

CLEANING

The case and doors are cleaned prior to shipping. However, the case should be thoroughly cleaned before start-up and routinely thereafter to maintain a clean appearance. Use mild detergent and warm water (never an abrasive cleaner) to wipe out the inside of the case. Wash down all glass doors with glass cleaner. Do not use any products containing silicon on anti-fog glass coatings. Clean interior glass reduces fogging and increases visibility. The case will remain bright and sparkling with just a few minutes of cleaning each week. Internal components can be cleaned after removal of access panels. The case drain should be regularly cleared of debris and price tags.

Coils may be cleaned with a garden hose or pails of water. Cases that use pump, drain pans and condensate evaporators should be cleaned with a minimum amount of water. The drain should be blocked and the water removed with a shop vacuum.

Do not use high-pressure water or steam to clean the interior.

SHELF LOCATION

- The shelves are adjustable in 1" increments on cantilever shelf cases and may be located in any position for best display advantage.
- Be sure brackets are completely seated.
- Wire shelf brackets are stamped with "R" for Right and "L" for left to aid installation.

SHELVES

Zero Zone manufactures many different styles of shelves, baskets, and product stops. The shelves and baskets are placed on the shelf brackets for shipping. Solid shelves have three parts. A solid center section and two snap-in brackets. Some of the baskets may be reversed and used as a typical shelf. The fully assembled shelves are installed in cases prior to shipping.

Solid shelves can be disassembled for cleaning. A screwdriver can be used to spread the snap open to remove the brackets from the center section.

LOADING THE CASE

The case may be loaded with merchandise after it has been operated for at least 24 hours with correct case temperature and proper control operation. While loading the shelves, leave an air space between the top of the merchandise and the shelf above it so the customer can remove the merchandise. The air space allows an air curtain on top of the product. Product should not extend beyond the front of the shelves or block the return air grill.

The shelf loads are as follows:

ITEM	SHELF DESCRIPTION	MAXIMUM LOAD PER SHELF
1	22" and 24" deep	250 lbs.
2	27" deep	400 lbs.
3	Bakery or Meat Brackets	
	at 0°	250 lbs.
	at 5°	250 lbs.
	at 10°	150 lbs.
	at 15°	100 lbs.

Some deflection may occur under higher loads.

GENERAL INFORMATION

LIGHT SWITCH

The light switch is located inside the right-hand door. Turn the light switch off during the initial case temperature pull down to prevent the case lights from cycling off and on. Always turn the lights off when replacing lamps.

CASE THERMOMETER

The cases are shipped with 2 thermometers. One thermometer is factory mounted in the discharge air stream. The second thermometer is shipped loose and should be installed in the warmest product location. Specific instructions are packaged with the shipped loose thermometer.

SERVICE

See **Figure 33 on page 41** and **Figure 35 on page 43** for the typical component layout of the 30" door case. See **Figure 34 on page 41** and **Figure 36 on page 43** for the typical component layout of the 24" door cases.

The bumper and kickplate must be removed to gain access to the drain clean out and electrical connections. Disassemble the bumper and kickplate by removing the 2 or 3 metal screws located in the kick rail. The bumper assembly can be lifted up and removed from the case. The kickplate can be removed, exposing the electric tray cover and drain (**Figure 17 on page 18**).

EVAPORATOR

The evaporator coil, located at the rear bottom of the case, is factory assembled with distributor, expansion valve, and other refrigeration components. To inspect the coil, remove the center or left of center coil cover. A small inspection window is located at the rear of the case. To inspect the entire coil, remove the remaining coil covers and raise the evaporator cover.

EXPANSION VALVE

Unless otherwise specified, a superheat adjustable externally equalized thermostatic expansion valve with a removable strainer and pressure limiting charge (low temp only) is mounted to the evaporator coil. The valve is not preset. Adjust the superheat setting for maximum coil effectiveness. Typical superheat settings are between 6°F and 10°F. Close coupled systems should use the higher superheat setting to minimize the chance of liquid flood back. To adjust the expansion valve, remove the right end coil cover. Remove the cap from the bottom of the valve. When looking at the valve stem end, turn the valve stem counterclockwise to decrease superheat. Turn the valve stem clockwise to increase super heat. Measure the suction line temperature at the expansion valve sensing bulb and compare it to the suction temperature corresponding to the saturated pressure. Make sure that line pressure drop is taken into account.

Turn the valve stem only ¼ turn at a time and allow sufficient time (20 to 30 minutes) for the valve to settle before making any further adjustments. Replace the valve stem cap after the valve superheat has been adjusted. **BE CERTAIN THE VALVE STEM CAP IS WIPED DRY FIRST.**



Caution!

DISCONNECT POWER TO THE CASE BEFORE SERVICING ELECTRICAL COMPONENTS TO AVOID PERSONAL INJURY AND DAMAGE TO THE UNIT.

EVAPORATOR FANS

Air is circulated throughout the case with 115 volt low temperature fan motors. These motors must be operating at all times except during defrost in low temp cases. Fan motors should be replaced with motors having the same characteristics including type, physical size, lubricant temperature range, wattage and RPM. Fan blades should be replaced with factory original equipment part.

GENERAL INFORMATION

SERVICE (CONT.)

CONDENSATE EVAPORATION SYSTEM

Zero Zone remote cases can be equipped with an automatic condensate evaporation system. The system uses a pump and drain pan located behind the kickplate and a condensate evaporator pan mounted on the top of the case.

Condensate water and any liquid spilled in the case drains out into the drain pan. The pump is equipped with a float that turns the pump on when there is a sufficient liquid level. Liquid is pumped through a plastic hose through a check valve and into the condensate evaporation pan. The evaporation pan is equipped with a heater and a float switch to turn on when the heater is submerged in liquid. When the heater is energized, the pan will be extremely hot and should not be touched. The pump and condensate pan should be cleaned regularly. Any spilled product should be cleaned to prevent odors.

AIR CURTAIN VELOCITY

Air curtain velocity is affected by stocking levels, coil frost loads, temperature and fan condition. The measurement method also affects the reading. Zero Zone recommends using an Anor Velometer Jr., set to the 0-to-800 fpm range. Air velocity should be measured at the back edge of the discharge air honeycomb, at the center of the middle door in the case (other doors have slightly lower velocity). A typical low temp velocity reading is 400 to 500 feet per minute in a fully-packed low temp case, after the case has defrosted and pulled down to operating temperature. Air curtain velocity in a partially-packed display case is significantly lower because more air exits the back wall duct holes. In medium temp cases, the velocity should be 300 to 400 feet per minute after the case has defrosted and pulled down to temperature.

FAN REMOVAL

1. Turn off power to fans. Remove coil cover.
2. Unplug fan from fan power supply plug located on the front face of the fan housing.
3. Remove the fan blade nut and fan blade.
4. Remove the two mounting bolts and remove the fan assembly from the fan housing.
5. Remove the three fan motor mounting screws from the back of the fan motor.
6. Reverse steps 1 - 5 to install.

LED POWER SUPPLIES AND BALLASTS

Most Zero Zone case ballasts or LED power supplies are located in the door mullion. Ballasts for the 1-door and WA, are located behind the kickplate.

FLUORESCENT LIGHTING

These systems use a lens to direct light output evenly across the shelves. Turn off power before servicing the lamps. The lens must be removed to access the lamp. The lens must be replaced after servicing for proper operation. Detailed information is contained in the door instruction booklet.

REFRIGERATION

GENERAL

Unless otherwise specified, the liquid and suction connections are made inside the case under the evaporator fan/coil cover. Refrigerant piping may enter the case through the front left bottom, the left rear bottom of case, or the left rear top of case. The copper pipe should not touch or rub on the edges of the sheet metal. After connections have been made, the refrigeration access hole in the case must be sealed completely with an aerosol-dispensed Urethane insulation or equivalent (i.e. Great Stuff). Penetrations made in sheet metal baffles should also be sealed (**Figure 19**).

Figure 19: Penetration Sealing

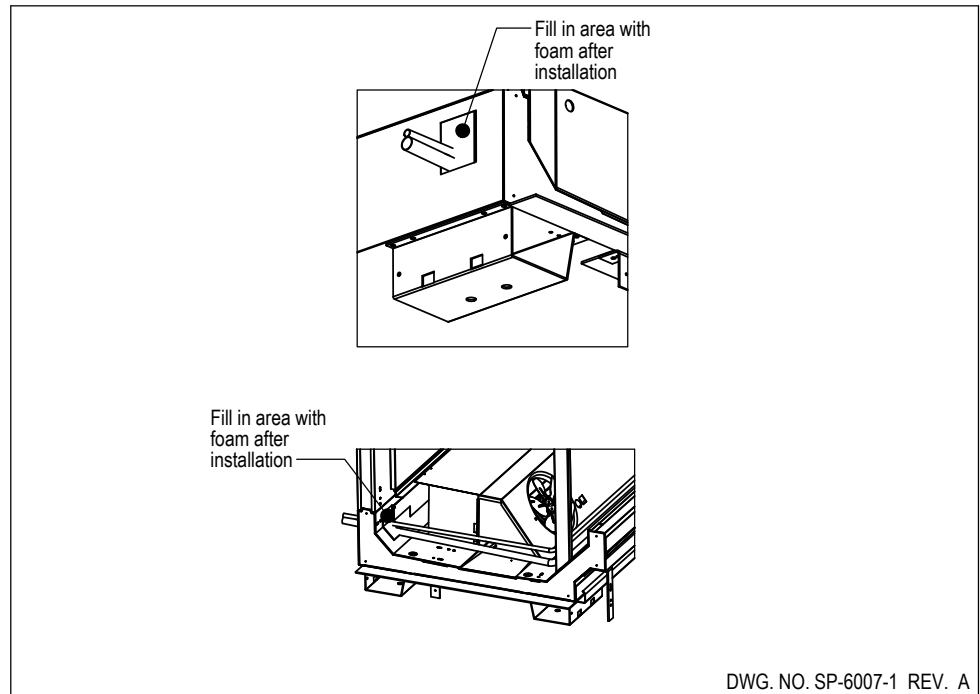

REFRIGERANT PIPING

Correct refrigeration line sizing and installation is essential for proper system operation. **Figure 23 on page 26, Figure 24 on page 27, and Figure 25 on page 28** are for Evolution (V) model cases. Contact the factory for line sizing for the Maximizer (M) model cases. A P-trap must be installed at the bottom of all vertical suction risers (**Figure 20 on page 24**). Various risers are available as a factory installed option.

When two or more case sections are connected to one compressor, the main liquid and suction line for the group should be run through the cases and be brought out through the refrigeration outlet of one case only. The factory recommends one riser per circuit/system for hot gas defrost when using top back refrigeration exit. Circuit risers are available as a factory installed option. On 30" wide door cases with suction lines over 1 3/8" diameter, a P-trap made with 45° elbows is required (**Figure 20 on page 24**). A piping chase in front of the fan shroud allows the refrigerant lines to be run through the right or left end frame.

Piping should not be placed near the electric defrost heaters. The defrost heaters on the 30" door cases will grow one inch to the left of the coil when they reach operating temperature.

The compressor should be installed as close as possible to the cases to reduce pressure drop. Install a shallow trap at the bottom of the riser.

The best location for the liquid line drier is inside the case compartment. However, it may be installed near the compressor for easy maintenance. Install moisture indicating sight glass at the outlet end of the drier.

A low pressure or temperature control can be used to control case temperature. The control should be selected with adequate contact capacity for the switching load. In rack systems, an evaporator pressure-regulating valve may be used to control the evaporating temperature.

The settings (**Figure 21 on page 25**) are approximate due to variations in gauge accuracy, differences in compressor efficiency, line pressure drop and superheat settings. Before making adjustments for store or stocking conditions, make sure the superheat is set. Close coupled systems typically run at the higher end of this range to avoid flood back.

REFRIGERATION

GENERAL (CONT.)

TEMPERATURE CONTROL ADJUSTMENT

When factory installed, the temperature control is located toward the right end of the case in the electrical box. The sensing bulb is located under the coil cover on the back side of the fan shroud. It can be wired in series with the low-pressure (L.P.) control. It can also be used in a pump down system by wiring it in series with the liquid solenoid valve. A thermostat is shown in **Figure 22 on page 25**.

Discharge air temperature probes for electronic case controllers may be installed in many different customer specified locations including, but not limited to, honeycomb, ceiling pocket cover, rear wall, and return air.

LEAK-CHECK/EVACUATION/CHARGING

After all of the refrigeration piping and system components have been assembled, the entire system must be pressurized and checked for leaks.

When the system is leak free, evacuate with a deep vacuum pump. Triple evacuation to a minimum of 500 microns and nitrogen sweep is recommended. After the system has been thoroughly evacuated of all moisture and noncondensable gas, charge the system with the proper refrigerant, using "hi-side/low-side" charging techniques.

Figure 20: 45° Elbow Suction Line

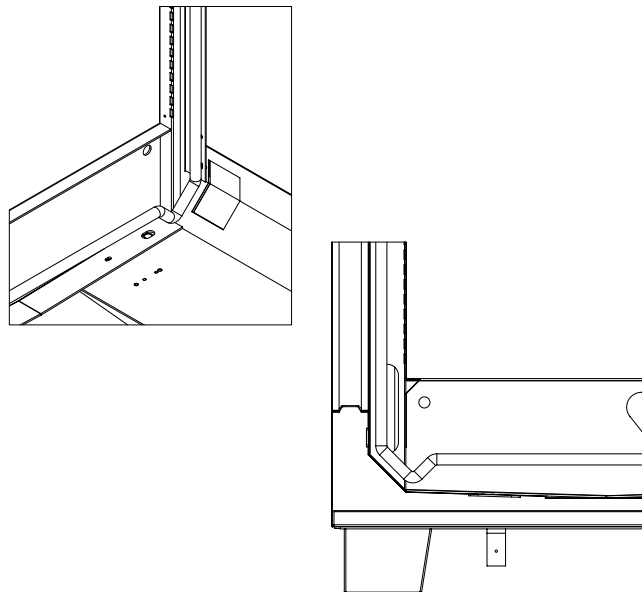

REFRIGERATION

GENERAL (CONT.)

Figure 21: Temperature Settings

R 404A FROZEN FOOD	R 404A ICE CREAM	R 404A MEDIUM TEMP
RACK SYSTEMS VZ and VZT 30" door Evaporator temp -7°F	RACK SYSTEMS VZ and VZT 30" door Evaporator temp -16°F	RACK SYSTEMS VC and VCT2 30" door Evaporator temp +28°F
MZ 24" door and WA Evaporator temp -11°F	MZ 24" door and WA Evaporator temp -18°F	MC 24" door and WA Evaporator temp +25°F
CONDENSING UNIT VZ and VZT 30" door Condensing unit cut-in 35 psig Condensing unit cut-out 24 psig	CONDENSING UNIT VZ and VZT 30" door Condensing unit cut-in 27 psig Condensing unit cut-out 16 psig	CONDENSING UNIT VC and VCT2 30" door Condensing unit cut-in 74 psig Condensing unit cut-out 62 psig
MZ 24" door and WA Condensing unit cut-in 33 psig Condensing unit cut-out 21 psig	MZ 24" door and WA Condensing unit cut-in 26 psig Condensing unit cut-out 15 psig	MC 24" door and WA Condensing unit cut-in 70 psig Condensing unit cut-out 58 psig
RETURN & DISCHARGE AIR TEMPERATURE Return air temp cut-in +6°F Return air temp cut-out 0°F Discharge air temp cut-in +3°F Discharge air temp cut-out -3°F	RETURN & DISCHARGE AIR TEMPERATURE Return air temp cut-in -3°F Return air temp cut-out -9°F Discharge air temp cut-in 0°F Discharge air temp cut-out -12°F	RETURN & DISCHARGE AIR TEMPERATURE Return air temp cut-in 30°F Return air temp cut-out 34°F Discharge air temp cut-in 33°F Discharge air temp cut-out 37°F

Note: These set points may require optimization for your applications to prevent short or delayed cycling.

Figure 22: Temperature control

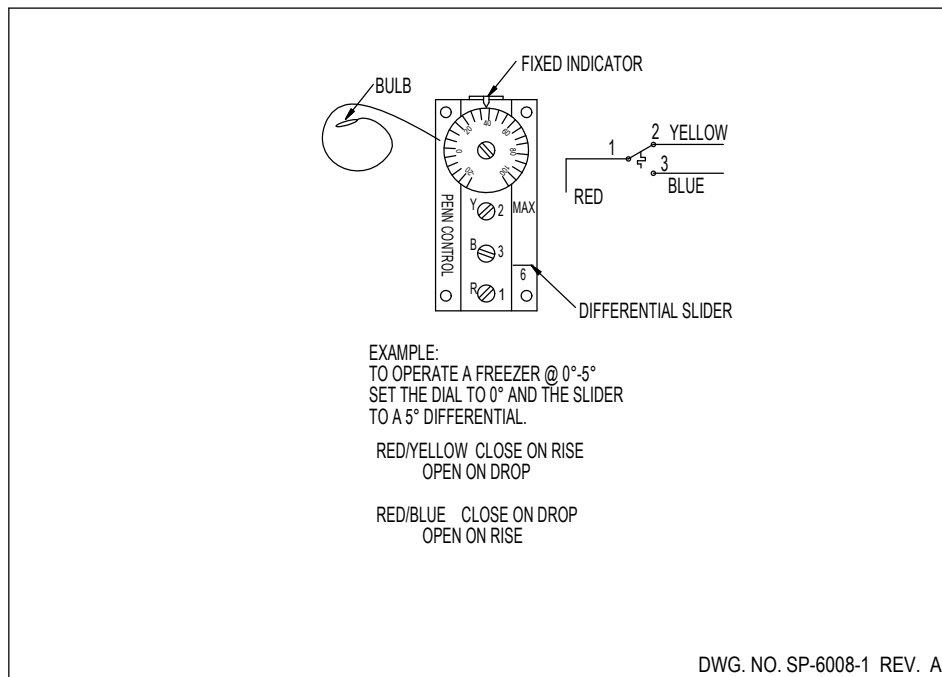

REFRIGERATION

LOW TEMP

Figure 23: Refrigeration Line Sizing - Frozen Foods

R-404 Line Sizing Tables for Zero Zone VZ Frozen Food Freezer (-7°F Evaporator Temperature)

Liquid Line Sizing - Electric Defrost*

Up to 50 equivalent feet

90°F Liquid, 2°F Pressure Drop[‡]

For rated Btuh:		
From	To	Liquid Line
0	7,300	1/4 [†]
7,310	15,000	5/16 [*]
15,010	27,300	3/8
27,310	64,600	1/2
64,610	122,000	5/8

Up to 100 equivalent feet

90°F Liquid, 2°F Pressure Drop[‡]

For rated Btuh:		
From	To	Liquid Line
0	4,970	1/4 [†]
4,980	10,300	5/16 [*]
10,310	18,700	3/8
18,710	44,300	1/2
44,310	83,200	5/8

Up to 150 equivalent feet

90°F Liquid, 2°F Pressure Drop[‡]

For rated Btuh:		
From	To	Liquid Line
0	3,960	1/4 [†]
3,970	8,150	5/16 [*]
8,160	14,900	3/8
14,910	35,500	1/2
35,510	66,700	5/8
66,710	111,000	7/8 [†]

Up to 200 equivalent feet

90°F Liquid, 2°F Pressure Drop[‡]

For rated Btuh:		
From	To	Liquid Line
0	3,370	1/4 [†]
3,380	6,940	5/16 [*]
6,950	12,700	3/8
12,710	30,300	1/2
30,310	56,900	5/8
56,910	94,800	7/8 [†]

* For hot gas defrost, use a liquid line one size larger than shown.

[‡] For 1°F pressure drop, multiply rated Btuh by 1.45 before using the Liquid Line Sizing Table.

^{*} Larger liquid line size may be used (such as 3/8), if preferred.

[†] 3/4 liquid line may be used to reduce cost.

Liquid Correction Factors for Liquid Line Sizing Table - Use Maximum Liquid Temperature

For maximum liquid temperatures other than 90°F, multiply rated Btuh by liquid correction factor before using the Liquid Line Sizing Table

Maximum Liquid Temperature:	40°F	50°F	60°F	70°F	80°F	90°F	100°F	110°F	120°F
Liquid Correction Factor:	0.96	0.95	0.95	0.95	0.97	1.00	1.05	1.12	1.21

Suction Horizontal Line Sizing

Up to 50 equivalent feet

90°F Liquid, 2°F Pressure Drop[‡]

For rated Btuh:		
From	To	Horizontal
0	1,730	3/8 ^{**}
1,740	4,100	1/2 ^{**}
4,110	7,700	5/8 ^{**}
7,710	12,800	7/8 [†]
12,810	20,300	7/8
20,310	41,000	1-1/8
41,010	71,400	1-3/8
71,410	113,000	1-5/8

Up to 100 equivalent feet

90°F Liquid, 2°F Pressure Drop[‡]

For rated Btuh:		
From	To	Horizontal
0	1,180	3/8 ^{**}
1,190	2,810	1/2 ^{**}
2,820	5,280	5/8 ^{**}
5,290	8,780	7/8 [†]
8,790	14,000	7/8
14,010	28,200	1-1/8
28,210	49,200	1-3/8
49,210	77,800	1-5/8

Up to 150 equivalent feet

90°F Liquid, 2°F Pressure Drop[‡]

For rated Btuh:		
From	To	Horizontal
0	940	3/8 ^{**}
950	2,240	1/2 ^{**}
2,250	4,220	5/8 ^{**}
4,230	7,030	7/8 [†]
7,040	11,200	7/8
11,210	22,700	1-1/8
22,710	39,500	1-3/8
39,510	62,500	1-5/8
62,510	130,000	2-1/8

Up to 200 equivalent feet

90°F Liquid, 2°F Pressure Drop[‡]

For rated Btuh:		
From	To	Horizontal
0	800	3/8 ^{**}
810	1,910	1/2 ^{**}
1,920	3,600	5/8 ^{**}
3,610	6,000	7/8 [†]
6,010	9,530	7/8
9,540	19,400	1-1/8
19,410	33,800	1-3/8
33,810	53,500	1-5/8
53,510	112,000	2-1/8

[‡] For 1°F pressure drop, multiply rated BTU by 1.44 before using the Suction Horizontal Line Sizing Table.

^{**} Larger suction horizontal line size may be used, if preferred.

[†] 3/4 horizontal suction line may be used to reduce cost.

Liquid Correction Factors for Suction Horizontal Line Sizing Table - Use Maximum Liquid Temperature

For maximum liquid temperatures other than 90°F, multiply rated Btuh by liquid correction factor before using the Suction Horizontal Line Sizing Table

Maximum Liquid Temperature:	40°F	50°F	60°F	70°F	80°F	90°F	100°F	110°F	120°F
Liquid Correction Factor:	0.72	0.76	0.81	0.86	0.92	1.00	1.09	1.21	1.37

Suction Vertical Riser Sizing

Maximum Allowable Riser Size For Adequate Oil Return*

70°F Minimum Liquid Temperature, using 0.35 PSI Per 100 Feet (per 2006 ASHRAE Handbook - Refrigeration).

For rated Btuh:		
From	To	Vertical
1,360	2,550	1/2
2,560	4,270	5/8
4,280	6,790	5/8 [†]
6,800	13,900	7/8
13,910	24,300	1-1/8
24,310	38,400	1-3/8
38,410	80,000	1-5/8
80,010	142,000	2-1/8

It may be necessary to make adjustments to compensate for special situations which cause the actual Btuh to differ from the rated Btuh of the cases.

All liquid line and suction line sizes are inches, refrigeration O.D. Subject to change without notice.

* If horizontal line size is smaller than specified vertical riser size, the smaller size may be used for both.

[†] 3/4 suction riser may be used to reduce pressure drop.

Liquid Correction Factors for Suction Vertical Riser Sizing Table - Use Minimum Liquid Temperature

Multiply rated Btuh by liquid correction factor before using the Suction Vertical Riser Sizing Table

Minimum Liquid Temperature:	40°F	50°F	60°F	70°F	80°F	90°F	100°F
Liquid Correction Factor:	0.84	0.88	0.94	1.00	1.07	1.16	1.27

CCR, 4/4/07

SP-0612-01, Rev B

REFRIGERATION

LOW TEMP (CONT.)

Figure 24: Refrigeration Line Sizing - Ice Cream

R-404 Line Sizing Tables for Zero Zone VZ Ice Cream Freezer (-16°F Evaporator Temperature)

Liquid Line Sizing - Electric Defrost*

Up to 50 equivalent feet

90°F Liquid, 2°F Pressure Drop[‡]

For rated Btuh:		
From	To	Liquid Line
0	7,090	1/4 [†]
7,100	14,600	5/16 [*]
14,610	26,500	3/8
26,510	62,800	1/2
62,810	117,000	5/8

Up to 100 equivalent feet

90°F Liquid, 2°F Pressure Drop[‡]

For rated Btuh:		
From	To	Liquid Line
0	4,830	1/4 [†]
4,840	9,930	5/16 [*]
9,940	18,200	3/8
18,210	43,100	1/2
43,110	80,900	5/8

Up to 150 equivalent feet

90°F Liquid, 2°F Pressure Drop[‡]

For rated Btuh:		
From	To	Liquid Line
0	3,850	1/4 [†]
3,860	7,930	5/16 [*]
7,940	14,500	3/8
14,510	34,500	1/2
34,510	64,800	5/8
64,810	108,000	7/8 [†]

Up to 200 equivalent feet

90°F Liquid, 2°F Pressure Drop[‡]

For rated Btuh:		
From	To	Liquid Line
0	3,270	1/4 [†]
3,280	6,750	5/16 [*]
6,760	12,400	3/8
12,410	29,400	1/2
29,410	55,400	5/8
55,410	92,100	7/8 [†]

* For hot gas defrost, use a liquid line one size larger than shown.

[‡] For 1°F pressure drop, multiply rated Btuh by 1.45 before using the Liquid Line Sizing Table.

^{*} Larger liquid line size may be used (such as 3/8), if preferred.

[†] 3/4 liquid line may be used to reduce cost.

Liquid Correction Factors for Liquid Line Sizing Table - Use Maximum Liquid Temperature

For maximum liquid temperatures other than 90°F, multiply rated Btuh by liquid correction factor before using the Liquid Line Sizing Table

Maximum Liquid Temperature:	40°F	50°F	60°F	70°F	80°F	90°F	100°F	110°F	120°F
Liquid Correction Factor:	0.95	0.94	0.94	0.95	0.97	1.00	1.05	1.12	1.23

Suction Horizontal Line Sizing

Up to 50 equivalent feet

90°F Liquid, 2°F Pressure Drop[‡]

For rated Btuh:		
From	To	Horizontal
0	1,420	3/8 ^{**}
1,430	3,360	1/2 ^{**}
3,370	6,300	5/8 ^{**}
6,310	10,500	7/8 [†]
10,510	16,600	7/8
16,610	33,600	1-1/8
33,610	58,400	1-3/8
58,410	92,300	1-5/8

Up to 100 equivalent feet

90°F Liquid, 2°F Pressure Drop[‡]

For rated Btuh:		
From	To	Horizontal
0	970	3/8 ^{**}
980	2,290	1/2 ^{**}
2,300	4,320	5/8 ^{**}
4,330	7,180	7/8 [†]
7,190	11,400	7/8
11,410	23,100	1-1/8
23,110	40,300	1-3/8
40,310	63,700	1-5/8
63,710	132,000	2-1/8

Up to 150 equivalent feet

90°F Liquid, 2°F Pressure Drop[‡]

For rated Btuh:		
From	To	Horizontal
0	770	3/8 ^{**}
780	1,840	1/2 ^{**}
1,850	3,450	5/8 ^{**}
3,460	5,750	7/8 [†]
5,760	9,120	7/8
9,130	18,600	1-1/8
18,610	32,400	1-3/8
32,410	51,200	1-5/8
51,210	107,000	2-1/8

Up to 200 equivalent feet

90°F Liquid, 2°F Pressure Drop[‡]

For rated Btuh:		
From	To	Horizontal
0	660	3/8 ^{**}
670	1,560	1/2 ^{**}
1,570	2,950	5/8 ^{**}
2,960	4,910	7/8 [†]
4,920	7,790	7/8
7,800	15,900	1-1/8
15,910	27,700	1-3/8
27,710	43,800	1-5/8
43,810	91,000	2-1/8

[‡] For 1°F pressure drop, multiply rated BTU by 1.44 before using the Suction Horizontal Line Sizing Table.

^{**} Larger suction horizontal line size may be used, if preferred.

[†] 3/4 horizontal suction line may be used to reduce cost.

Liquid Correction Factors for Suction Horizontal Line Sizing Table - Use Maximum Liquid Temperature

For maximum liquid temperatures other than 90°F, multiply rated Btuh by liquid correction factor before using the Suction Horizontal Line Sizing Table

Maximum Liquid Temperature:	40°F	50°F	60°F	70°F	80°F	90°F	100°F	110°F	120°F
Liquid Correction Factor:	0.72	0.76	0.80	0.86	0.92	1.00	1.10	1.22	1.38

Suction Vertical Riser Sizing

Maximum Allowable Riser Size For Adequate Oil Return*

70°F Minimum Liquid Temperature, using 0.35 PSI Per 100 Feet (per 2006 ASHRAE Handbook - Refrigeration).

For rated Btuh:		
From	To	Vertical
1,210	2,280	1/2
2,290	3,810	5/8
3,820	6,050	5/8 [†]
6,060	12,400	7/8
12,410	21,600	1-1/8
21,610	34,300	1-3/8
34,310	71,300	1-5/8
71,310	127,000	2-1/8

It may be necessary to make adjustments to compensate for special situations which cause the actual Btuh to differ from the rated Btuh of the cases.

All liquid line and suction line sizes are inches, refrigeration O.D. Subject to change without notice.

* If horizontal line size is smaller than specified vertical riser size, the smaller size may be used for both.

[†] 3/4 suction riser may be used to reduce pressure drop.

Liquid Correction Factors for Suction Vertical Riser Sizing Table - Use Minimum Liquid Temperature

Multiply rated Btuh by liquid correction factor before using the Suction Vertical Riser Sizing Table

Minimum Liquid Temperature:	40°F	50°F	60°F	70°F	80°F	90°F	100°F
Liquid Correction Factor:	0.83	0.88	0.94	1.00	1.08	1.17	1.28

CCR, 3/29/07

SP-0612-02, Rev B

REFRIGERATION

MEDIUM TEMP

Figure 25: Refrigeration Line Sizing

R-404 Line Sizing Tables for Zero Zone RVCC Cooler (+28°F Evaporator Temperature)

Liquid Line Sizing

Up to 50 equivalent feet

90°F Liquid, 2°F Pressure Drop^Δ

For rated Btuh:		
From	To	Liquid Line
0	2,750	3/16"
2,760	8,050	1/4"
8,060	16,600	5/16"
16,610	30,100	3/8
30,110	71,200	1/2

Up to 100 equivalent feet

90°F Liquid, 2°F Pressure Drop^Δ

For rated Btuh:		
From	To	Liquid Line
0	1,870	3/16"
1,880	5,480	1/4"
5,490	11,300	5/16"
11,310	20,600	3/8
20,610	48,800	1/2
48,810	91,700	5/8

Up to 150 equivalent feet

90°F Liquid, 2°F Pressure Drop^Δ

For rated Btuh:		
From	To	Liquid Line
0	1,480	3/16"
1,490	4,360	1/4"
4,370	8,990	5/16"
9,000	16,500	3/8
16,510	39,100	1/2
39,110	73,500	5/8

Up to 200 equivalent feet

90°F Liquid, 2°F Pressure Drop^Δ

For rated Btuh:		
From	To	Liquid Line
0	1,260	3/16"
1,270	3,710	1/4"
3,720	7,660	5/16"
7,670	14,000	3/8
14,010	33,400	1/2
33,410	62,800	5/8

^Δ For 1°F pressure drop, multiply rated Btuh by 1.45 before using the Liquid Line Sizing Table.

[†] Larger liquid line size may be used (such as 3/8), if preferred.

Liquid Correction Factors for Liquid Line Sizing Table - Use Maximum Liquid Temperature

For maximum liquid temperatures other than 90°F, multiply rated Btuh by liquid correction factor before using the Liquid Line Sizing Table

Maximum Liquid Temperature:	40°F	50°F	60°F	70°F	80°F	90°F	100°F	110°F	120°F
Liquid Correction Factor:	0.98	0.97	0.96	0.97	0.98	1.00	1.04	1.09	1.17

Suction Horizontal Line Sizing

Up to 50 equivalent feet

90°F Liquid, 2°F Pressure Drop[‡]

For rated Btuh:		
From	To	Horizontal
0	1,970	5/16" ^{**}
1,980	3,580	3/8
3,590	8,460	1/2
8,470	15,900	5/8
15,910	26,300	7/8 [†]
26,310	41,600	7/8
41,610	84,000	1-1/8

Up to 100 equivalent feet

90°F Liquid, 2°F Pressure Drop[‡]

For rated Btuh:		
From	To	Horizontal
0	1,350	5/16" ^{**}
1,360	2,450	3/8
2,460	5,810	1/2
5,820	10,900	5/8
10,910	18,100	7/8 [†]
18,110	28,700	7/8
28,710	58,000	1-1/8

Up to 150 equivalent feet

90°F Liquid, 2°F Pressure Drop[‡]

For rated Btuh:		
From	To	Horizontal
0	1,080	5/16" ^{**}
1,090	1,960	3/8
1,970	4,650	1/2
4,660	8,740	5/8
8,750	14,600	7/8 [†]
14,610	23,100	7/8
23,110	46,700	1-1/8
46,710	81,300	1-3/8

Up to 200 equivalent feet

90°F Liquid, 2°F Pressure Drop[‡]

For rated Btuh:		
From	To	Horizontal
0	920	5/16" ^{**}
930	1,670	3/8
1,680	3,970	1/2
3,980	7,470	5/8
7,480	12,500	7/8 [†]
12,510	19,700	7/8
19,710	40,000	1-1/8
40,010	69,600	1-3/8

[‡] For 1°F pressure drop, multiply rated Btuh by 1.44 before using the Suction Horizontal Line Sizing Table.

^{**} Larger suction horizontal line size may be used, if preferred.

[†] 3/4 horizontal suction line may be used to reduce cost.

Liquid Correction Factors for Suction Horizontal Line Sizing Table - Use Maximum Liquid Temperature

For maximum liquid temperatures other than 90°F, multiply rated Btuh by liquid correction factor before using the Suction Horizontal Line Sizing Table

Maximum Liquid Temperature:	40°F	50°F	60°F	70°F	80°F	90°F	100°F	110°F	120°F
Liquid Correction Factor:	0.74	0.78	0.82	0.87	0.93	1.00	1.08	1.19	1.32

Suction Vertical Riser Sizing

Maximum Allowable Riser Size For Adequate Oil Return*

70°F Minimum Liquid Temperature, using 0.35 PSI Per 100 Feet (per 2006 ASHRAE Handbook - Refrigeration)

For rated Btuh:		
From	To	Vertical
480	880	5/16
890	2,090	3/8
2,100	3,950	1/2
3,960	6,590	5/8
6,600	10,500	5/8 [†]
10,510	21,300	7/8
21,310	37,300	1-1/8
37,310	59,100	1-3/8

It may be necessary to make adjustments to compensate for special situations which cause the actual Btuh to differ from the rated Btuh of the cases.

All liquid line and suction line sizes are inches, refrigeration O.D. Subject to change without notice.

* If horizontal line size is smaller than specified vertical riser size, the smaller size may be used for both.

[†] 3/4 suction riser may be used to reduce pressure drop.

Liquid Correction Factors for Suction Vertical Riser Sizing Table - Use Minimum Liquid Temperature

Multiply rated Btuh by liquid correction factor before using the Suction Vertical Riser Sizing Table

Minimum Liquid Temperature:	40°F	50°F	60°F	70°F	80°F	90°F	100°F
Liquid Correction Factor:	0.85	0.89	0.94	1.00	1.07	1.15	1.24

CCR, 10/3/07

SP-0612-11, Rev B

ELECTRICAL

GENERAL



Caution!

DISCONNECT POWER TO THE CASE BEFORE SERVICING ELECTRICAL COMPONENTS TO AVOID PERSONAL INJURY AND DAMAGE TO THE UNIT.

Figure 26 on page 32 for 30" and 24" door cases shows the typical wiring diagram for a low temperature case equipped with electric defrost. **Figure 27 on page 33** shows the typical wiring diagram for a low temperature case equipped with hot gas defrost. **Figure 30 on page 36** shows the typical wiring diagram for a medium temperature case. Each case is provided with a wiring diagram located in the electric box that shows the exact wiring of the case.

There are many control options available for multiple case defrost systems. Wiring diagrams and instructions can be obtained by contacting Zero Zone's Service Department.

External wiring should be sized according to the amperage rating stamped on the serial plate. The serial plate is located on the ceiling inside the left-hand door. Typical electrical values are shown on specification sheets for each of these cases in the bag attached to the case or are available at www.zero-zone.com. All internal wiring has been done at the factory. Cases with standard wiring have their control wires terminated in the electrical compartment located behind the kick rail at the right end of the case. A terminal block has been used to simplify field connections. An electrical box is mounted on the top of the unit for cases equipped with the optional top mount electrical connections.

All wiring must comply with the National Electrical Code and all local codes. After installation of the equipment, correct operation of the electrical circuits and controls and defrost operation and termination should be verified. All operating voltages and amperages should be measured and recorded.

OPTIONAL ELECTRICAL WIRING

Single Point Connection (Low Temp)

The "single point" connection system is designed to reduce the time required to install and wire one display case with one condensing unit. **Figure 28 on page 34** is a typical diagram for this system.

All of the display case controls, including the disconnect switch and the electronic case controls are installed behind the kickplate and prewired. The liquid line solenoid valve is installed in the liquid line and wired.

The power to operate the display case is connected at the case disconnect switch. The power to operate the condensing unit is connected in the condensing unit control panel. There are no interconnecting wires between the condensing unit and display case.

The controls operate the system as a pump down defrost. When the display case begins defrost, the liquid line solenoid valve, fans and anti-sweat heaters are de-energized. The defrost heaters are energized. The compressor continues to run and pumps down the coil. The compressor cycles off on its low-pressure control. If there is any residual liquid left in the coil, the suction line pressure will rise and the compressor may turn on and pump down the coil.

The liquid line solenoid is energized at the end of the defrost cycle and the defrost heaters are de-energized. The suction line pressure rises and the compressor starts. When the low temperature evaporator reaches operating temperature, the fans and anti-condensate door heaters are energized.

ELECTRICAL

GENERAL (CONT.)

Single Point Connection (Medium Temp)

The “single point” connection system is designed to reduce the time required to install and wire one display case with one condensing unit. **Figure 31 on page 37** is a typical diagram for this system.

All of the display case controls, including the disconnect switch and electronic case controls, are installed behind the kickplate and prewired. The liquid line solenoid valve is installed in the liquid line and wired.

The power to operate the display case is connected at the case disconnect switch. The power to operate the condensing unit is connected in the condensing unit control panel. There are no interconnecting wires between the condensing unit and display case.

The controls operate the system as a pump down defrost. When the display case begins defrost, the liquid line solenoid valve is de-energized. The fans and anti sweat heaters remain energized during defrost. The compressor continues to run and pumps down the coil. The compressor cycles off on its low-pressure control. If there is any residual liquid left in the coil, the suction line pressure will rise and the compressor may turn on and pump down the coil.

The liquid line solenoid is energized at the end of the defrost cycle. The suction line pressure rises and the compressor starts.

Master Satellite Connection (Low Temp)

The “master satellite” connection system allows one condensing unit to be connected to multiple cases. **Figure 29 on page 35** shows a typical diagram for this system.

All of the display case controls, including the disconnect switch, time clock, temperature control, and defrost temperature control, are installed behind the kickplate and prewired. The liquid line solenoid is prewired but is not installed in the liquid line.

The power to operate each display case is connected at each case’s disconnect switch. The power to operate condensing unit is connected at the condensing unit. There are no interconnecting wires between the condensing unit and display case. There are interconnecting wires that need to be connected between the cases. The liquid line solenoid valve needs to be installed in the common liquid line before the liquid is distributed to the cases.

The controls operate the system as a pump down defrost. When the display case begins defrost, the liquid line solenoid valve, fans and anti-sweat heaters are de-energized. The defrost heaters are energized. The compressor continues to run and pumps down the coil.

The master case contains the time clock. Interconnecting case wiring allows the master case to control the satellite cases. When defrost is initiated in the master case, it sends an electrical signal to each case to energize the defrost relay and initiate a defrost in all of the satellite cases. A second set of interconnecting wires is connected in series between each of the cases. Each case defrost heater is de-energized when the coil reaches the defrost termination temperature. An additional signal is relayed to the next case indicating that the termination temperature has been reached. When all of the cases have reached termination temperature, the defrost termination circuit is complete and the defrost is terminated.

The liquid line solenoid is energized at the end of the defrost cycle and the defrost heaters are de-energized. The suction line pressure rises and the compressor starts. When the evaporator reaches operating temperature, the delay thermostat (klixons) will close, energizing the fans and anti-sweat door heaters.

ELECTRICAL

GENERAL (CONT.)

Master Satellite Connection (Medium Temp)

The “master satellite” connection system allows one condensing unit to be connected to multiple cases. **Figure 32 on page 38** shows a typical diagram for this system.

All of the display case controls, including the disconnect switch, time clock, and temperature control, are installed behind the kickplate and prewired. The liquid line solenoid is prewired but is not installed in the liquid line.

The power to operate each display case is connected at each case’s disconnect switch. The power to operate the condensing unit is connected at the condensing unit. There are no interconnecting wires between the condensing unit and display case. There are interconnecting wires that need to be connected between the cases. The liquid line solenoid valve needs to be installed in the common liquid line before the liquid is distributed to the cases.

The controls operate the system as a pump down defrost. When the display case begins defrost, the liquid line solenoid valve is de-energized. The compressor continues to run and pumps down the coil.

The master case contains the time clock. Interconnecting case wiring allows the master case to control the satellite cases. When defrost is initiated in the master case, it sends an electrical signal to each case to initiate a defrost in all of the satellite cases. A second set of interconnecting wires is connected in series between each of the cases.

The liquid line solenoid is energized at the end of the defrost cycle. The suction line pressure rises and the compressor starts.

ELECTRICAL

LOW TEMP

Figure 26: Electric Defrost 30" & 24" Wiring

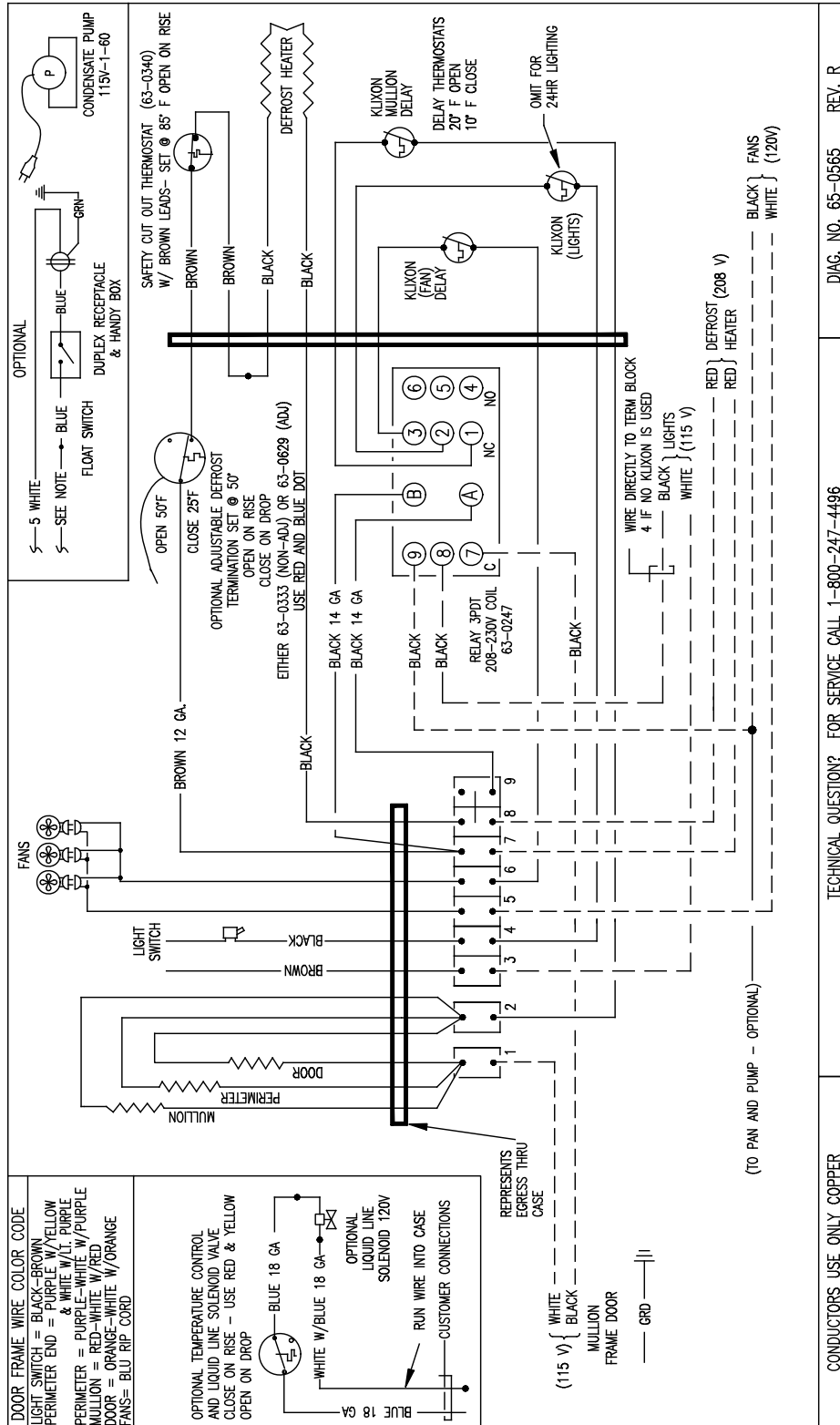

DIAG. NO. 65-0565 REV. R

TECHNICAL QUESTION? FOR SERVICE CALL 1-800-247-4496

CONDUCTORS USE ONLY COPPER

ELECTRICAL

LOW TEMP (CONT.)

Figure 27: Hot Gas Wiring

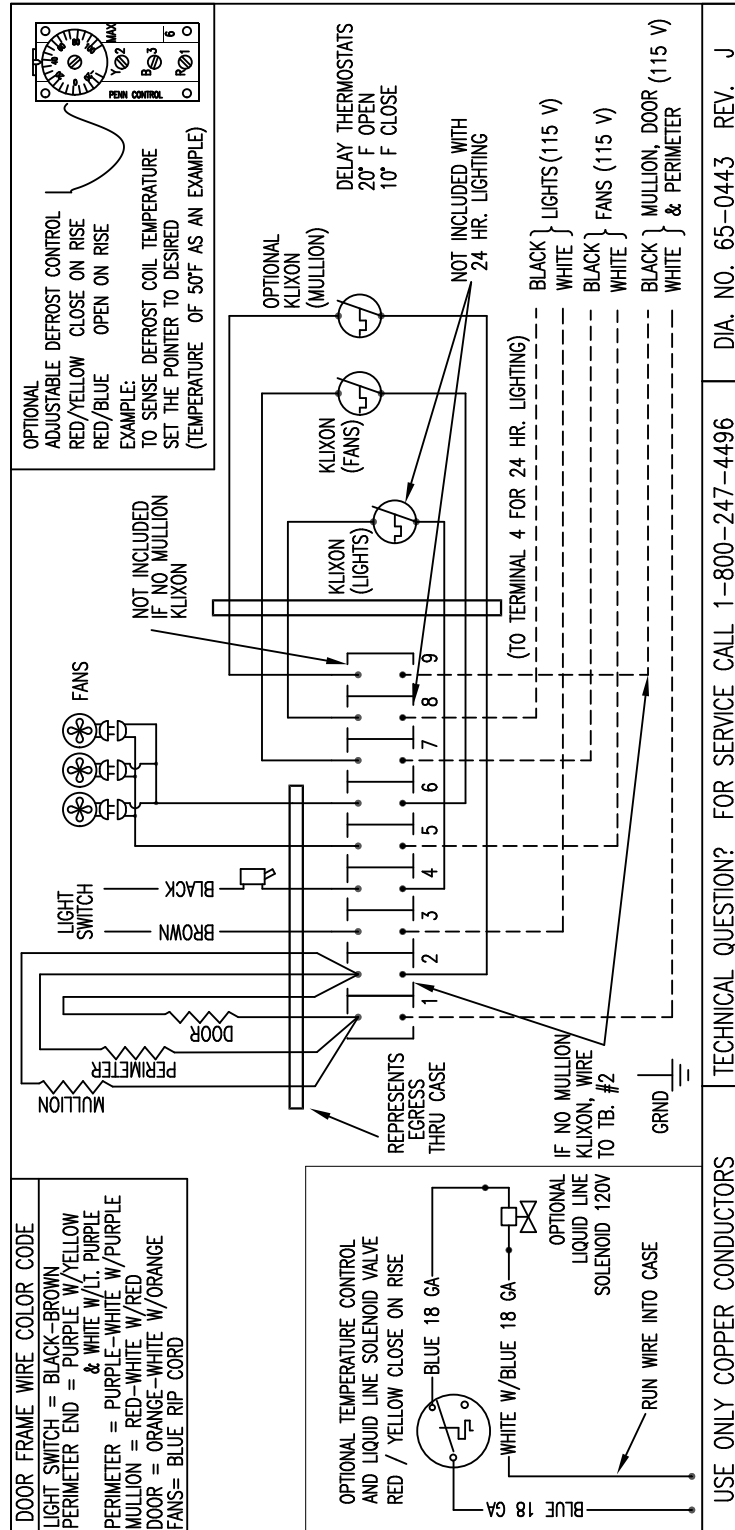

ELECTRICAL

LOW TEMP (CONT.)

Figure 29: Master Satellite Wiring

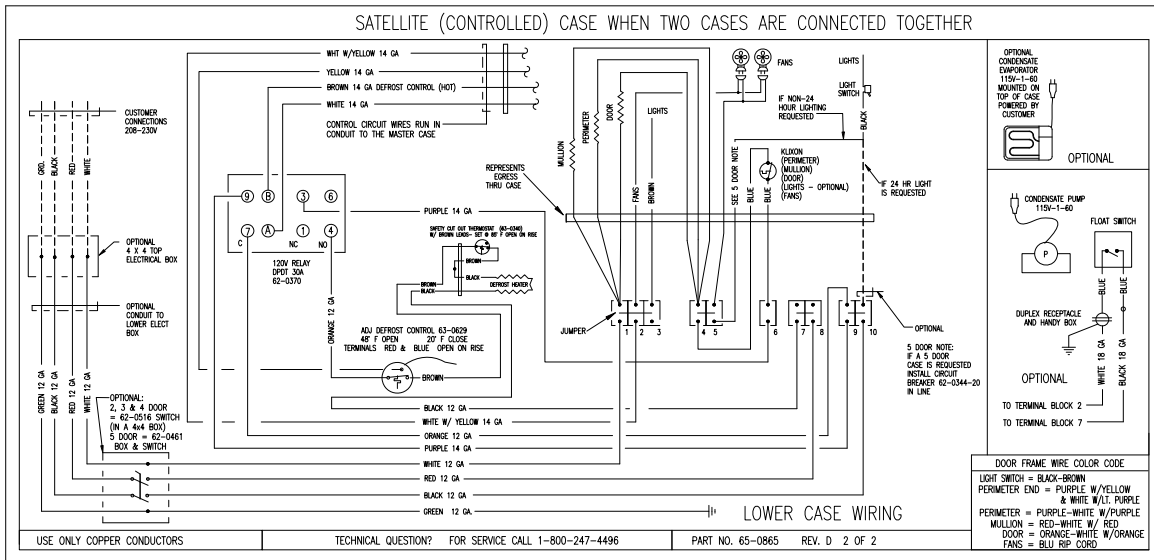
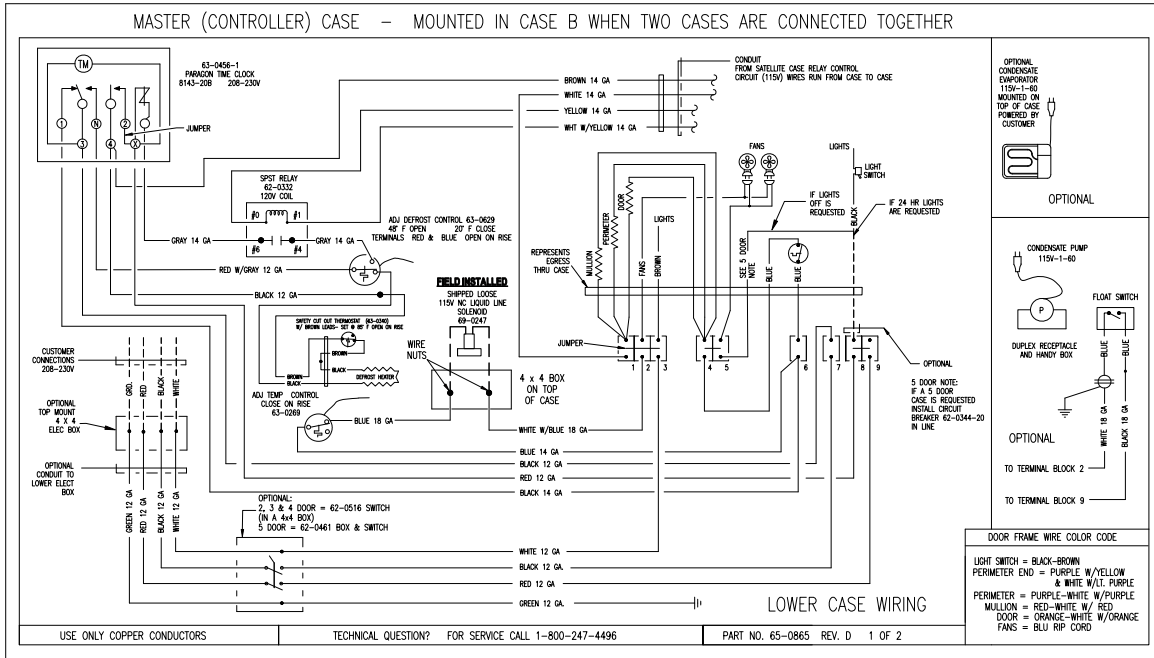

ELECTRICAL

MEDIUM TEMP (CONT.)

Figure 31: Single Point Wiring

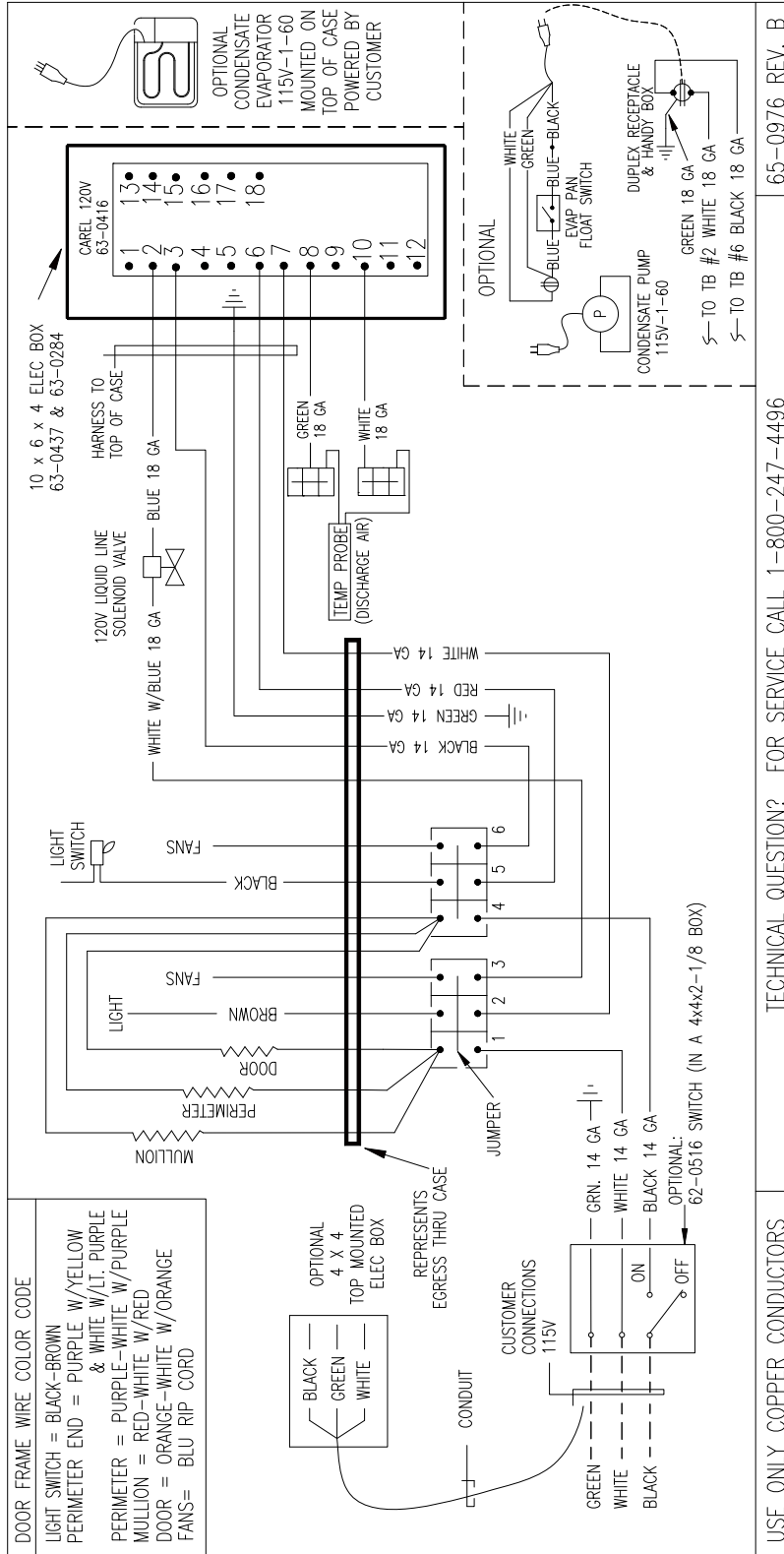

ELECTRICAL

MEDIUM TEMP (CONT.)

Figure 32: Master Satellite Wiring

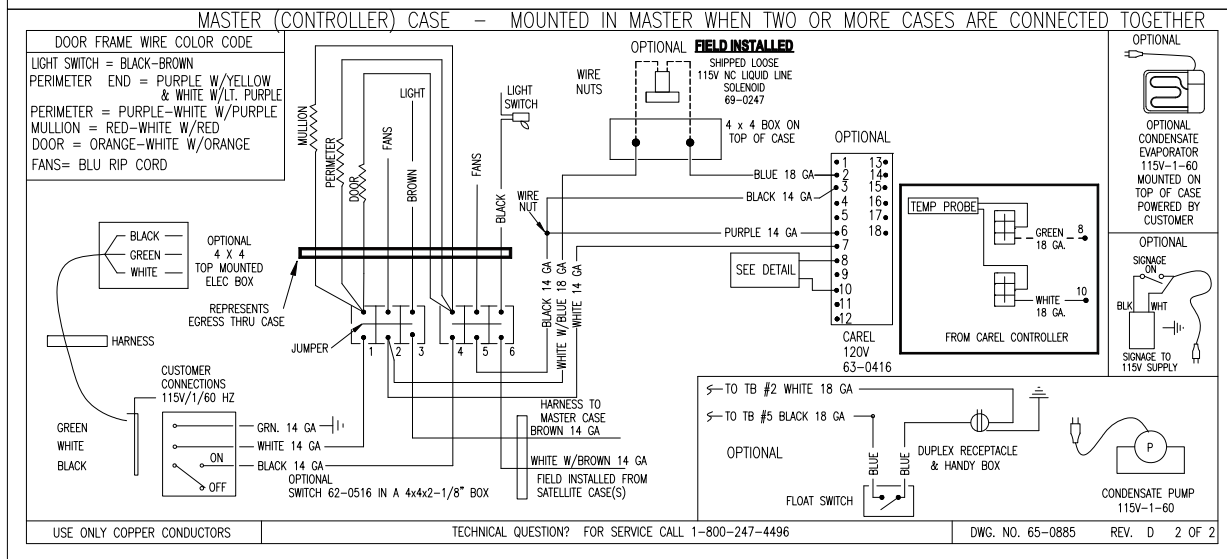
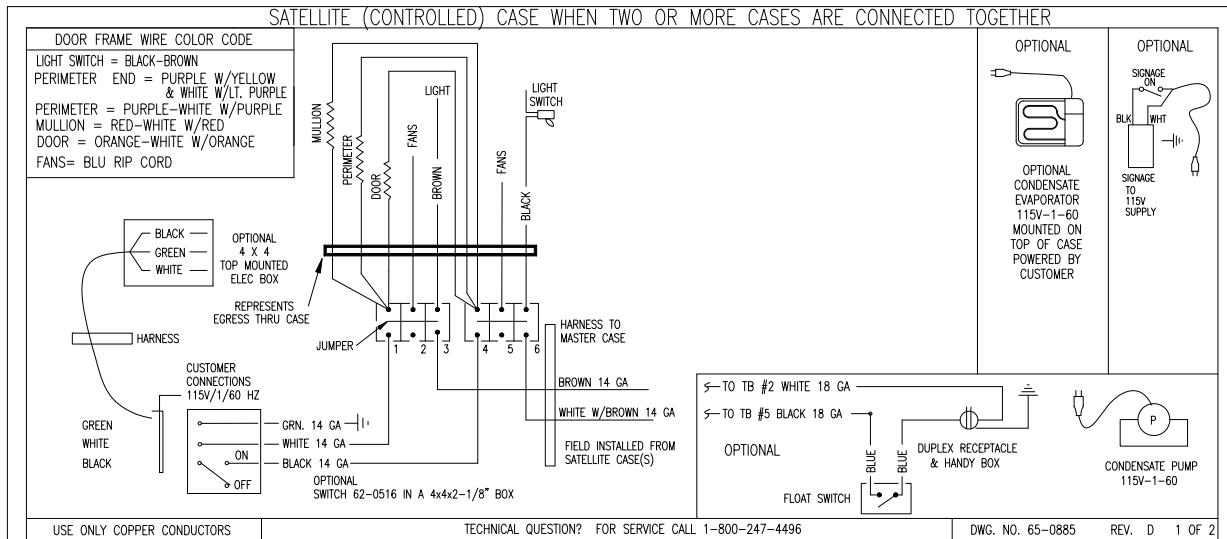

DEFROSTING

LOW TEMP

GENERAL

Periodic defrosting to keep the coil free of frost is accomplished automatically by a time clock used in conjunction with an electric or hot gas defrost.

For best results, temperature termination of defrost is strongly recommended on Zero Zone cases.

DEFROST SETTINGS AND CONTROLS

Electric Defrost

Frequency: One electric defrost per day is recommended.

Time of day: Nighttime defrosting is preferred to avoid periods of shopping or stocking.

Drip Time: Electric defrost does not require any drip time because Zero Zone provides a built-in fan delay thermostat.

Electric Defrost Fail-safe Times:

	ICE CREAM	FROZEN FOOD
VZ 30" Door	1/day at 45 mins	1/day at 45 mins
VZT2 30" Door	1/day at 55 mins	1/day at 55 mins
MZ 24" Door & WA	1/day at 54 mins	1/day at 54 mins

At ASHRAE test conditions and 208 volt defrost heater operation, the typical observed VZ 30" door defrost durations are 28 minutes for ice cream and 19 minutes for frozen food. At the same conditions, the typical observed VZT2 30" door defrost durations are 39 minutes for ice cream and 26 minutes for frozen food. MZ 24" and WA defrost durations are 43 minutes.

Preferred Termination: For optimal performance, Zero Zone recommends a temperature-terminated defrost, using a defrost termination thermostat or probe sensing the coil temperature.

The VZ and VZT2 30" door case has the probe located at the right-hand side of the coil in the center of the bottom row of tubes.

The MZ 24" door and WA case has the probe located at the right-hand side of the coil in the top row of tubes.

If the case is so equipped, the defrost termination temperature is 50°F. Zero Zone provides a defrost termination thermostat unless a control system defrost probe is requested.

Temperature termination based on coil temperature allows the length of defrost to vary depending on how much frost is on the coil and the defrost heater voltage. Coil frost is a function of shopping patterns, stocking habits, general door maintenance and ambient temperature and humidity. More frost requires a longer defrost. A lower defrost heater voltage extends the defrost period.

Alternate Termination: If it is not possible to terminate the defrost cycle based on a defrost termination thermostat or probe sensing the temperature at the coil, and the only available temperature probe is sensing the discharge air temperature, then the termination temperature should be set to 65°F, zero minutes drip time.

Zero Zone electric defrost freezers are delivered with the defrost thermostat open-on-rise contacts wired in series with the defrost heaters. Unless the installer rewires the defrost thermostat, the defrost heater is de-energized when defrosting is complete.

Zero Zone VZ and VZT2 30" door electric defrost freezers are also equipped with a high-limit, snap-disc thermostat that de-energizes the defrost heater if the coil temperature exceeds 85°F to provide a secondary safety termination.

Hot Gas Defrost

Frequency: One hot gas defrost per day is recommended.

Time of day: Nighttime defrosting is preferred to avoid periods of shopping or stocking.

Drip time: Hot gas defrost requires a 5 minute drip time.

Hot Gas Defrost Fail-safe Times:

	ICE CREAM	FROZEN FOOD
Hot Gas	1/day at 30 mins 5 min drip	1/day at 30 mins 5 min drip
Reduced Temperature Gas	1/day at 40 mins 5 min drip	1/day at 40 mins 5 min drip
MZ 24" Door & WA	1/day at 54 mins	1/day at 54 mins

Preferred Termination: For optimal performance, Zero Zone recommends a temperature-terminated defrost, using a defrost termination thermostat or probe attached to the dump line.

At ASHRAE test conditions, termination ranges from 12-22 minutes.

If the cases are so equipped, the defrost termination is 65°F at the dump line. Zero Zone provides a defrost termination thermostat unless a control system defrost probe is requested.

DEFROSTING

LOW TEMP (CONT.)

Electric Defrost Operation

The compressor stops when the defrost is initiated in a non-pump-down system. On pump-down systems, the liquid line solenoid will be de-energized when the defrost is initiated. The clock will energize the 208/230 volt defrost heater, and energize the normally closed 208/230 volt contactor or relay. This de-energizes the 115-volt fans, lights and anti-sweat heaters. If you don't have a light circuit limit thermostat, the lights will not de-energize.

After the defrost period, the compressor will operate. When the coil temperature reaches +5°F, the fan, light and anti-sweat heater limit thermostats (Klixons) will close, starting the fans, lights and anti-sweat heaters.

Gas Defrost Operation

Several types of gas defrost methods (using time-actuated, time-terminated or temperature-terminated defrost timers) can be used to defrost the evaporator.

The refrigeration system designer and installer are responsible for correct line sizing for effective gas defrost and liquid return from the freezers. Sizing and component selection depend on the type of defrost, size, and location of high side refrigeration system.

Zero Zone freezers equipped for gas defrost consist of a side port distributor and a TXV check valve for coil defrost, and a suction line check valve to bypass hot gas to the serpentine coil. The serpentine coil is attached to the bottom of the pan to ensure pan and drain defrost.

The timer starts the gas defrost cycle by energizing a solenoid, reversing valve, or directional valve. The gas is injected from the source into the suction line of the evaporator to be defrosted. The gas flows into the serpentine coil attached to the floor of the case and then into the evaporator. Condensed liquid leaves the evaporator through the side port distributor, through a check valve into the liquid line. **(Figure 33 and Figure 34 on page 41).**

General Notes

- The refrigeration technician should recheck coil condition after one week of retail operations to be certain that the frequency and duration of defrost is adequate for the particular store and locality. For example, if defrost voltage is below 200 volts, additional fail-safe time may be required.
- When using time terminated defrost, defrost termination thermostat should be wired in series with the defrost heater.
- Defrost termination thermostats may be wired in series for multiple evaporator installations.
- Defrost termination thermostats may be used as a digital input for electronic controllers.

Limit Thermostat

Each freezer has factory set limit thermostats (Klixons) attached to the return bends of the coil on the right end of the freezer to regulate the operation of the evaporator fans and anti-sweat door heaters. A limit thermostat is optional for the light circuit. When a limit thermostat is provided in the lighting circuit, the lights will be off during defrost.

IMPORTANT! OPERATION OF THE LIMIT THERMOSTATS CAUSES THE EVAPORATOR FANS, FREEZER LIGHTS, AND ANTI-SWEAT DOOR HEATERS TO REMAIN OFF UNTIL THE COMPRESSOR IS OPERATING AND THE COIL TEMPERATURE IS BROUGHT BELOW THE THERMOSTAT CUT-IN SETTING (+5°F). SUPERHEAT MUST BE SET CORRECTLY BY THE INSTALLING CONTRACTOR FOR PROPER THERMOSTAT OPERATION.

When the freezer first operates, the fans and lights may cycle off and on a few times until coil temperature is below +5°F. The superheat must be set for proper operation.

The 30" door models have a high limit thermostat installed on the coil return bend, wired in series with the defrost heaters. This thermostat opens when the temperature reaches 85°F.

DEFROSTING

LOW TEMP (CONT.)

ITEM #	PART NAME
1	COIL COVER
2	FAN
3	FAN HOUSING
4	COIL
5	CHECK VALVE
6	SERPENTINE
7	SLHX HEAT EXCHANGER
8	TXV VALVE
9	HAND VALVE (OPTIONAL)
10	DRIER (OPTIONAL)
11	CHECK VALVE
12	OPTIONAL DEFROST TERMINATION SOLENOID
13	HOT GAS CLIP
14	DEFROST TERMINATION PROBE LOCATION

Figure 33: Coil 30" Hot Gas

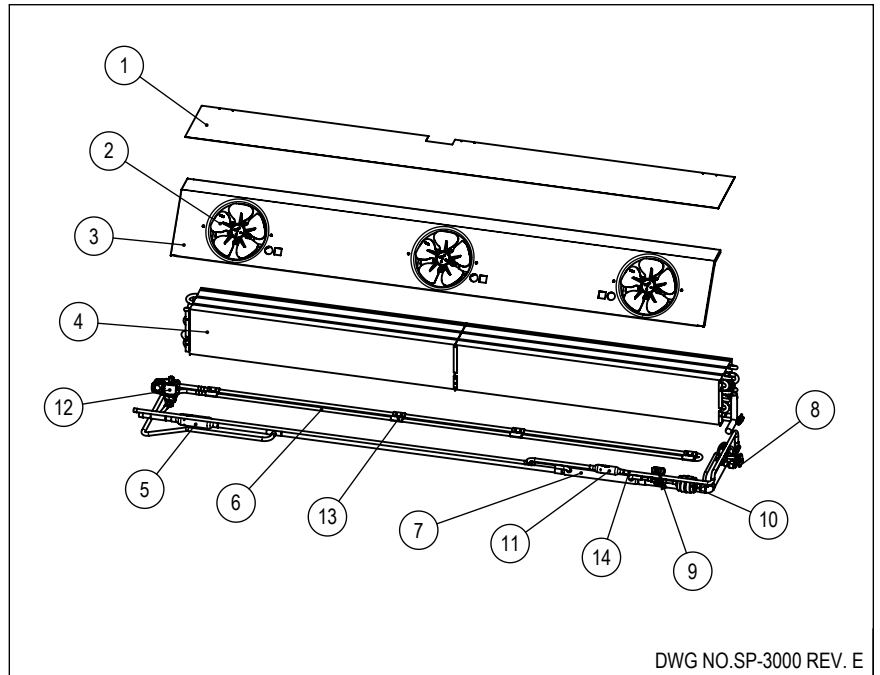

ITEM #	PART NAME
1	COIL COVER
2	FAN
3	FAN HOUSING
4	COIL
5	CHECK VALVE
6	SERPENTINE
7	SLHX HEAT EXCHANGER
8	TXV VALVE
9	HAND VALVE (OPTIONAL)
10	DRIER (OPTIONAL)
11	CHECK VALVE
12	OPTIONAL DEFROST TERMINATION SOLENOID
13	DEFROST TERMINATION PROBE LOCATION

Figure 34: Coil 24" Hot Gas

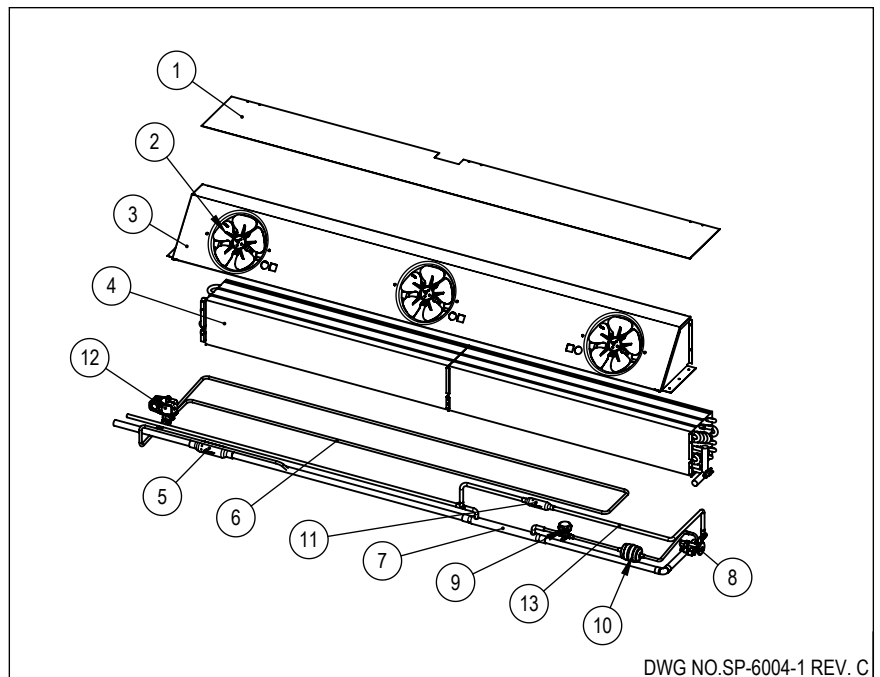

DEFROSTING

LOW TEMP (CONT.)

DEFROST HEATER ELEMENT

On 30" door cases, one half of the U-shape heater is located on the front of the coil and the other half is located on the rear of the coil (**Figure 35 on page 43**). On 24" door cases and wrap-around cases, the heater element is located under the coil (**Figure 33 on page 41**). The electric wire leads are connected in the junction box behind the front kick rail.

HEATER ELEMENT REMOVAL

Front and rear heater location (VZ and VZT2 30" door)

The U-shape defrost heater has one leg located on the front of the coil and one leg located on the rear of the coil. The front heater is located approximately 1" off the floor and the rear heater is approximately 2" off the floor. The heater is secured to the coil by a number of stainless steel heater retaining clips. The heater is fastened to the floor on the right-hand side of the coil. Remove fasteners holding the heater to the floor.

The U-shape defrost heater can be removed by first pulling the front leg of the retaining clip away from the coil and sliding the heater out from under the clip. The rear leg of the heater can then be removed by raising the retaining clips 2 inches at a time, working from right to left on the coil. Repeat this process until the retaining clips are free of the coil. The heater will slide up with the retaining clip.

Under coil location (MZ 24" and WA door).

To remove the defrost element, remove the coil covers. Lift the inner coil cover upward and tip the fan housing forward. This will expose the coil. Remove both fan housing end brackets and center coil supports, then slide out the complete heater pan assembly from under the coil. Slowly lift the heater pan assembly between the coil and fan housing, turning it on edge while lifting.

Heaters are installed in the reverse order of how they were removed.

DEFROSTING

LOW TEMP/MEDIUM TEMP

ITEM #	PART NAME
1	COIL COVER
2	FAN
3	LIQUID LINE
4	SUCTION LINE
5	FAN HOUSING
6	HEAT EXCHANGER
7	EXPANSION VALVE
*8	HEATING ELEMENT
*9	HEATER CLIP
10	DEFROST TERMINATION PROBE LOCATION

**Low Temp Only*

Figure 35: 30" Electric

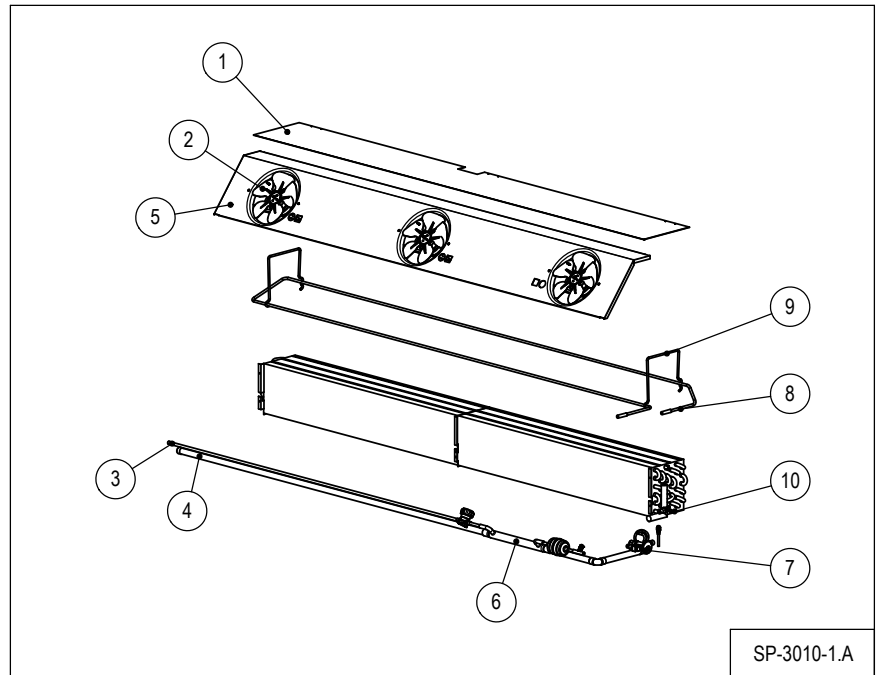

SP-3010-1.A

ITEM #	PART NAME
1	COIL COVER
2	FAN
3	LIQUID LINE
4	SUCTION LINE
5	FAN HOUSING
6	HEAT EXCHANGER
7	EXPANSION VALVE
*8	HEATER
*9	HEATER PAN
10	DEFROST TERMINATION PROBE LOCATION

**Low Temp Only*

Figure 36: 24" Electric

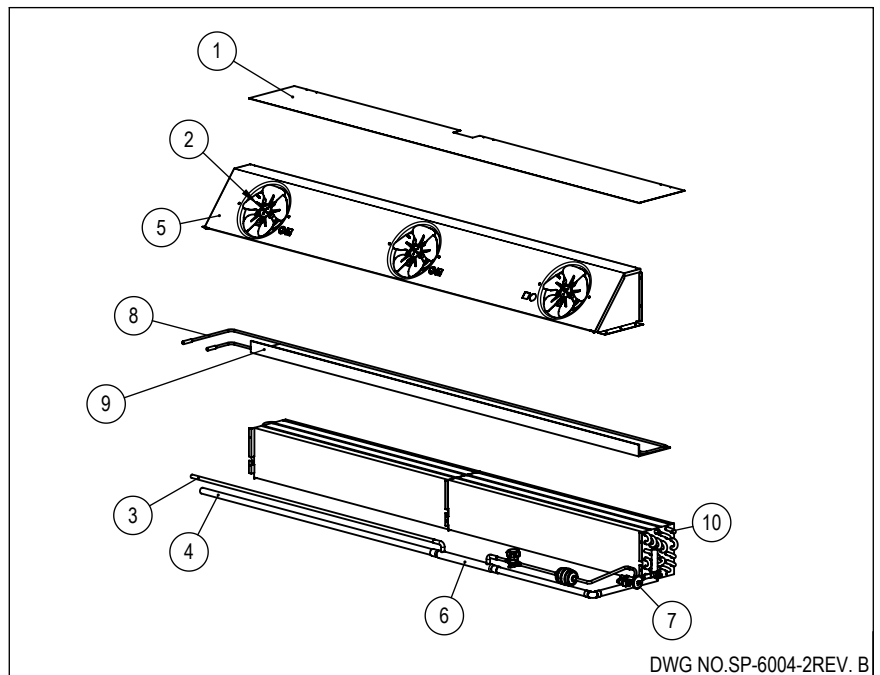

DWG NO.SP-6004-2REV. B

DEFROSTING

MEDIUM TEMP

GENERAL

Periodic defrosting to keep the coil free of frost is accomplished automatically by a time clock. Medium temperature cases generally operate at temperatures that allow for off-cycle defrost. Medium temperature cases that operated at colder temperatures for fresh meat products may use electric or hot gas defrost.

DEFROST SETTINGS AND CONTROLS

Off-Cycle Defrost

Frequency: Two off-cycle defrosts per day are recommended.

Duration: Generally defrost is terminated on time with the recommended setting of 30 minutes. If temperature termination is selected, the termination temperature is set for 45°F for discharge air and coil temperature. Stocking or shopping activities during defrost may result in premature defrost termination.

ELECTRIC AND HOT GAS DEFROST

Follow the setting recommendations found in the **Defrosting Low Temp** section.

DEFROST OPERATION

Off-Cycle

For off-cycle defrost, refrigeration to the unit is stopped either by stopping the compressor or closing the liquid line solenoid valve and allowing the compressor to pump down. During an off-cycle defrost, the fans, lights, and anti-sweat heaters remain on.

Electric and Hot Gas

For a description of these defrost types see the **Defrosting Low Temp** section.



For other technical support, please refer to
Zero Zone Installation and Operation Manuals
available on the Service page at:

WWW.ZERO-ZONE.COM

or contact the Zero Zone Service Department at:

800-247-4496

All specifications subject to change without notice.

©2013 Zero Zone, Inc.

