



ZERO ZONE

HYBRID™ MEDIUM & LOW TEMP DISPLAY CASE

Installation, Operation & Maintenance Manual

Compliant with 2012 DOE Regulations



**This manual is specific to the Zero Zone Hybrid™ display case.
For standard Zero Zone display case installation and operation, please refer
to the Zero Zone Medium & Low Temp Display Case Installation & Operation Manual.**

Table of Contents

ZERO ZONE WARRANTY	IV
▪ Limited Warranty	IV
▪ Extended Warranties	IV
▪ Length of Extended Warranty	IV
▪ Product Not Manufactured By The Seller	IV
▪ Limitation and Exclusion of Warranties	IV
PLANNING	1
DELIVERY	2
▪ Case Delivery Through 80" Door	2
SETTING THE CASE	3
▪ Contents Shipped Inside of Case	3
▪ Positioning Hat Channels.....	4
▪ Dividers Between Cases.....	5
MECHANICAL	6
▪ Once in Final Location	6
▪ Setting the Condensing Unit	7
▪ Quick Connect Fittings.....	8
▪ Coupling Insulation	9
ELECTRICAL/CONTROL	10
▪ Electrical Connections	10
▪ Carel Controller Sensor Wires	11
PLUMBING	12
▪ Case Drain Line to Floor Drain	12
TRIM OUT	13
▪ Installing Drain, Pump & Pan	13
ENCLOSED PUMP	15
▪ CB121LSUL Pump with Brackets	15
TRIM OUT	19
▪ Setting the Condensate Evaporation Pan.....	19
▪ Bumper & Kickplate	20
▪ Shroud Assembly	21
OPERATION	22
▪ Start-Up.....	22
▪ Carel Controller Standard Features.....	22
▪ Instructions for Setting the Time	22
▪ Turning the Lights On & Off	23
▪ Automatic Hold-Open Doors	24
MAINTENANCE	25
▪ Solid Shelf Installation & Removal	25
▪ Wire Shelf Installation & Removal.....	26
▪ Bottom Electrical Box Wire Colors (VZCH/VCCH Only)	27
▪ Instructions for Condensate Removal Systems with Condensate Evaporation Pan.....	28
▪ Refrigeration Cleaning & Maintenance	29
▪ Preventative Maintenance - Condensing Units & Evaporator Coils.....	29
▪ Carel Controller Programming Instructions.....	30
▪ Carel Controller Low Temp Codes	31
▪ Carel Controller Medium Temp Codes.....	32
▪ Carel Controller Basic Operations	33
▪ Silencing the Carel Temperature Alarm	34
▪ Conditions that Trigger the Carel Alarm	35
▪ Condensing Unit Pressure Switch Settings	36
OPTIONS	37
▪ Sound Attenuation Kit & Balloon Guard	37
▪ End Close-Off	38
▪ Fan Kit.....	38
▪ Shroud Frame Assembly.....	39
▪ Special Louvered Shroud Design	41
▪ Optional Disconnect Installation.....	46
MANAGER'S EMERGENCY GUIDE	47

ZERO ZONE WARRANTY

Limited Warranty

Zero Zone, Inc. (Seller) hereby warrants that any products manufactured by it and sold are warranted to be free from defects in material and workmanship, under normal use and service for its intended purpose, for a period of one (1) year from the date of original installation (not to exceed 15 months from the date of factory shipment). The obligation under this warranty shall be limited to repairing or exchanging any part, or parts, without charge, FOB Factory, and which is proven to the satisfaction of Zero Zone's service department to be defective. Zero Zone reserves the right to inspect the job site, installation, and reason for failure. This limited warranty does not cover labor, freight, or loss of food or product, including refrigerant loss. This warranty does not apply to motors, switches, controls, lamps, driers, fuses or other parts manufactured by others and purchased by the seller unless the manufacturer of these items warrants the same to the seller and then only to the extent of such manufacturer's warranty to the seller. Any products sold on an "AS IS" basis shall not be covered by this warranty.

Extended Warranties

In addition to the standard limited warranty, for further consideration, the Company will extend to the original purchaser, a limited extended warranty on the compressor only, following expiration of the standard warranty. The seller agrees to repair or exchange, at its option, or provide reimbursement for such exchange as directed, less any credit allowed for return of the original compressor, of a compressor of like or similar design and capacity, if it is shown to the satisfaction of Zero Zone that the compressor is inoperative due to defects in factory workmanship or material under normal use and services as outlined by Zero Zone in its "Service and Installation" instructions.

Length of Extended Warranty

Any compressor warranty may be extended for an additional four (4) years but such extension must be purchased prior to shipment to be effective. In those instances on manufactured systems where factory installed "Zero Zone Oil Management Systems" are purchased the original limited warranty shall be extended automatically to two (2) years total and purchased extended warranties shall be extended automatically for a total of six (6) years from the date of factory shipment. This warranty is only for the compressor and not for any other associated parts of the refrigeration system.

Product Not Manufactured By The Seller

The written Warranty, if any, provided by the manufacturer of any part of the refrigeration unit sold by Seller to Buyer, but not manufactured by Seller, is hereby assigned to the Buyer. However, Seller makes no representation or Warranty regarding the existence, validity or enforceability of any such written Warranty.

Limitation and Exclusion of Warranties

THE WARRANTIES SET FORTH HEREIN ARE EXCLUSIVE AND IN LIEU OF ALL OTHER WARRANTIES AND REMEDIES WHATSOEVER, INCLUDING, BUT NOT LIMITED TO, IMPLIED WARRANTIES OF MERCHANTABILITY AND/OR FITNESS FOR A PARTICULAR PURPOSE.

PLANNING

ENTRANCE & UNLOADING

- What is the height of the entryway that the case(s) will need to go through?
- Where will the case(s) be unloaded from the truck? Is there room for the case(s) to be unloaded from the truck?

CASE INSTALLATION & MOBILIZATION

- Are you able to move the case(s) inside store to final location?
- The condensing unit will produce some noise. Has this been taken into account when identifying the final location for these case(s)?
- Have you considered the door opening/swing and aisle width?

HEAT REJECTION

- Has the rejected heat from condensing unit(s) into store been considered?
- Do you have adequate room around the case(s) for the condensing unit to be able to reject heat? There should be a 30" minimum clearance between the top of shroud and the store ceiling.
 - Options/considerations if the clearance is less than the 30" minimum:
 - Add egg crates to the store ceiling panels
 - Add auxiliary fans to dissipate heat
 - Use louvered case shrouds
 - Use an alternate shroud height; Zero Zone Engineering must be contacted

ELECTRICAL

- Is there suitable voltage?
- Is the appropriate circuit breaker installed and available in the store power panel?
- Do you want/need an electrical disconnect at the case(s)?

PLUMBING

- Will you be using a floor drain? Can the proper slope to the drain be provided?
- Will you be using a pump with the Condensate Evaporation Pan system? This setup will add humidity to the store.

SEISMIC RESTRAINTS

- Does your permitting require there to be seismic restraints?

HIGH HUMIDITY

- Do you need an auxiliary fan system to provide air movement along the back and underneath the case(s)?
- Do you need louvered kickplates for air to be able to move underneath the case(s)?

PERMITTING

- The case(s) should be permitted as remote equipment.
- Always check with the local inspector to make sure your install follows all code requirements.

REMOTE MONITORING

- Remote monitoring is an option that is available for the case(s).

DELIVERY

Case Delivery Through 80" Door

OVERALL CASE DEPTH IS 40 1/8"



1. Remove bracket from back of case.

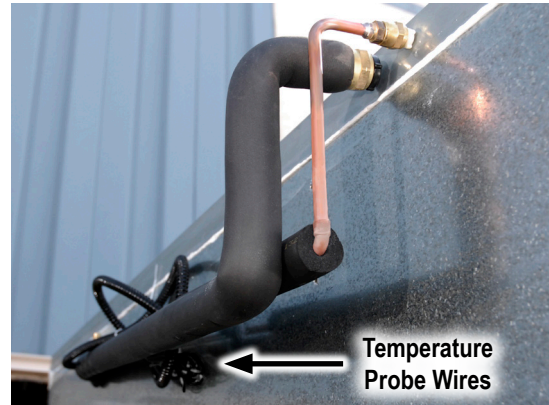

2. Pull quick connect lines away and down from case.
3. Reposition quick connect lines and reinstall bracket, once through doorway.



2 to 5-door cases are fork-liftable from either end of the case.
1-door cases are not fork-liftable through a standard doorway.

ATTENTION FORK TRUCK OPERATOR!

2-Door 24" Cases:

- Forks must extend from 20" to no more than 24" under the case from ends through bases.

2-Door 30" Or 3-Door 24" Standard Or Deep Cases:

- Forks must extend from 26" to no more than 30" under the case from ends through bases.

3-Door 30" Or 4-Door 24" Cases

- Use 48" long forks!
- Forks must extend from 39" to no more than 43" under the case from ends through bases.

4 & 5-Door 30" Or 6-Door 24" Cases

- Use 48" long forks!
- Forks must extend from 44" to no more than 47" under the case from ends through bases.

Note: Do not damage end of case with fork truck.

Do not place ("leave, store, or hold") case outdoors in direct sunlight or high ambient temperature.

SETTING THE CASE

Contents Shipped Inside of Case



- Pump and Pan Assembly
- Condensate Evaporation Pan



- Hat Channels with 1", 1.75" or 2.5" Bases

SETTING THE CASE

Positioning Hat Channels



- Position hat channels with tape up.
- For 3 and 4-door cases, (as shown above left), the center hat channel needs to be angled to rest on front and back base. Do not locate under drain hub!
- For 5-door cases (as shown above right) there are 4 hat channels - position as shown.
- In most instances, cases will require leveling by the use of shims. Refer to Display Case Installation & Operation Manual (Leveling Section).



SETTING THE CASE

Dividers Between Cases



Clear plexi dividers separate refrigeration circuits between same-temp cases.



Insulated dividers are provided between medium temp and low temp cases in lineups. Both types of dividers are factory-installed prior to shipping.

MECHANICAL

Once in Final Location

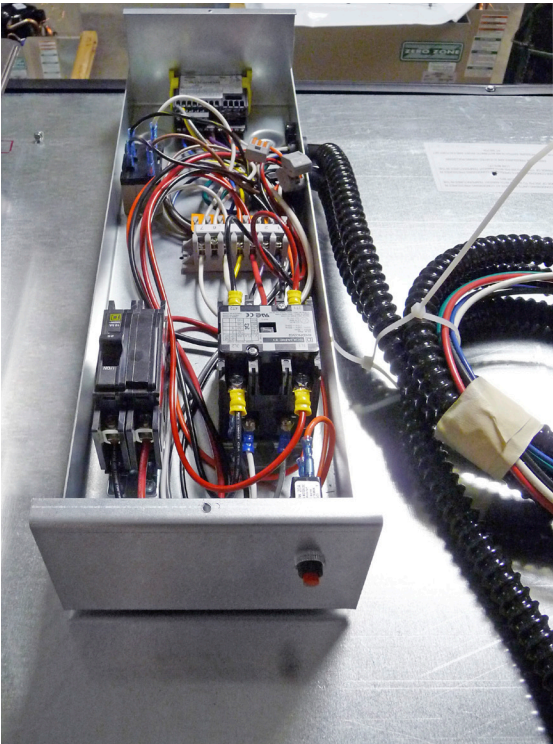
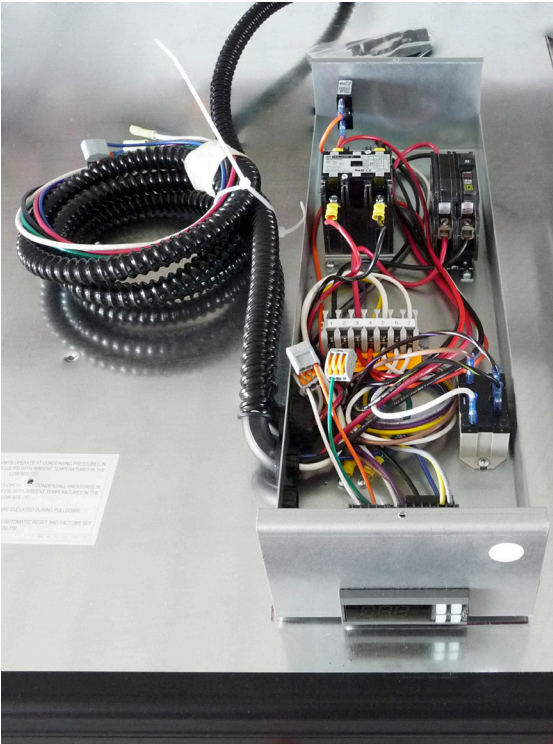

2 to 5-Door Shown

If electrical box was removed for entry, put back into position.

MECHANICAL

Setting the Condensing Unit



1. Locate quick connects on the back of the case.

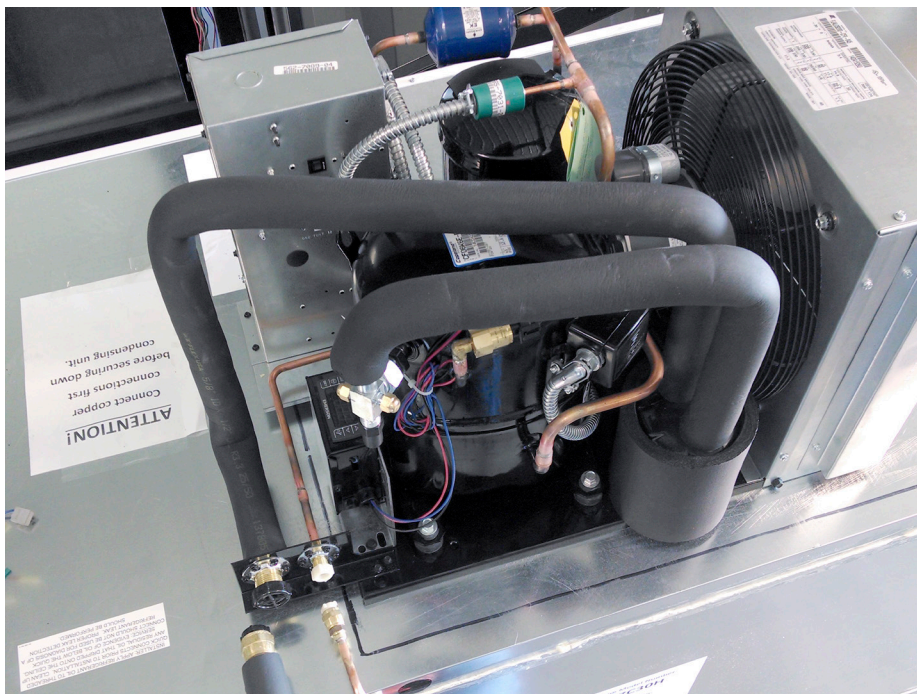

2. Place condensing unit with quick connects facing the back of the case.
3. Avoid scratching the front of the case.

MECHANICAL

Quick Connect Fittings

THIS IS THE MOST IMPORTANT PORTION OF THE HYBRID INSTALL

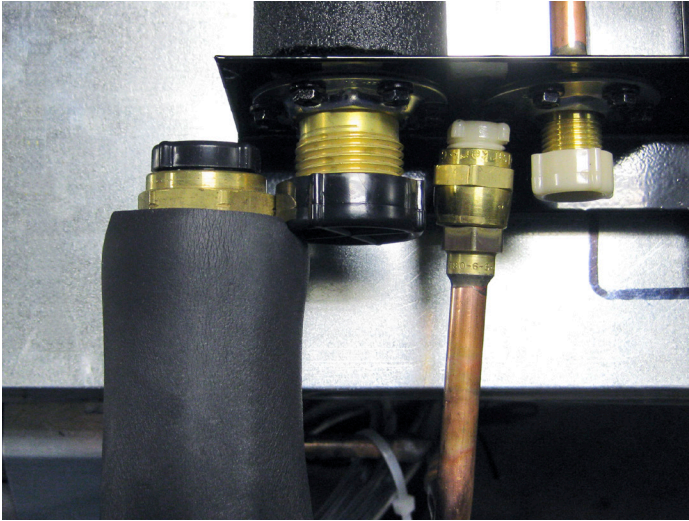

1. Align and pre-lubricate the couplers before connecting.
2. Start with hand tightening.
3. Tighten coupling connections with a wrench until seated or a definite resistance is felt. Mark a line on the swivel nut and unit. Using the line as a guide, tighten an additional quarter turn. (Sealing does not occur until no threads are visible.)
4. After all connections are made, check the couplings for leaks.

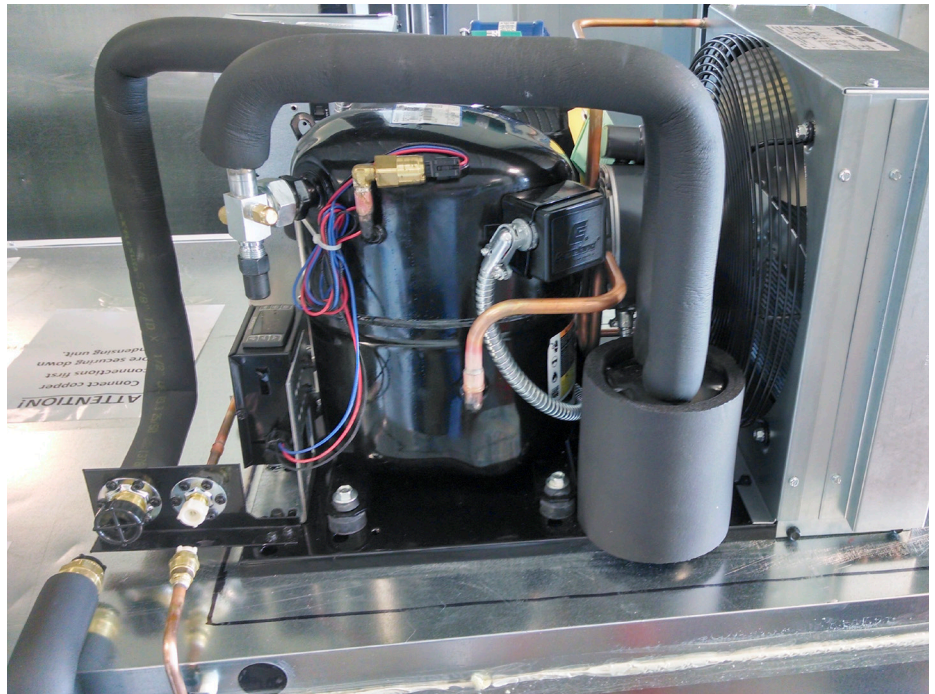

Wrench Size	Quick Connect Size	Torque Values
13/16"	3/8"	10-12 ft./lbs.
1 - 5/16"	1/2"	35-45 ft./lbs.
1 - 5/16"	5/8"	35-45 ft./lbs.

MECHANICAL

Coupling Insulation

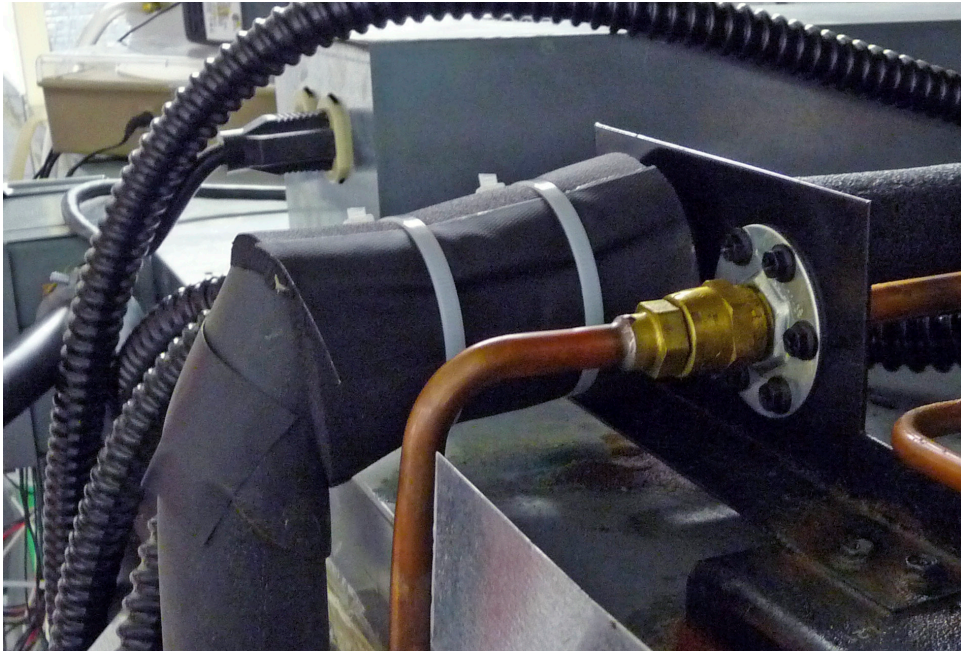
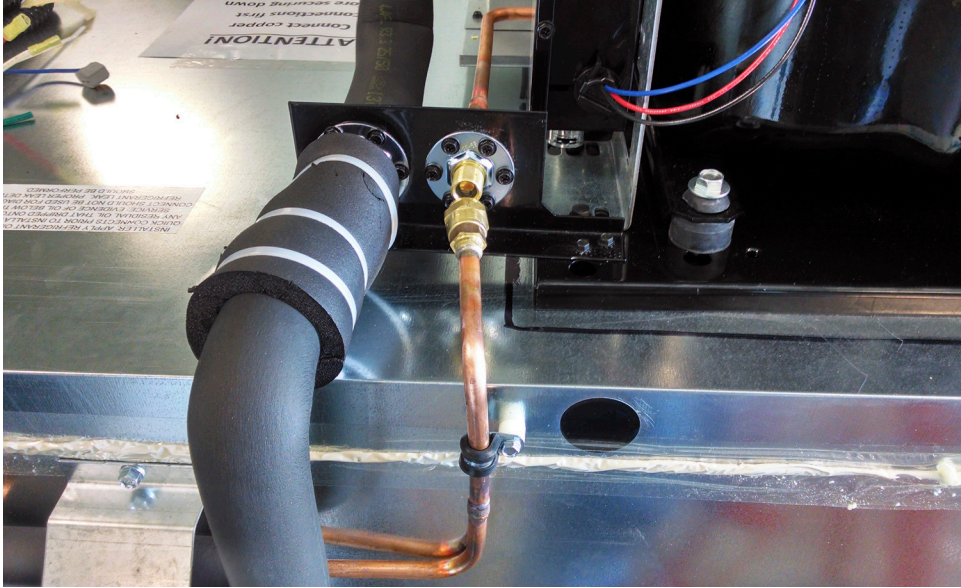

One pre-cut 4" piece of split insulation (supplied) will be required on each freezer suction side quick connect coupling as shown. Wire ties will also be provided.

ELECTRICAL/CONTROL

Electrical Connections

Cooler Electrical Box

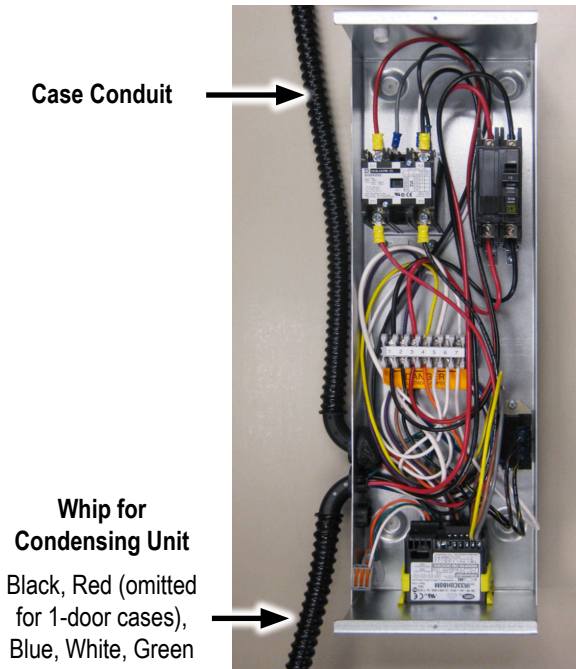

Freezer Electrical Box

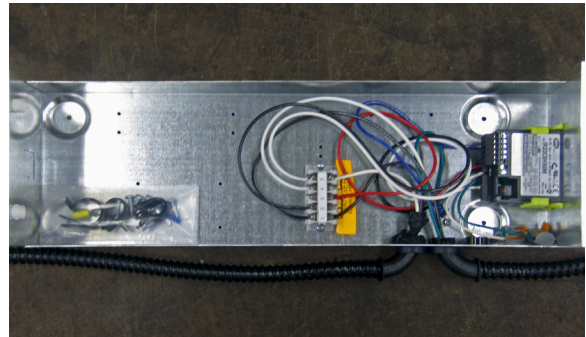

- Case power (top electrical box) brought from condensing unit electrical box.
- 2-5 door cases receive 208V 4-wire service; 115/208V-1PH-60HZ; red and black power, white neutral, green ground.
- 1-door cases receive 115V 3-wire service; 115V-1PH-60HZ; black power, white neutral, green ground.
- DO NOT ENERGIZE POWER UNTIL ALL COVERS ARE ON ALL ELECTRICAL BOXES.

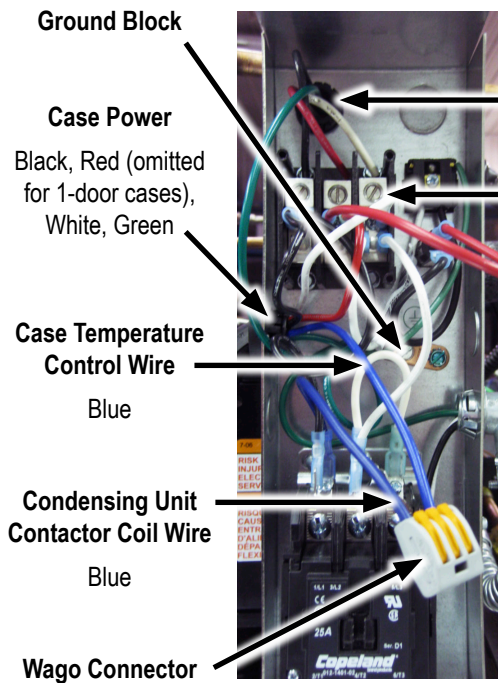

Condensing Unit Electrical Box - Small

Customer Power
Black, Red (omitted for 1-door cases and all coolers), White, Green

Distribution Block

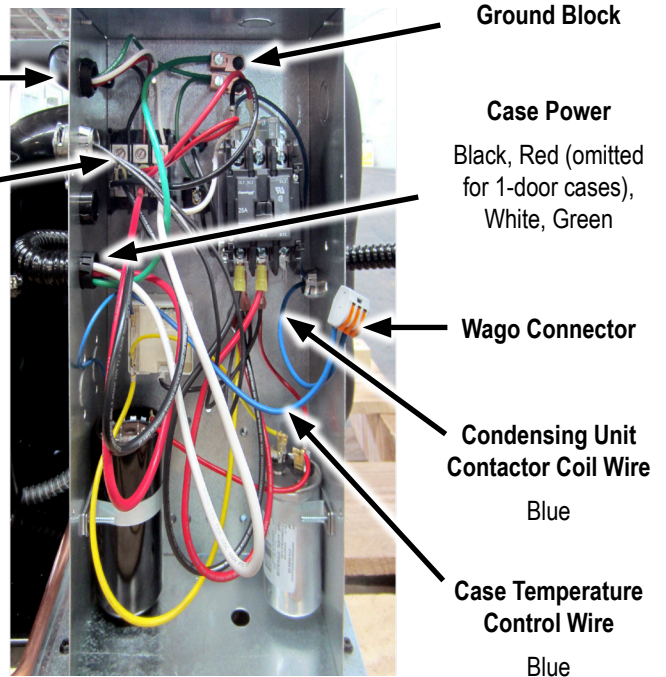

Condensing Unit Electrical Box - Large

See specific wiring diagrams shipped with your case.

ELECTRICAL/CONTROL

Carel Controller Sensor Wires

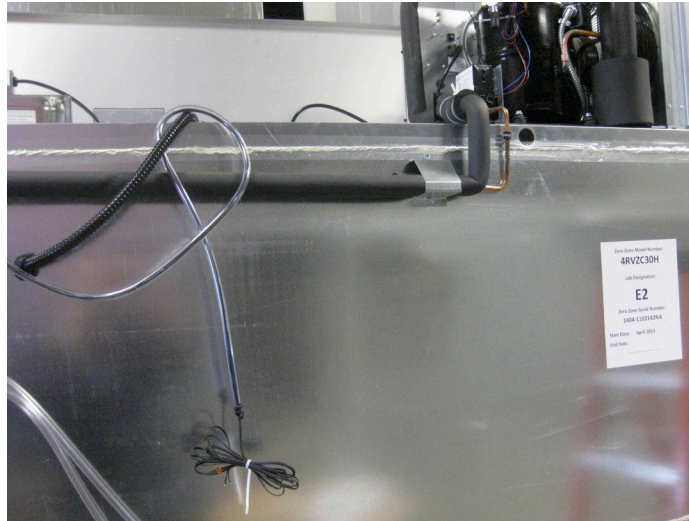

- Sensor wires are found on back of the case.
- Temperature (Discharge Air) probe located in false ceiling
- Evap (Defrost Term) probe located in coil.
- One sensor bulb is factory installed in medium temp case. Probe wires labeled Green & White for Temperature (Discharge Air).
- Two sensor bulbs are factory installed in low temp case. Probe wires labeled Green & White for Temperature (Discharge Air). Probe wires labeled Orange & White for Evap (Defrost Term).



Medium Temp

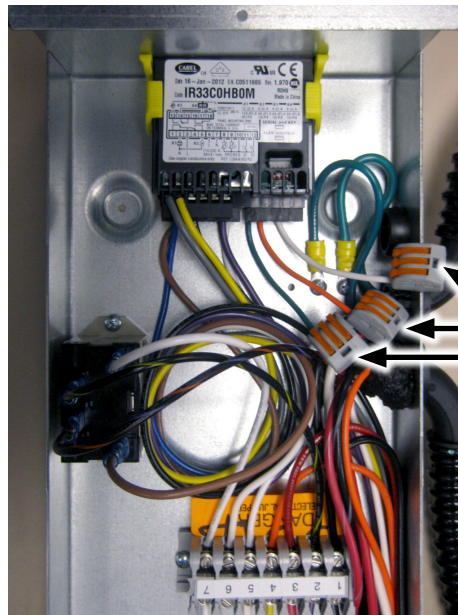

**Connect Sensor Wires
to Wago Connectors**

(match label color
to wire color)

Low Temp

PLUMBING

Case Drain Line to Floor Drain

(If Applicable)

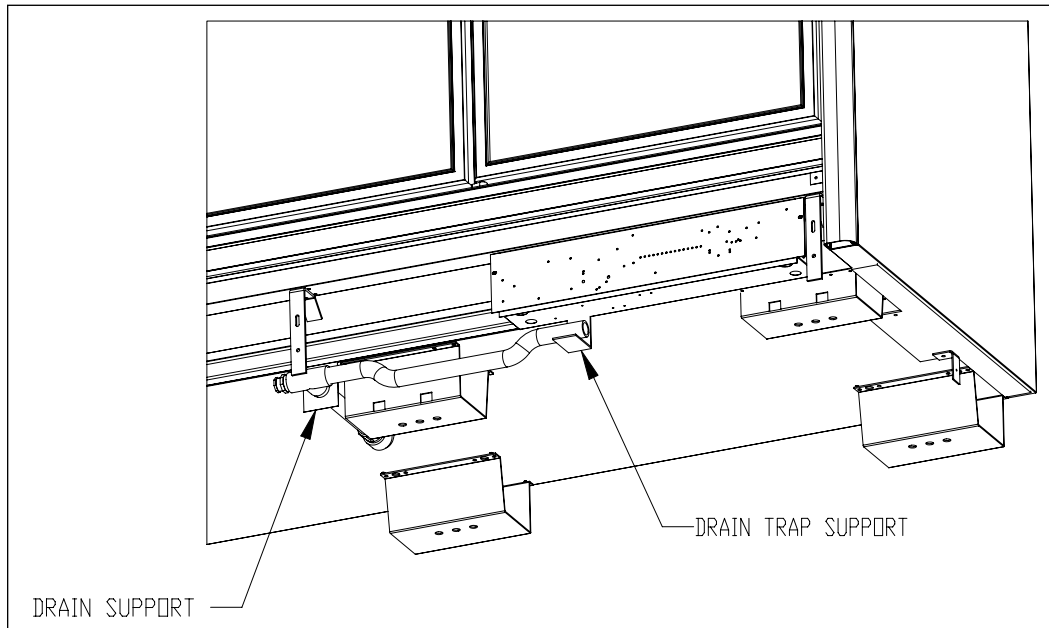

DRAIN LINE

The drain is located at the center of the case in the floor pan. The drain can be reached by removing the center coil covers and then removing a fan motor. The 1" PVC drain outlet is located at the center front of the case behind the kickplate.

Install the tee to the outlet pipe and a drain trap to the tee. Plug the open end of the tee using the clean-out plug supplied with the drain trap kit. The drain line must be pitched away from the case. The tee, drain trap, and plug are supplied with the case. The factory installs a drain support at the front of the case on all 30" door cases. We supply a trap support that is field mounted to the case. The drain trap must be level. The drain trap should be primed with water after installation.

Note (if applicable): Typically Hybrid cases are equipped with a condensate collection and removal system which includes a collection pan, pump, float switch, condensate evaporation pan with heater element, and connecting tubing.

TRIM OUT

Installing Drain, Pump & Pan

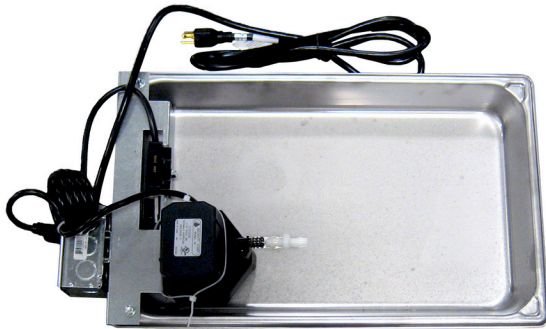

Drain Pan Assembly 2 to 5-Door



Drain Trap Assembly

1. Place the drain pan assembly as shown (Fig. 1).
2. Glue drain-trap assembly to drain. Attach drain assembly to case with screws provided (Fig. 2), except on 1-door which comes pre-attached.
3. Install PVC drain-trap extension/stop (Fig. 3).
4. Do not glue this component, but use the screw provided. This will allow the extension to be removed should the drain pan need cleaning or service (Fig. 4).
5. Finished assembly 2 to 5-door VZCH/VCCH (Fig. 5).
6. Finished assembly 1-door VZCH/VCCH (Fig. 6).
7. Finished assembly 2 to 6-door VLCH/VMCH (Fig. 7).
8. Attach PVC tubing to check valve and run to Condensate Evaporation Pan.
9. Test to confirm pump and float switch are operating properly.

TRIM OUT

Installing Drain, Pump & Pan

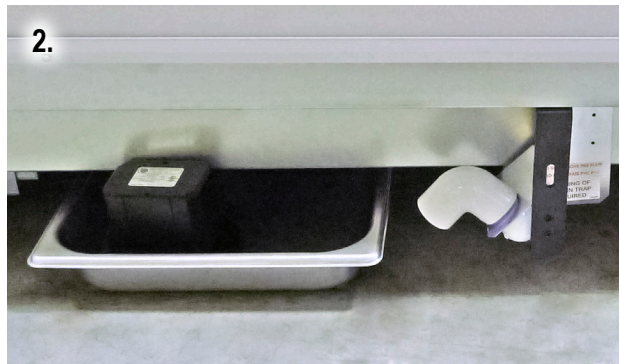
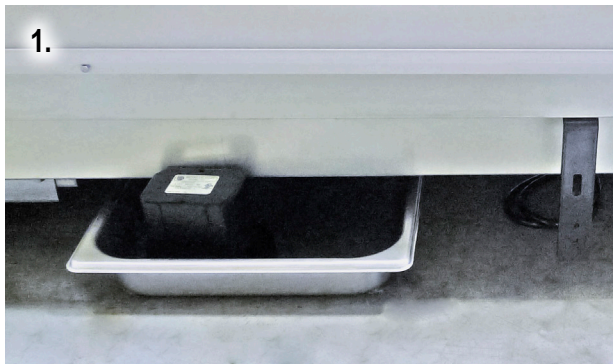

ENCLOSED PUMP

CB121LSUL Pump with Brackets



CB121LSUL Pump



Pump Kit

INSTALLATION INSTRUCTIONS

1. If case is shipped with 1.75" bases, then case lateral and support brackets will be shipped inside case. Prime and glue case lateral to elbow underneath case. Fasten bracket to front of foamed floor.



ENCLOSED PUMP

CB121LSUL Pump with Brackets

2. Place clear vinyl tube (from pump kit) over inlet to pump tank. Fasten into place using hose clamp (provided in pump kit).



ENCLOSED PUMP

CB121LSUL Pump with Brackets

3. Prime and glue PVC elbow to case drain lateral. PVC elbow needs to be angled downward. On 4 and 5-door cases, the pump should be installed to the right of the case lateral. On 1, 2, and 3-door cases, the pump should be installed to the left of the case lateral. On 1-door cases, the clear vinyl tubing will need to be cut to fit.

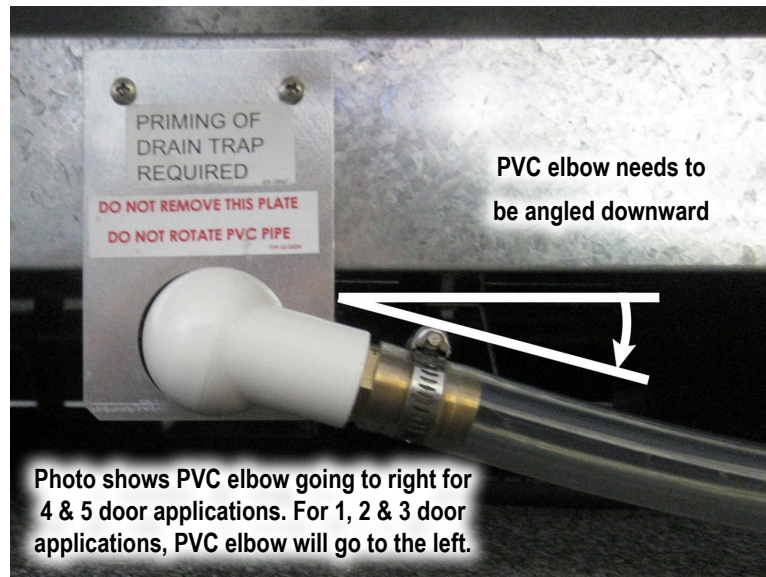

4. Install pump brackets into holes in the foamed floor. Install the pump onto the pump brackets. Pump will hang on the brackets via the hooks that are molded into the pump tank. Brackets are used to lift pump off the ground. This is to allow the kickplate flange to be underneath pump (preventing the pump from being tilted if hit by the kickplate flange).

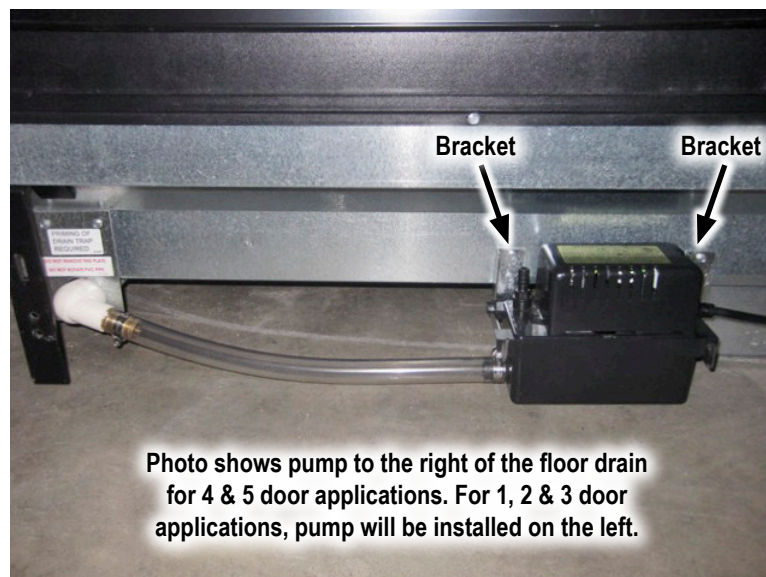

ENCLOSED PUMP

CB121LSUL Pump with Brackets

5. Attach discharge line to pump outlet.



6. Plug pump into outlet receptacle.



7. Prime pump. Note that you will see the water level in the clear tube.

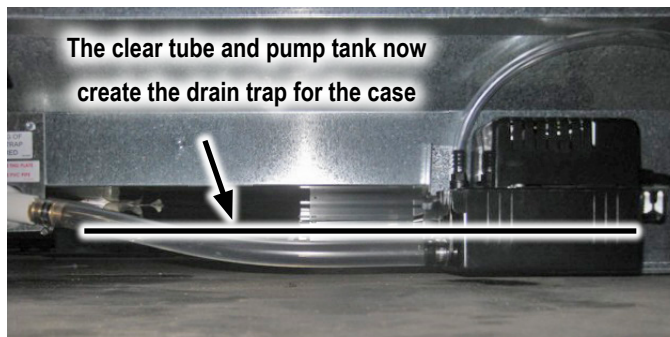

TRIM OUT

Setting the Condensate Evaporation Pan

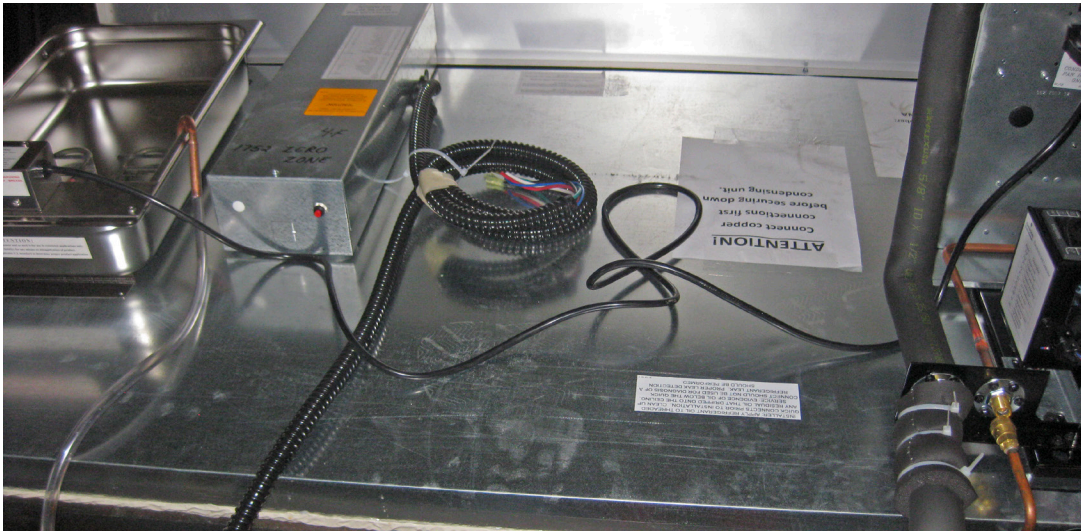

1. Place the Condensate Evaporation Pan on top of the case.
2. Move drain line(s) from the back to the top of the case and hang U copper drain line over the edge of the pan.
(Optional return line not shown.)
3. Plug into rear of condensing unit electrical box.

TRIM OUT

Bumper & Kickplate



Install Tinnerman clip to each bumper support (over the round hole).

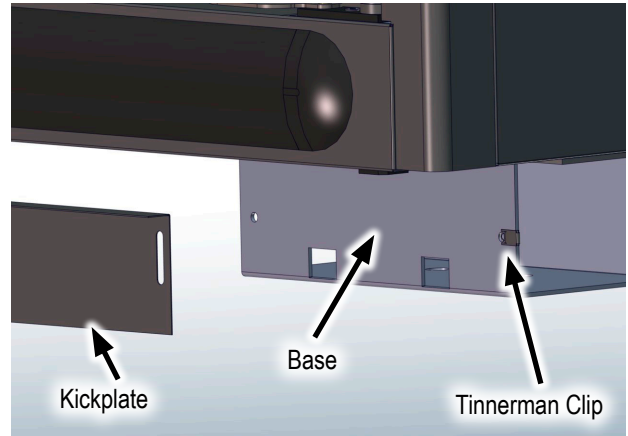
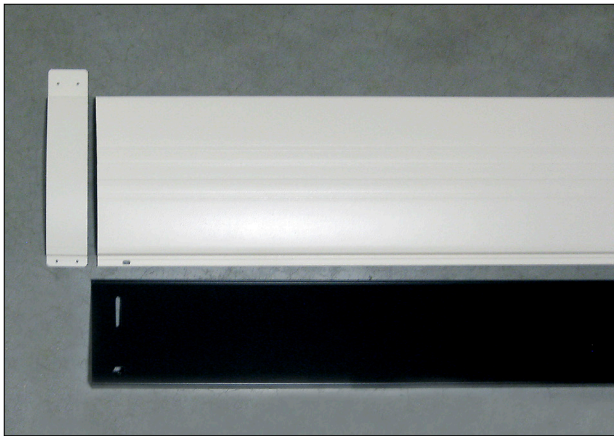

For VMC cases, Tinnerman clip is installed onto the base.

For case-to-case connection, align both bumpers and splice plate before fastening.

TRIM OUT

Shroud Assembly

FRONT SHROUD TO SIDE SHROUD ORIENTATION AND FASTENING

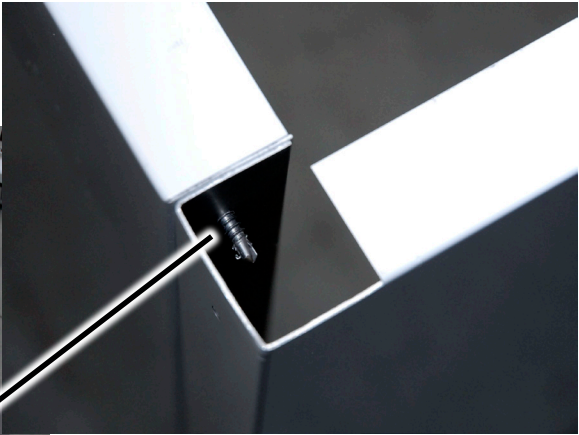

Front View

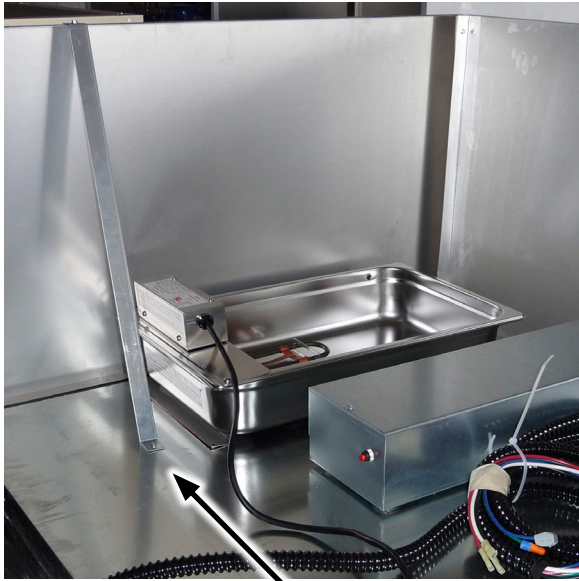

Side Shroud Brackets
One at each shroud side.

Back View

Front Shroud Brackets
None needed on 2-door,
use one on 3 & 4-door,
and use two on 5-door.



OPERATION

Start-Up

- Turn on the case by turning on the store circuit breaker or optional case disconnect.
- There will be a slight delay before the compressor starts.
- Set the time clock on the controller.
- The case fans can cycle for as long as 30 minutes (unless the case goes into defrost).
- The condensing unit will run continuously for as long as 12 hours or until the case reaches temperature or goes into defrost.

Carel Controller Standard Features

- Located at Top Right of Each Case
- 24-Hour Time Clock
- Battery Backup

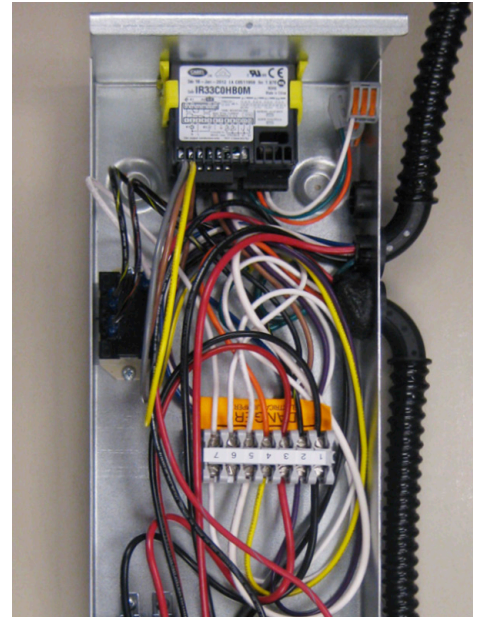

Instructions for Setting the Time

CONTROLLER TIME OF DAY MUST BE SET AT INSTALL.

1. Press and hold the Program **[Prg]** button down for 5 seconds. Set Point “**St**” will be shown on the display.
2. Press the **[Down]** arrow once. Time Clock “**tc**” will be shown on the display.
3. Press the **[Set]** button once. The year “**yxx**” will be shown on the display where “xx” is the last 2 digits of the year.
4. Press the **[Down]** arrow once. This will cycle the control to the minutes setting. “**nxx**” will be shown on the display where “xx” is a number between 00 and 59.
5. Press the **[Set]** button. The display will show a number between 00 and 59. Use the **[Up]** and **[Down]** arrows to change the number to the correct minutes setting. (Example: If it is 7:42 AM, change the number to 42.)
6. Press the **[Set]** button again to back out of the menu.
7. Press the **[Down]** arrow once. This will cycle the control to the hours setting. “**hxx**” will be shown on the display where “xx” is a number between 00 and 23.
8. Press the **[Set]** button. The display will show a number between 00 and 23. Use the **[Up]** and **[Down]** arrows to change the number to the correct hour setting. The clock reads in military time. (Example: If it is 7:42 AM, change the number to 7 and if it is 3:42 PM, change the number to 15.)
9. Press the **[Set]** button again to back out of the menu.
10. When finished, you **MUST** press and hold the **[Prg]** button for 10 seconds for the changes to take effect.

OPERATION

Turning the Lights On & Off

The on/off switch for the LED lights are located at the top of the inside door frame in the right-hand door of each case.

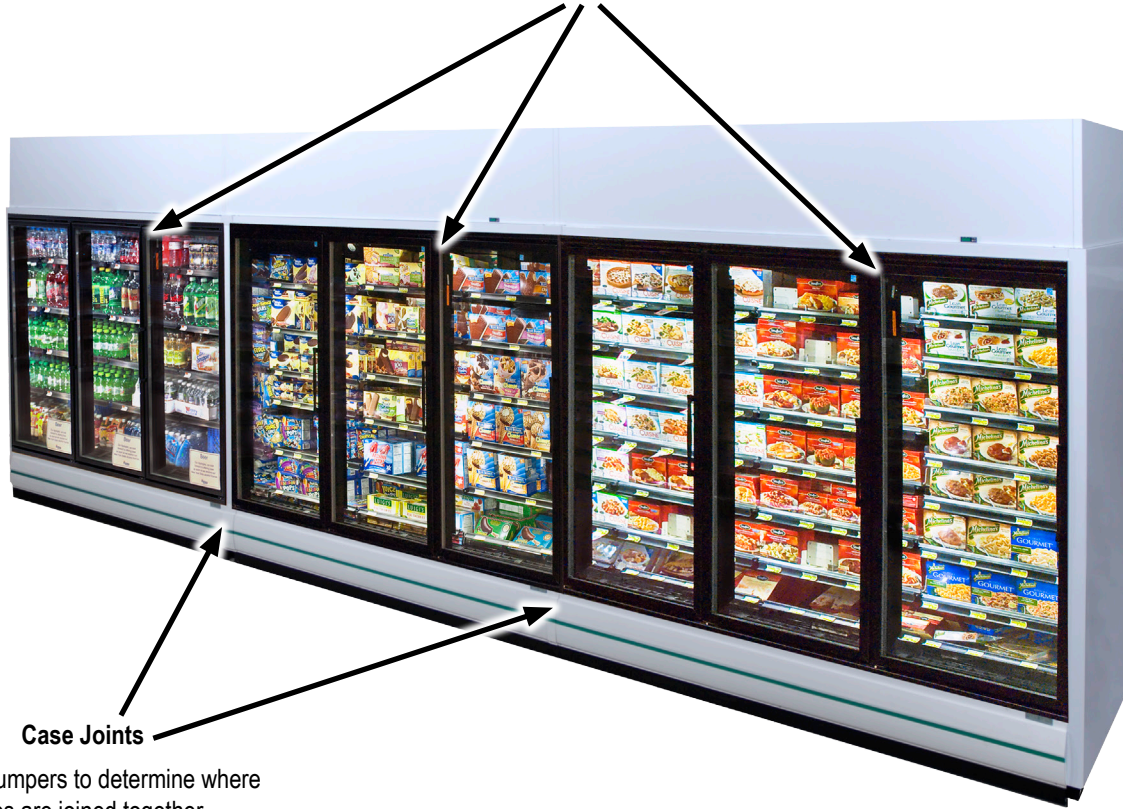

Case Joints

Look at bumpers to determine where cases are joined together.



The on/off light switch is located on the left mullion in the right-hand door of each case.

Note: To control lighting in a solid door case, use the toggle switch located in the right-hand door under the light bulb.

OPERATION

Automatic Hold-Open Doors



Hold-opens for doors are found at the top of the door. To lock a door in the open position for stocking, continue to open the door until you feel the top “hold open” device fully engage. When you let go of the door, it will remain open. To disengage the hold open feature, simply close the door.

MAINTENANCE

Solid Shelf Installation & Removal



INSTALLATION: Determine the correct shelving location. While lifting the front of the shelf up at a slight angle, insert the shelf tangs into the slots in the shelf standards at the back of the case, making sure the shelf is level left to right. Lower the front of the shelf while continuing to move the shelf tabs into the standards and until the shelf is held securely by the standards.



REMOVAL: Tilt the front of the shelf up while lifting the entire shelf up and pulling out until the shelf tangs clear the shelf standards.

MAINTENANCE

Wire Shelf Installation & Removal



INSTALLATION: Determine the correct bracket and shelving location. While lifting the front of one bracket up at a slight angle, insert the shelf bracket tangs into the slots in the shelf standard at the back of the case. Continue lowering the shelf bracket until the shelf bracket is held securely by the standard. Repeat the process for the opposite shelf bracket. Make sure the shelf brackets are level left to right. Place rear of shelf down and onto the rear of the shelf brackets. Swing the front of the shelf down until securely held by both shelf brackets.



REMOVAL: Lift the front of the shelf and then the rear of the shelf. Tilt the front of the shelf bracket up and pull out until the shelf bracket tangs clear the shelf standard. Repeat the process for the opposite shelf bracket.

MAINTENANCE

Bottom Electrical Box Wire Colors (VZCH/VCCH Only)

****VLCH/VMCH do not use a bottom electrical box**

- Anti-Sweat Heat:
 - Purple Wires: Perimeter
 - Red Wires: Mullion
 - Orange Wires: Doors
- Lighting:
 - Brown & Black Wires
- Defrost Heaters - Low Temp Only (2):
 - Brown Wire: In Series with 80°F High Limit
 - Black Wire: Defrost Heater
- Fans:
 - Blue Wire



Medium temp case shown. No connections required.

MAINTENANCE

Instructions for Condensate Removal Systems with Condensate Evaporation Pan

Stores without floor drains are using the Condensate Removal System with a Condensate Evaporation Pan. This is a tray located under the kickplate with a submersible pump that will pump the water to the top of the case and into a Condensate Evaporation Pan. The Condensate Evaporation Pan has a float switch that will power its heater when the water rises.

NOTE: Anything spilled inside the case will end up in the pump pan and then into the Condensate Evaporation Pan where it will be heated and cause an odor.

When you have water on the floor, you will need to check the condensate system.

CLEANING INSTRUCTIONS

- Pump pan (behind kickplate) requires regular cleaning.
- Avoid washing (flooding) inside of case with large amounts of water at one time.
- The water removal system for 2 to 5-door cases holds two gallons of liquid. 1-door water removal system holds one gallon of liquid. When cleaning the case, do not use more than this amount of liquid.
- The pump sits in the pan and removes water slowly.
- Large amounts of water dumped down the drain will overflow the pan.
- **When you know milk or other liquids are spilled down into the pump pan you should clean the pump pan.**
- Sediment, paper tags, and other debris will clog either the pump or the plastic tubing leading to the Condensate Evaporation Pan.
- Spoiled milk will smell bad if it sits in the pump pan.
- Heated spoiled milk will smell – avoid letting this be pumped up to the Condensate Evaporation Pan.
- **Cleaning:** Both the pump pan and the Condensate Evaporation Pan can be cleaned with soap and water.
- **Block the case drain when you wash out the case** – unless you plan to clean the pump pan at the same time.

The Condensate Removal System requires regular maintenance. A dirty pump pan and a dirty Condensate Evaporation Pan are not covered by warranty service.

WATER ON THE FLOOR

Is there water on the floor at the front of the case? Does it smell? Stores without floor drains use condensate evaporate pans and pumps. These need regular MONTHLY cleaning.

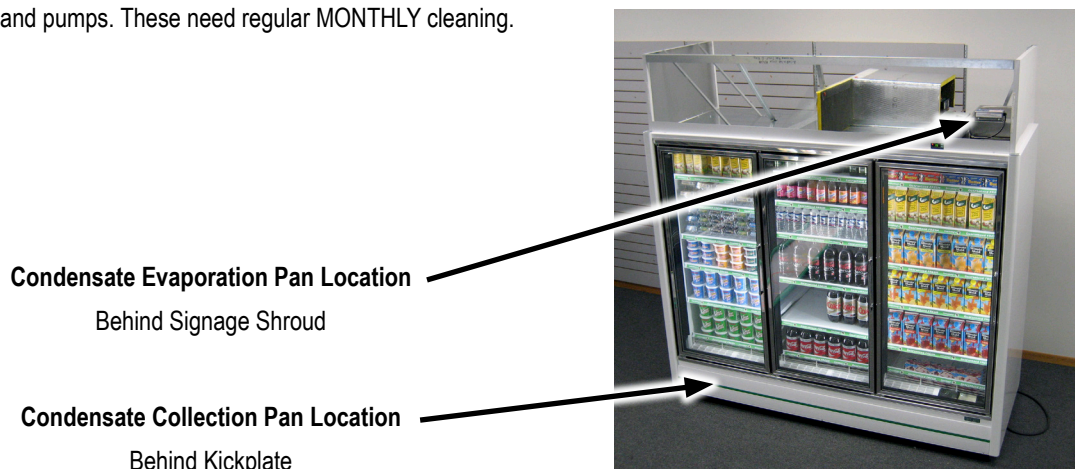

MAINTENANCE

Refrigeration Cleaning & Maintenance

The medium and low temp cases should be thoroughly cleaned routinely to maintain a clean appearance. Use bleach solution to wipe out the inside of the case. Wash down all glass doors with glass cleaner. The case drain should be regularly cleared of debris and price tags to prevent clogging.

Preventative Maintenance - Condensing Units & Evaporator Coils

(To be completed by licensed, trained, and authorized persons only.)

VACUUM THE CONDENSER COIL SURFACE EVERY 3 MONTHS.

Annual checkup:

1. Check and tighten ALL electrical connections.
2. Check all wiring and insulators.
3. Check contactors for proper operation and for worn contact points.
4. Check all fan motors. Tighten motor mount bolts/nuts and tighten fan set screws.
5. Check the refrigerant and oil level in the system.
6. Check the operation of the control system. Make certain all safety controls are operating properly.
7. Check that all defrost controls are functioning properly.
8. Clean the evaporator coil surface.
9. Clean the evaporator drain pan and check the drain pan and the drain line for proper drainage.
10. Check and tighten all flare connections.

MAINTENANCE

Carel Controller Programming Instructions

The Carel controller has a two-level menu system for programming the operation of the case. Level 1 program settings are the most frequently accessed parameters. These items are used to make simple changes to the operation of the case. Level 2 program settings control more complicated aspects of the case operation and, therefore, require the use of a password to gain access.

HOW TO CHANGE LEVEL 1 CONTROL SETTINGS

1. Press and hold the Program **[Prg]** button down for 5 seconds. “**St**” will be shown on the display.
2. Use the **[Up]** and **[Down]** arrows to move up or down the menu until you reach the parameter you intend to view or change. When the proper code is displayed, press the **[Set]** button to view the current setting for that parameter.
3. Use the **[Up]** and **[Down]** arrows to change the value. Then press the **[Set]** button again to return to the menu.
4. The only exception to Step #3 is the real time clock, program code “**tc**”. In this case, you must press the **[Set]** button in order to access the submenu of available settings for the “**tc**” parameter. Then press the **[Up]** and **[Down]** arrows to move up and down the submenu. Once changes are made in this submenu, press the **[Prg]** button to get back to the main menu.
5. When finished making all necessary changes, you **MUST** press and hold the **[Prg]** button for 10 seconds to save them. Alternatively, if you decide you do **NOT** want to save changes you’ve just made, simply stop pressing buttons for 30 seconds and the control will return to normal operation, discarding any changes made.

HOW TO CHANGE LEVEL 2 CONTROL SETTINGS

6. Press and hold the **[Prg]** and **[Set]** buttons down for 5 seconds. The display will show a flashing “**0**”.
7. Use the **[Up]** arrow until the display reads “**22**” (this is the password), then press the **[Set]** button. The display will read “**/P**”.
8. Use the **[Up]** and **[Down]** arrows to move up or down the menu until you reach the parameter you intend to view or change. When the proper code is displayed, press the **[Set]** button to view the current setting for that parameter. (You will notice the Level 1 program codes are also found in this menu.)
9. Use the **[Up]** and **[Down]** arrows to change the value. Then press the **[Set]** button again to return to the menu.
10. The exceptions to Step #4 are the program codes “**tc**”, “**td1**”, and “**td2**”. In these cases, you must press the **[Set]** button in order to access the submenu of available settings for these parameters. Once changes are made in this submenu, press the **[Prg]** button to get back to the main menu.
11. When finished making all necessary changes, you **MUST** press and hold the **[Prg]** button for 10 seconds to save them. Alternatively, if you decide you do **NOT** want to save changes you’ve just made, simply stop pressing buttons for 30 seconds and the control will return to normal operation, discarding any changes made.

Note: Zero Zone should be contacted before working on changing settings. To be completed by a trained person only.

MAINTENANCE

Carel Controller Low Temp Codes

3-5 DOOR LOW TEMP LEVEL 1			1 & 2 DOOR LOW TEMP LEVEL 1			IM BOTTOM-MOUNTED COIL LEVEL 1		
Code	Name	Factory Set	Code	Name	Factory Set	Code	Name	Factory Set
St	Set point	-10	St	Set point	-10	St	Set point	7
rd	Differential	6	rd	Differential	6	rd	Differential	4
dl	Defrost interval	12	dl	Defrost interval	12	dl	Defrost interval	12
dt1	Defrost end temp	70	dt1	Defrost end temp	45	dt1	Defrost end temp	70
dP1	Defrost duration	40	dP1	Defrost duration	30	dP1	Defrost duration	40
d/1	Defrost probe temp	(actual)	d/1	Defrost probe temp	(actual)	d/1	Defrost probe temp	(actual)
tc.y	RTC year	-	tc.y	RTC year	-	tc.y	RTC year	-
tc.m	RTC month	-	tc.m	RTC month	-	tc.m	RTC month	-
tc.d	RTC day of month	-	tc.d	RTC day of month	-	tc.d	RTC day of month	-
tc.u	RTC day of week	-	tc.u	RTC day of week	-	tc.u	RTC day of week	-
tc.h	RTC hour	-	tc.h	RTC hour	-	tc.h	RTC hour	-
tc.m	RTC minute	-	tc.m	RTC minute	-	tc.m	RTC minute	-

LOW TEMP LEVEL 2			1 & 2 DOOR LOW TEMP LEVEL 2			IM BOTTOM-MOUNTED COIL LEVEL 2		
Code	Name	Factory Set	Code	Name	Factory Set	Code	Name	Factory Set
/A2	Probe 2 configuration	2	/A2	Probe 2 configuration	2	/A2	Probe 2 configuration	2
c1	Min time between starts	5	c1	Min time between starts	5	c1	Min time between starts	5
c2	Min comp OFF	1	c2	Min comp OFF	1	c2	Min comp OFF	1
c3	Min comp ON	1	c3	Min comp ON	1	c3	Min comp ON	1
d0	Defrost type	4	d0	Defrost type	0	d0	Defrost type	4
dd	Drip time	1	dd	Drip time	1	dd	Drip time	1
dn	Defrost duration %	100	dn	Defrost duration %	100	dn	Defrost duration %	100
AL	Low temp alarm	-20	AL	Low temp alarm	-20	AL	Low temp alarm	-20
AH	High temp alarm	10	AH	High temp alarm	10	AH	High temp alarm	25
F0	Fan management	2	F1	Fan start temp	30	F0	Fan management	2
F1	Fan start temp	30	H0	Serial address	1	F1	Fan start temp	30
H0	Serial address	1	H1	Function of relay 4	10	H0	Serial address	1
H1	Function of relay 4	10	td1.d	Defrost time day 1	11	H1	Function of relay 4	10
td1.d	Defrost time day 1	11	td1.h	Defrost time hour 1	8	td1.d	Defrost time day 1	11
td1.h	Defrost time hour 1	8	td1.m	Defrost time minute 1	0	td1.h	Defrost time hour 1	8
td1.m	Defrost time minute 1	0	td2.d	Defrost time day 2	11	td1.m	Defrost time minute 1	0
td2.d	Defrost time day 2	11	td2.h	Defrost time hour 2	20	td2.d	Defrost time day 2	11
td2.h	Defrost time hour 2	20	td2.m	Defrost time minute 2	0	td2.h	Defrost time hour 2	20
td2.m	Defrost time minute 2	0				td2.m	Defrost time minute 2	0

65-0703 Rev G

65-1372 Rev A

65-1093 Rev B

Note: Carel Controller Codes/factory set points listed on this page are standard codes. For customer specific information, please see the Carel label on top of the electrical box cover on top of the case.

MAINTENANCE

Carel Controller Medium Temp Codes

MEDIUM TEMP LEVEL 1		
Code	Name	Factory Set
St	Set point	34
rd	Differential	4
dt1	Defrost end temp	50
dP1	Defrost duration	30
d/1	Defrost probe temp	n/a
tc.y	RTC year	-
tc.m	RTC month	-
tc.d	RTC day of month	-
tc.u	RTC day of week	-
tc.h	RTC hour	-
tc.m	RTC minute	-

MEDIUM TEMP LEVEL 2		
Code	Name	Factory Set
/A2	Probe 2 configuration	0
c1	Min time between starts	5
c2	Min comp OFF	1
c3	Min comp ON	1
d0	Defrost type	2
dl	Defrost interval	12
dd	Drip time	1
dn	Defrost duration %	100
AL	Low temp alarm	30
AH	High temp alarm	50
F0	Fan management	0
F1	Fan start temp	5
H0	Serial address	1
H1	Function of relay 4	10
td1.d	Defrost time day 1	11
td1.h	Defrost time hour 1	8
td1.m	Defrost time minute 1	0
td2.d	Defrost time day 2	11
td2.h	Defrost time hour 2	20
td2.m	Defrost time minute 2	0

65-0704 Rev F

MAINTENANCE

Carel Controller Basic Operations

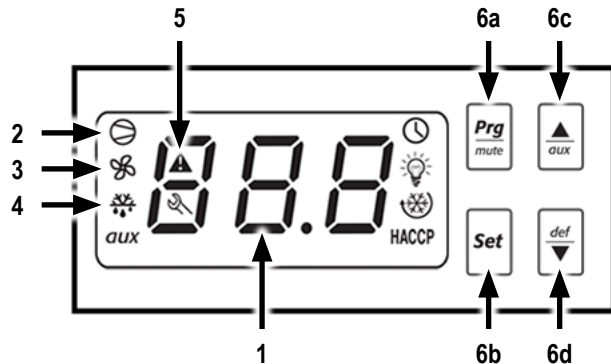

1. **Temperature Display:** The temperature of the case is displayed here. When the case is in defrost mode, this display will read DEF.
2. When lit, this icon indicates the compressor is running.
3. When lit, this icon indicates the fans are running.
4. When lit, this icon indicates the defrost heater is activated.
5. This icon flashes in an alarm situation.
6. **Buttons:**
 - a. **Prg/mute:** This button is used to silence the audible alarm. The alarm will re-energize after 60 minutes if the condition that caused it has not been corrected. This button is also used to make basic changes to the program and should be used only by a qualified service technician.
 - b. **Set:** This button is used to program the control and should be used only by a qualified service technician.
 - c. **Up Arrow/aux:** This button is used to program the control and should be used only by a qualified service technician.
 - d. **Down Arrow/def:** This button is used to program the control and should be used only by a qualified service technician.

Basic Case Operations

1. The case's condensing unit (mounted on top of the case) cycles off and on during normal operation. When the inside of the case is warm, the compressor turns on. When the inside of the case is cold, the compressor turns off.
2. On medium temp cases, the fans run all of the time. On low temp cases, the fans run when the evaporator temperature is below 30°F, except when in defrost.
3. The case goes into defrost two times per day. The defrost lasts between 30 and 50 minutes. At the end of the defrost, the low temp doors may fog on the inside. This is normal. During the defrost, the air in the ducts can warm up to 40°F for a medium temp case and 60°F for a low temp case. Product temperatures within the case will not rise above acceptable levels, however. Product in medium temp cases will remain at or below 41°F and product inside low temp cases will remain frozen.*
4. The lights remain on at all times unless the light switch located in the right-hand door frame is switched off.
5. The water removal system has a maximum capacity of two gallons. When cleaning the interior of the case, do not use more than this amount of liquid.

**Please consult the Zero Zone Service Department on case defrost characteristics for non-standard defrost settings.*

MAINTENANCE

Silencing the Carel Temperature Alarm



The button used to silence the alarm ([Prg] button) is located on the controller on the front of the case above the right-hand door. If the alarm sounds, push the [Prg] button which will reset the alarm and silence it for one hour.

Alarm Instruction Label
An instruction label for the electronic control can be found affixed to the ceiling of each case inside the right-hand door.

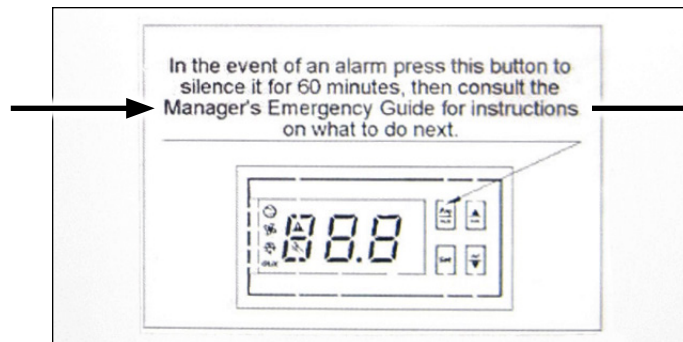

See "**Manager's Emergency Guide**" at the end of this manual.

MAINTENANCE

Conditions that Trigger the Carel Alarm

Your LOW TEMP case has two defrosts programmed per day, one at 8:00 AM and one at 8:00 PM. A typical defrost lasts one hour. Your MEDIUM TEMP case has two defrosts programmed per day, one at 8:00 AM and one at 8:00 PM. If the alarm sounds during this time, please allow an additional one-hour recovery time before calling for service.

If the alarm sounds outside of the above times, please review the following checklist. If you've checked all of these items and the case still does not work properly, submit a service request.

Cases with electronic controls (a digital display cut into the shroud above the doors) have a one-hour delay after defrost. The controller has a 10°F high alarm set point. The alarm will sound when the sensed temperature is at or above 10°F for a period of 60 minutes. If the temperature drops below 10°F during this 60 minutes, the alarm timer will reset. If the case is in defrost, the electronic display will read "DEF".

Common Things to Check

DEFROST AND ALARMS

1. Check the circuit breakers for the cases. Tripped circuit breakers will cut off the power to the cases and to the alarms.
2. Reach-in door LOW TEMP cases have a one-hour defrost. Check the following before you enter a service request.
 - Determine when the defrost cycle started (typically at 8:00 AM or 8:00 PM). Please wait one hour and double check case status before calling for service.
 - The fans turn off during defrost and for a few minutes after defrost.
 - Has the case just been stocked? (Warm product will take 24 hours to cool down.)
 - Is the case heavily shopped? (Frequent door opening will warm the case.)
 - Do not block return air grills at the bottom of the low temp case.
3. Reach-in door MEDIUM TEMP cases also have a defrost time. Check the following before you enter a service request.
 - Medium temp fans run while in defrost and lights remain on.
 - Typically medium temp cases defrost at 8:00 AM and 8:00 PM.
 - Has the case just been stocked? (Warm product will take 24 hours to cool down.)
 - Is the case heavily shopped? (Frequent door opening will warm the case.)

MAINTENANCE

Condensing Unit Pressure Switch Settings

ADJUSTABLE DUAL PRESSURE CONTROL (USED FOR COOLERS AND FREEZERS)

- Low pressure cut in/differential (PSI): 30/20
- High pressure cut out/differential (PSI): 350/60









FIXED PRESSURE CONTROLS (USED FOR COOLERS)

- Low pressure cut in/out (PSI): 35/15
- High pressure cut/out (PSI): 440

ELECTRONIC UNIT CONTROL (USED FOR FREEZERS)

- Low pressure control: Suction pressure transducer (on process port of compressor; has a Schrader valve)
- Low pressure cut-in: 30 psig
- Low pressure cut-out: 10 psig
- High pressure UL safety control: Encapsulated (fixed mechanical switch; no manual reset)
- High pressure cut-out: 440 psig
- Time delay: Built-in (2 sec delay on startup; 6 sec anti-short cycling delay)
- Manual restart or dead band reset: Built-in (hold “restart” button for 3 seconds when suction pressure is between cut-in and cut-out valves)
- Electronic service menu: Compressor starts and runtime for compressor
- Alarms
 - HP - High pressure trip alarm (automatic reset)
 - HPL - High pressure trip lock-out trip alarm (locks after “HP” alarm happens 4 times in 1 hour; manual reset)
 - P1 - Suction probe failure (goes into “failsafe mode” - 5 minutes on, then 5 minutes off)
 - Pon - Keypad unlocked
 - PoF - Keypad locked
 - EE - Module failure
- Additional information about EUC
 - When the EUC is powered, the compressor light will be on (pressure above 10 psi), unless you are in a dead band. Look at the Carel case controller to identify if the case is calling to have the compressor running.
 - The EUC is a compressor low pressure safety. The compressor will stop when the pressure is below 10 psi, regardless of what the case control signal is. After a safety trip, the compressor will restart when the pressure rises above 30 psi and the case control is calling for cooling.

Accessing Alarm Code Information

Press and release ALARM	
Cycle through menu options – UP/DOWN	 
Press SET to see number of alarms	
Press SET again to return to menu options	
Exit menu - UP and SET	  

OPTIONS

Sound Attenuation Kit & Balloon Guard

Prior to assembling and attaching the sound attenuation kit, all of the condensing unit electrical and refrigeration connections should be completed. The condensing unit must then be squared up in relationship to the case.

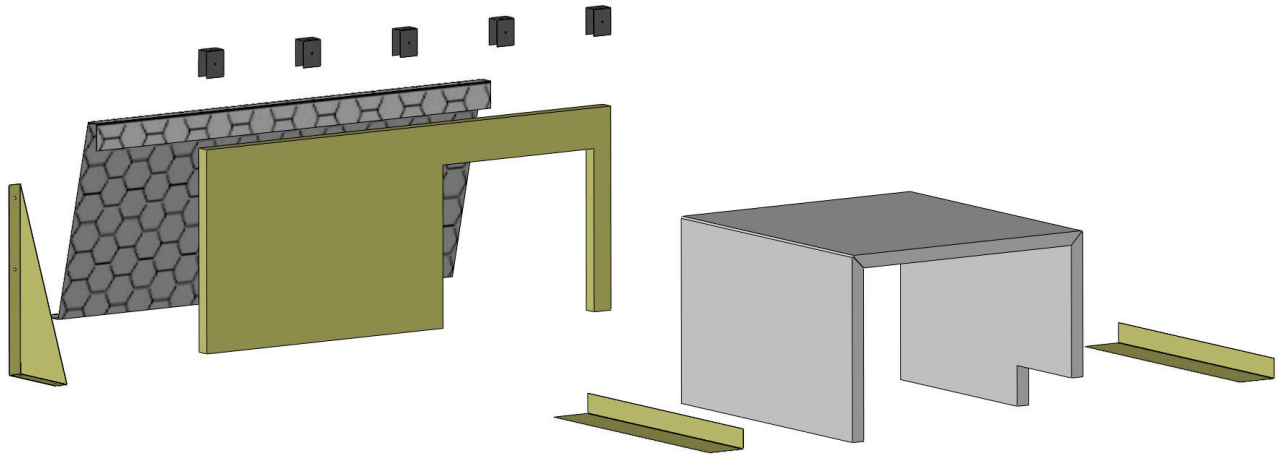

Sound Attenuation Kit Exploded View

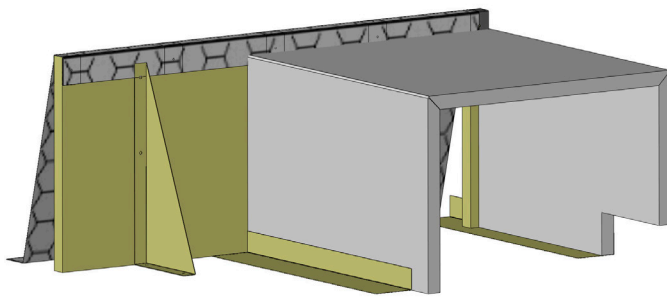

Sound Attenuation Kit Assembled

SOUND ATTENUATION KIT INSTALLATION SEQUENCE

1. Install angle brace with 2-3 #8-18 x 1/2 hex tek screws (provided).
2. Install large pre-cut insulation U-box and form to shape. Orientate with corner cutout notch for refrigeration piping quick connections to rear of case.
3. Position large 1-piece baffle with coil opening cut out in front of U-shaped box. Secure in place with brace.

BALLOON GUARD INSTALLATION SEQUENCE

1. Install balloon guard metal screen at an angle using (5) Bracket U-clips and screw #10 x 3/4" tek. Guard angle might vary depending on height of insulation components.
2. Secure the metal screen to the case ceiling with (3) #8-18 x 1/2" hex, tek screws.
3. Make necessary adjustment to metal screen to fit properly.

For more detailed instructions, please contact Zero Zone.

OPTIONS

End Close-Off

Cases ordered with end close-off panels will receive either 12" or 16" panels and are to be installed from the case end panel to the wall.

Fan Kit

The fan kits are optional and are designed to prevent condensation on the wall and under the case in store conditions over 75°F and 55 relative humidity.

Complete instructions are included with the fan kit.

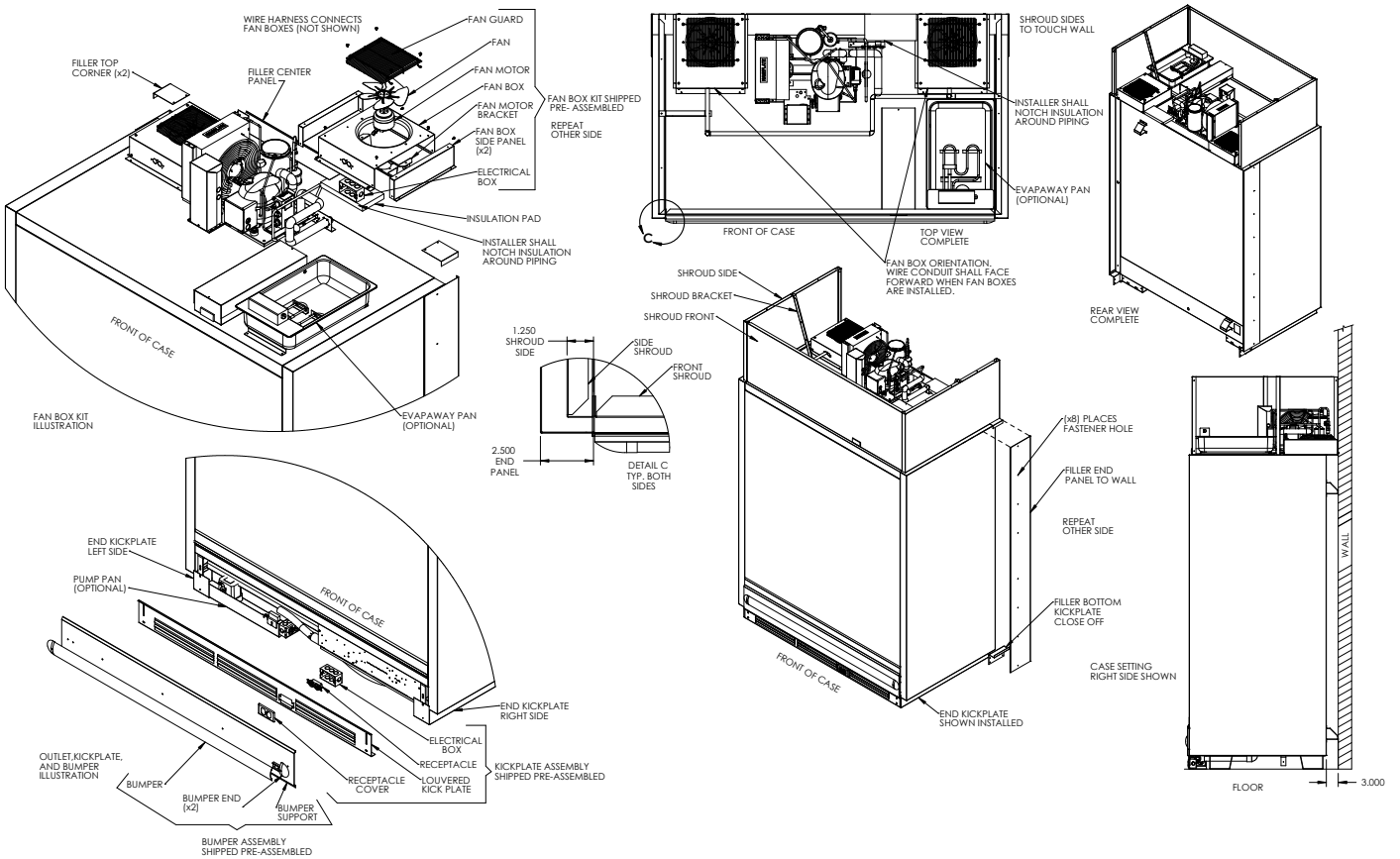

OPTIONS

Shroud Frame Assembly



1. Locate the painted lower shroud of the appropriate length. (**Note:** Shroud sides are shipped inside the case.)

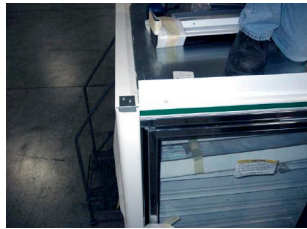

2. Working from left to right (facing the case), position the lower shroud by placing it against top Euro trim to the front and to the edge of the end panel to the left.



3. Secure with self-tapping sheet metal screws (three per piece).

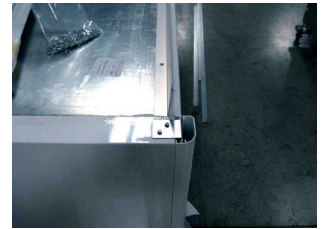

4. Complete.



5. Locate the 2nd painted lower shroud of the appropriate length and secure in the same fashion. In this example, butting up to the edge of the insulated divider. (There will be a vertical joint for the insulated divider.)



6. Remove the cover from the electrical box and remove the two screws that secure the electrical box to the top of the case.



7. Slide the electrical box into position making sure that the Carel Controller display is clearly visible through the cutout in the lower shroud.



8. Re-fasten the electrical box with the same screws you removed. This procedure will be duplicated at each case.



9. Remove one of the two screws from the Euro trim retainer clip (the screw closest to the case).



10. Locate a shroud side for the left of the line-up. With the finished side facing out, line up the front of the shroud tight to and even with the painted lower shroud.

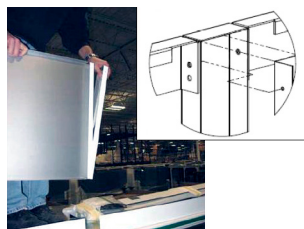

11. At the insulated divider, locate the insulated divider shroud piece. Place the shroud side into the shroud piece. The shroud piece will act as a cap to the shroud side.



12. Place the entire assembly into the gap over the insulated divider.



13. Using a self-tapping sheet metal screw, secure the shroud side to the bottom of the insulated divider shroud piece. Secure shroud side to top of case.

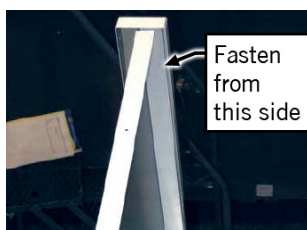

14. Note: Edge of shroud side flange is aligned with edge of case one.

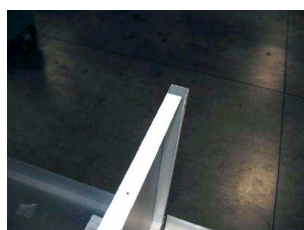

15. Note: Shroud side over plexi divider should be installed as shown.



16. Secure the shroud side with self-tapping screws making sure it is square to the front of the case.

OPTIONS

Shroud Frame Assembly (Cont.)



17. Locate the last shroud side, position as shown, and secure with sheet metal screws as before.



18. Locate two shroud support brackets and secure at the top.



19. While positioning the shroud sides plumb, secure the support brackets to the case top using self-tapping sheet metal screws.



20. At the insulated divider location, install two support brackets and secure to case top as before.



21. Due to the position of the condensate evaporation pan, this shroud side only gets one support, installed behind the pan.



22. Locate the galvanized shroud top rail of the appropriate length and secure it to the shroud side with two self-tapping screws.



23. Secure the right-hand end of the shroud top rail to the insulated divider shroud piece using two sheet metal screws.



24. Locate a shroud top rail of the appropriate length and secure it to the right side of the insulated divider shroud piece.



25. Temporarily fasten the right end galvanized shroud top rail (rail two) to the shroud side with one fastener.



26. Locate and secure the last galvanized shroud top rail (rail three) and secure it to the top of the last shroud side.



27. Remove temporary fastener of rail two and bring the tops of rail two and rail three together.



28. Secure with two sheet metal screws as shown.



OPTIONS

Special Louvered Shroud Design

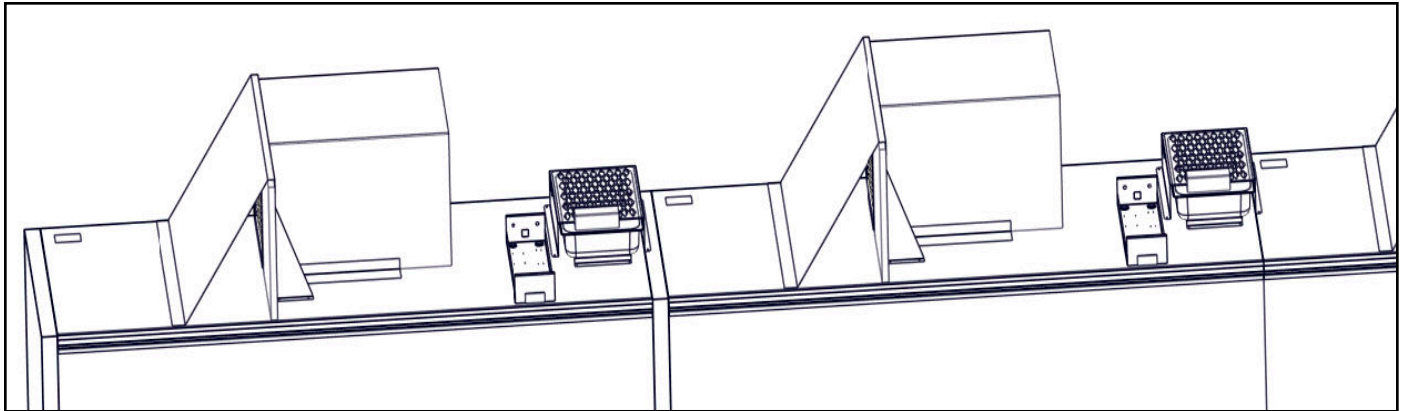

1. Lineup with no shrouds.

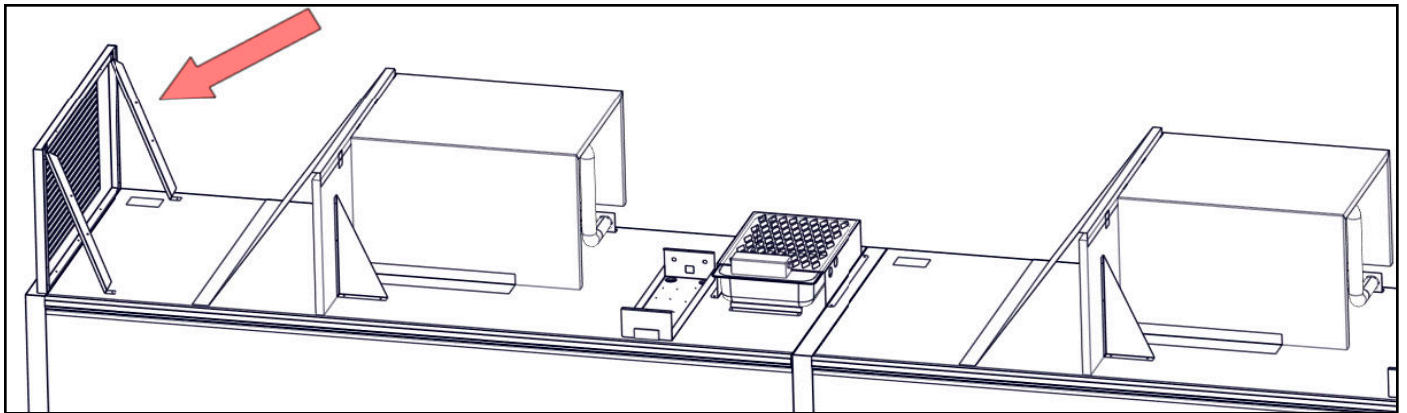

2. Install left side with louvers onto the case end panel. Align the side shroud with the back of the case. Use 3 screws and fasten to the top of the end panel. Attach 2 shroud supports to the side shroud and case.

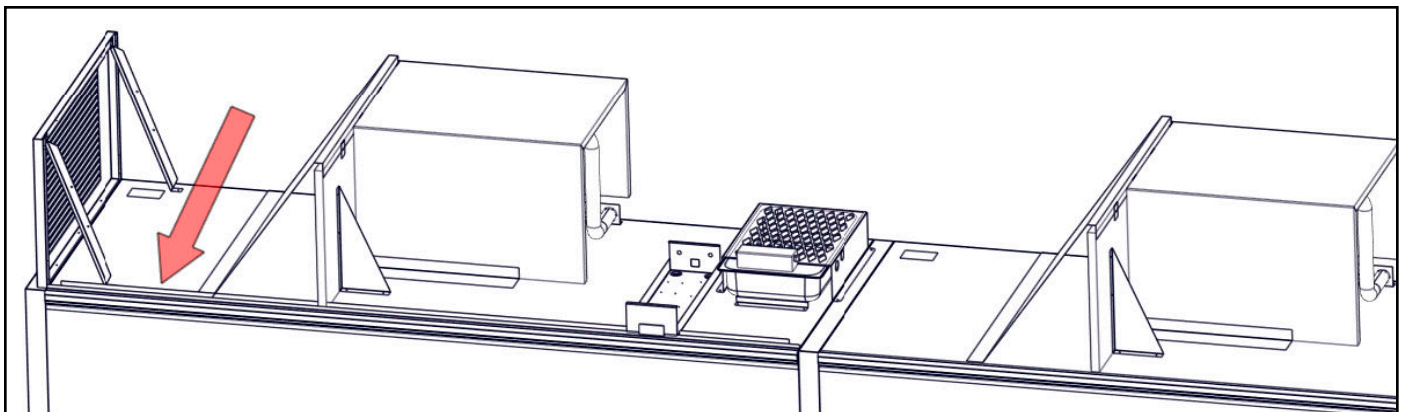

3. Aligning the shroud support channel with the side shroud. Use 5 screws and fasten to the top of the ceiling.

OPTIONS

Special Louvered Shroud Design (Cont.)

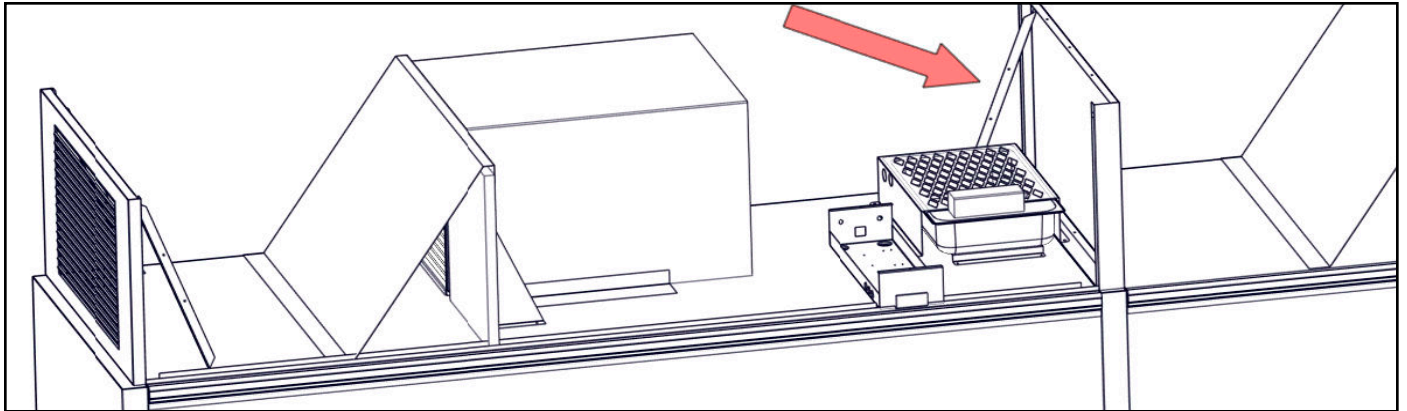

4. Align the case divider partition (2.5" side forward) with the shroud support channel. Fasten the case divider partition to the top of the insulated divider panel using 3 screws. Attach 1 shroud support to case divider partition and case, using pre-drilled hole in the case divider partition, near the rear of the case.

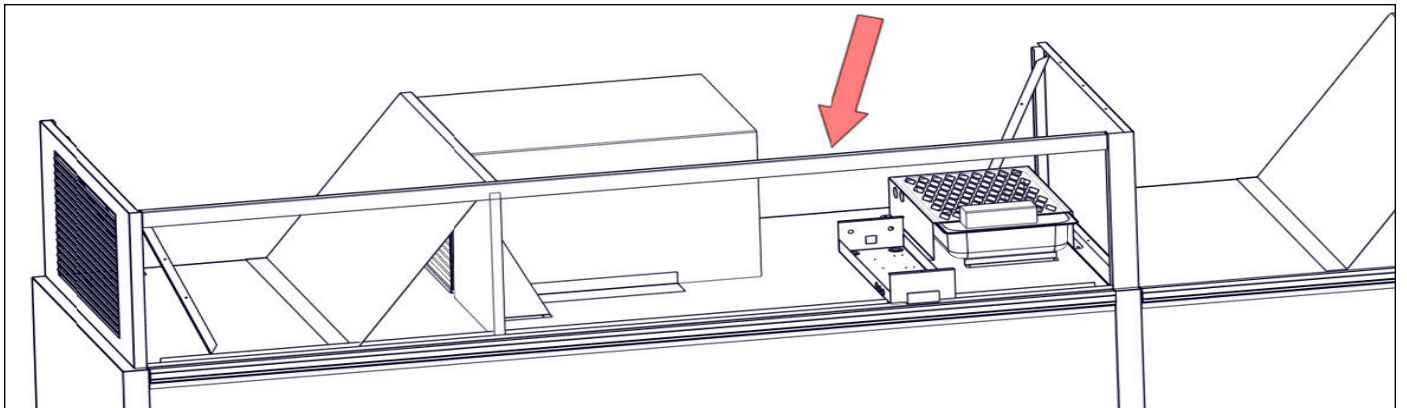

5. Using 2 screws at each end of the upper shroud support fasten it to the side shroud & case divider partition.
Note: It is recommended that there be two people (one on each end) for installing the upper shroud supports (the narrow long metal pieces that are the length of the case).

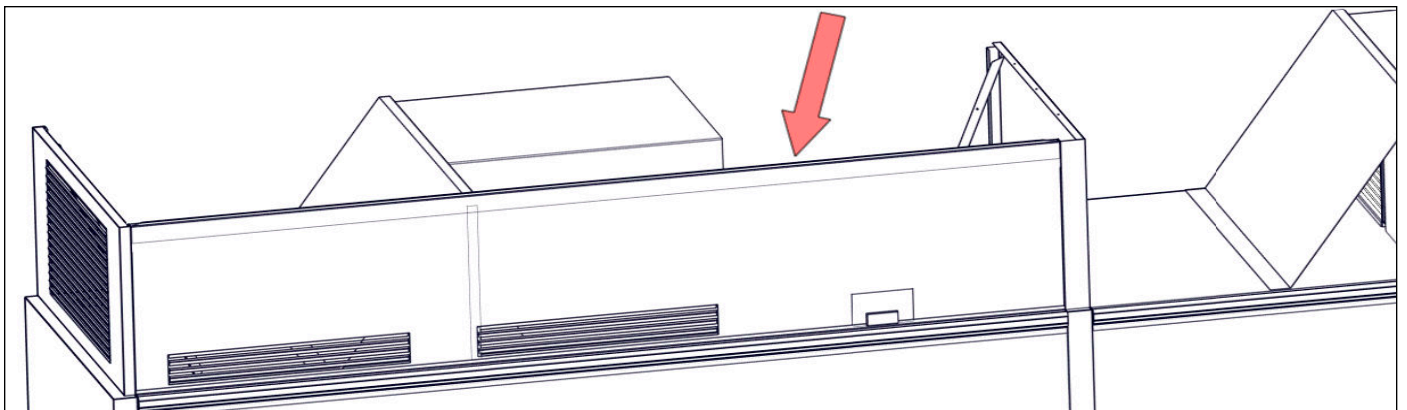

6. Hang upper shroud onto the upper shroud support & into the shroud support channel.

There will be one upper shroud per case.

OPTIONS

Special Louvered Shroud Design (Cont.)

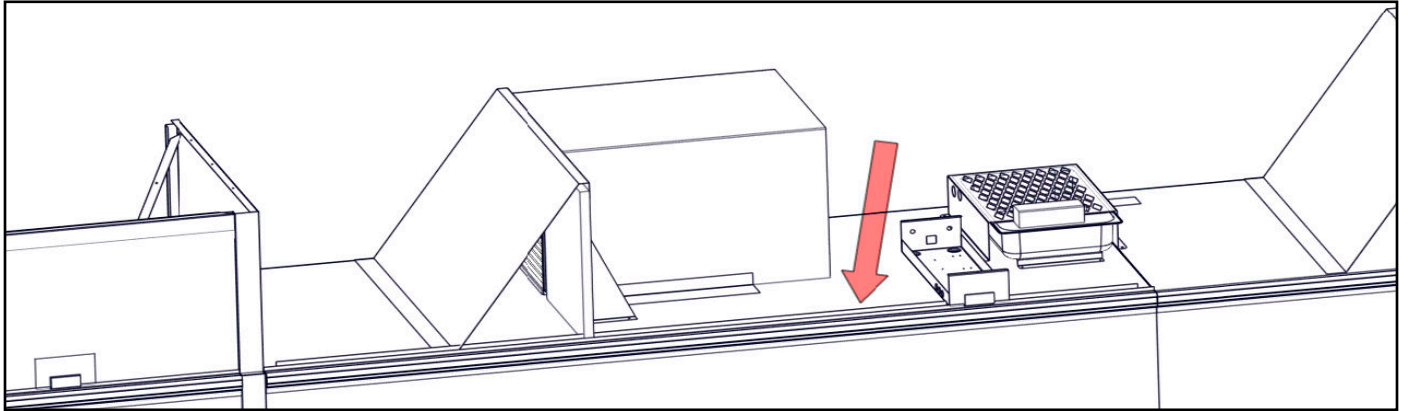

7. Align the shroud support channel with the case divider partition. Use 5 screws and fasten to the top of the ceiling.

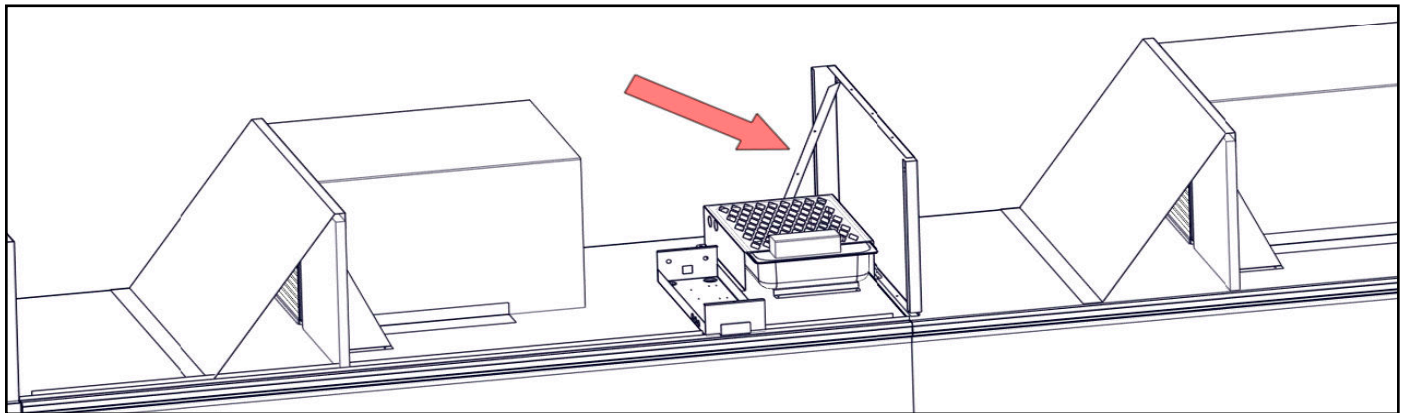

8. Align case divider partition (2.5" side towards rear of case) with the shroud support channel. Fasten case divider to ceiling using 3 screws. Attach 1 shroud support to case divider partition and case, using pre-drilled hole in the case divider partition, near the rear of the case.

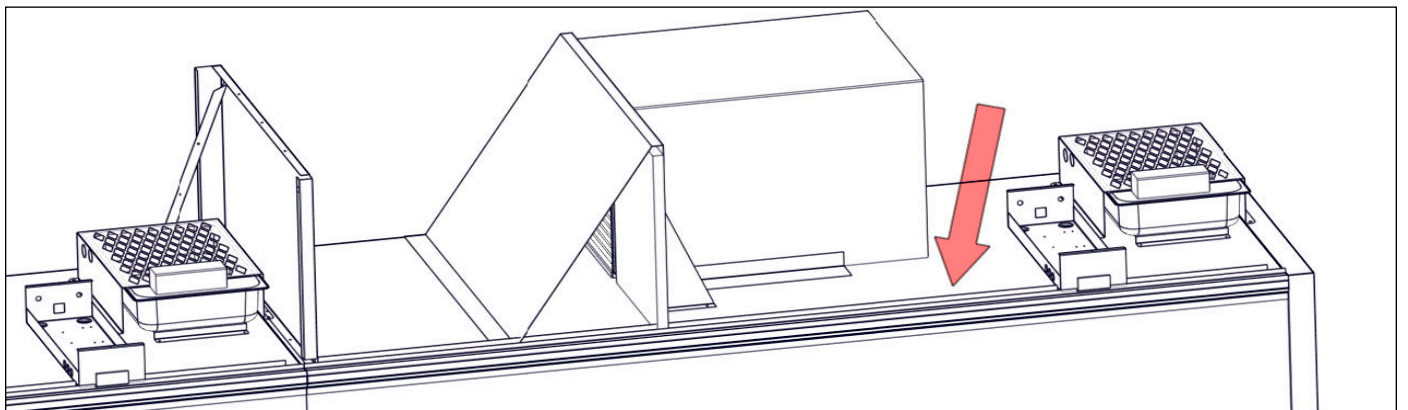

9. Align shroud support channel with the shroud support channel on the adjacent case. Use 5 screws and fasten to the top of the ceiling

OPTIONS

Special Louvered Shroud Design (Cont.)

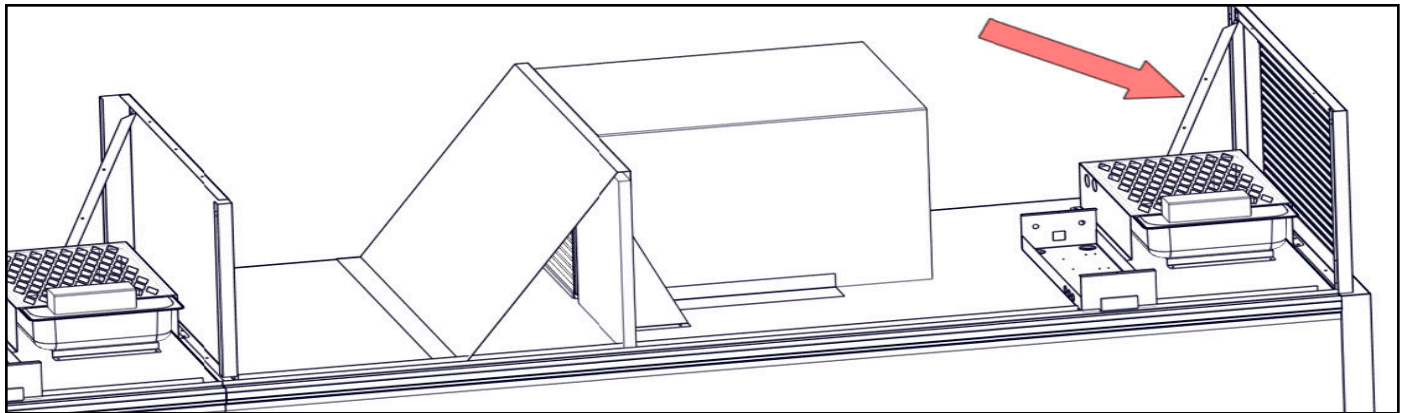

10. Install right side shroud with louvers onto the case end panel. Align the side shroud with the back of the case. Use 3 screws and fasten to the top of the end panel. Attach 1 shroud supports to the side shroud and case. **Note: It is recommended that there be two people (one on each end) for installing the upper shroud supports (the narrow long metal pieces that are the length of the case).**

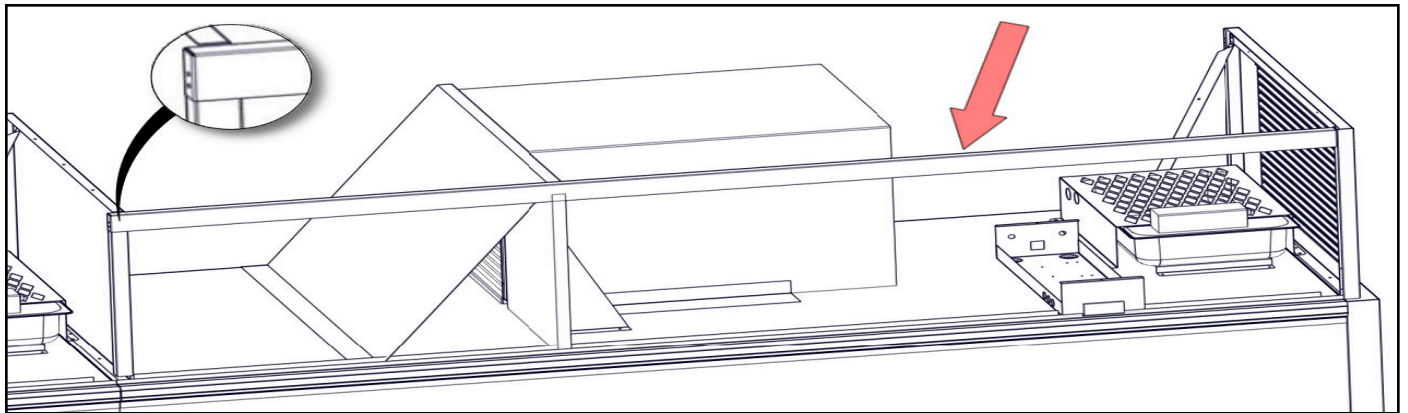

11. Place left end of upper shroud support onto the case divider partition. Using 2 screws, fasten the right end of the upper shroud support to the side shroud.

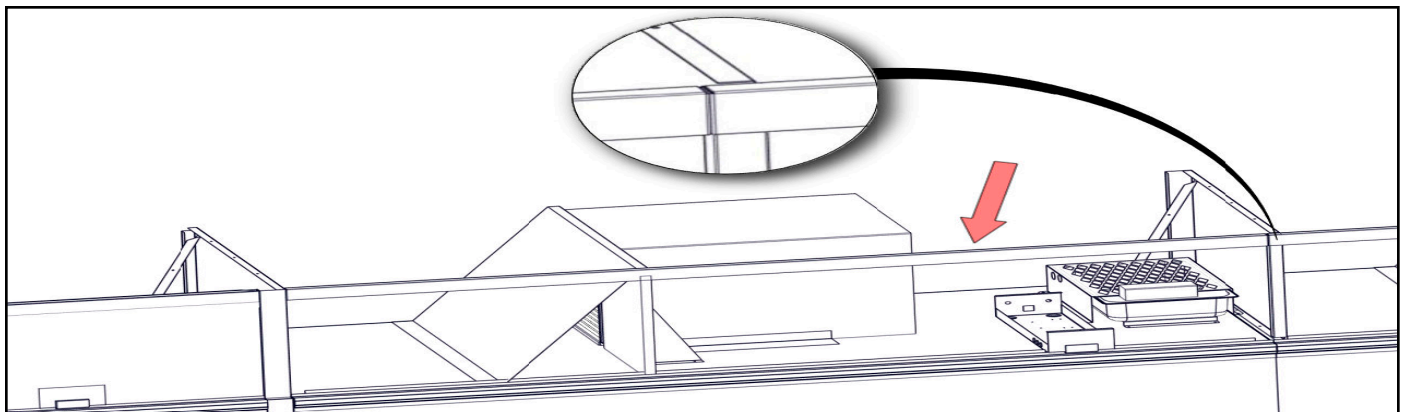

12. Using 2 screws at each end of the upper shroud support, fasten it to both case divider partitions. On the right side, you will end up fastening both upper shroud supports to that case divider partition with those 2 screws.

OPTIONS

Special Louvered Shroud Design (Cont.)

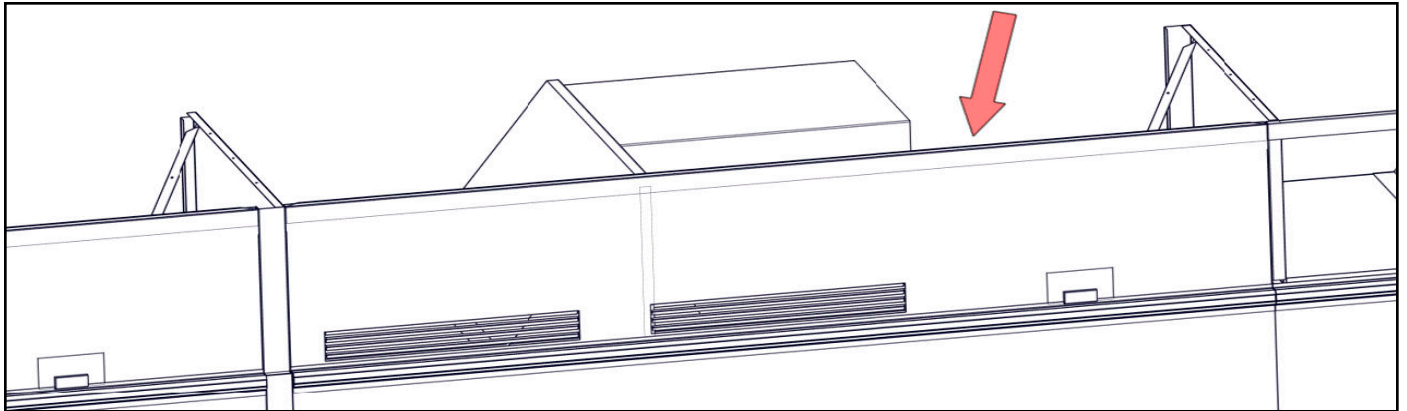

13. Hang upper shroud onto the upper shroud support & into the shroud support channel.

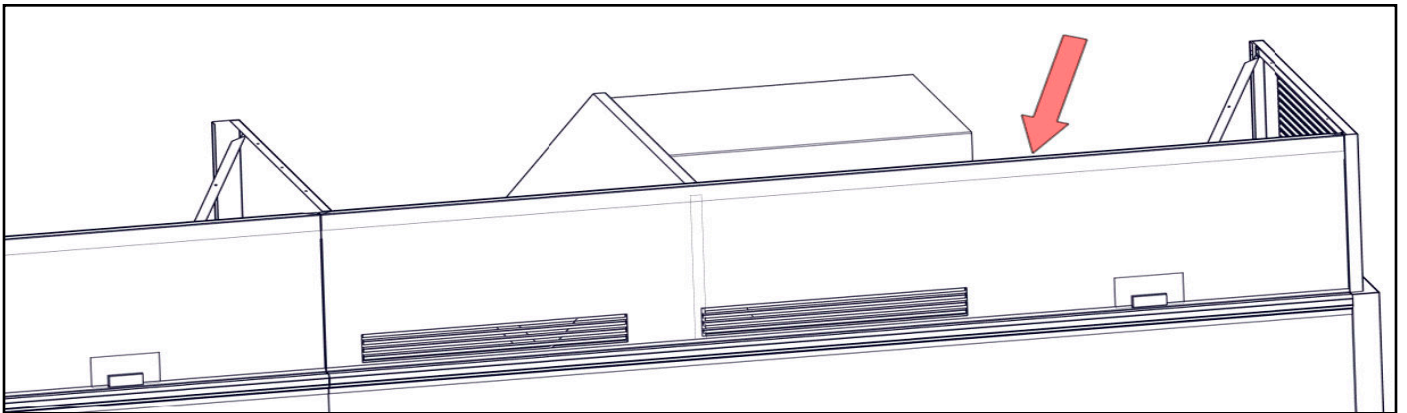

14. Hang upper shroud onto the upper shroud support & into the shroud support channel.

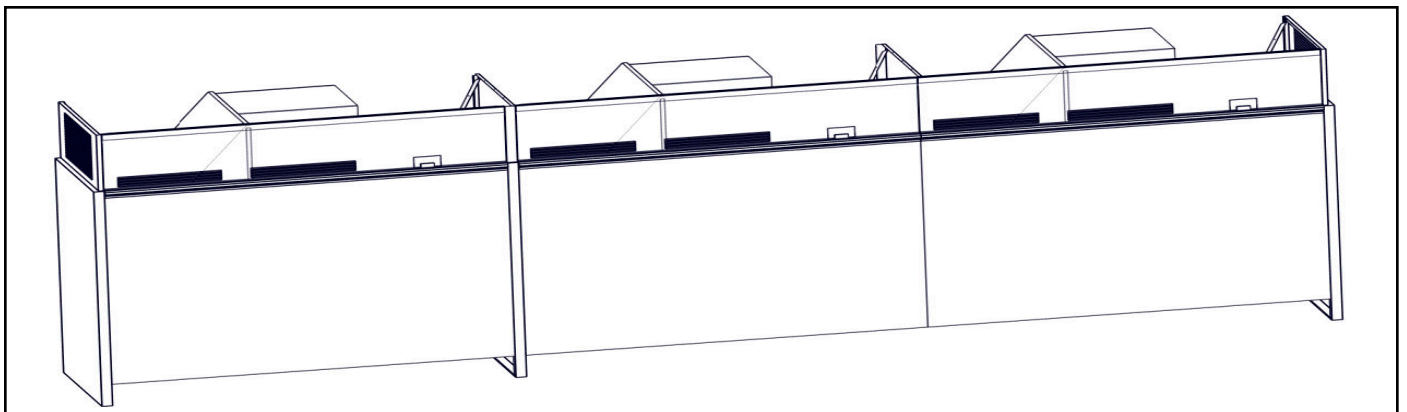

15. Lineup with shrouds installed.

There will be one upper shroud per case.

OPTIONS

Optional Disconnect Installation

Optional disconnect shipped loose (inside case) and wired to condensing unit distribution block on site by installer.

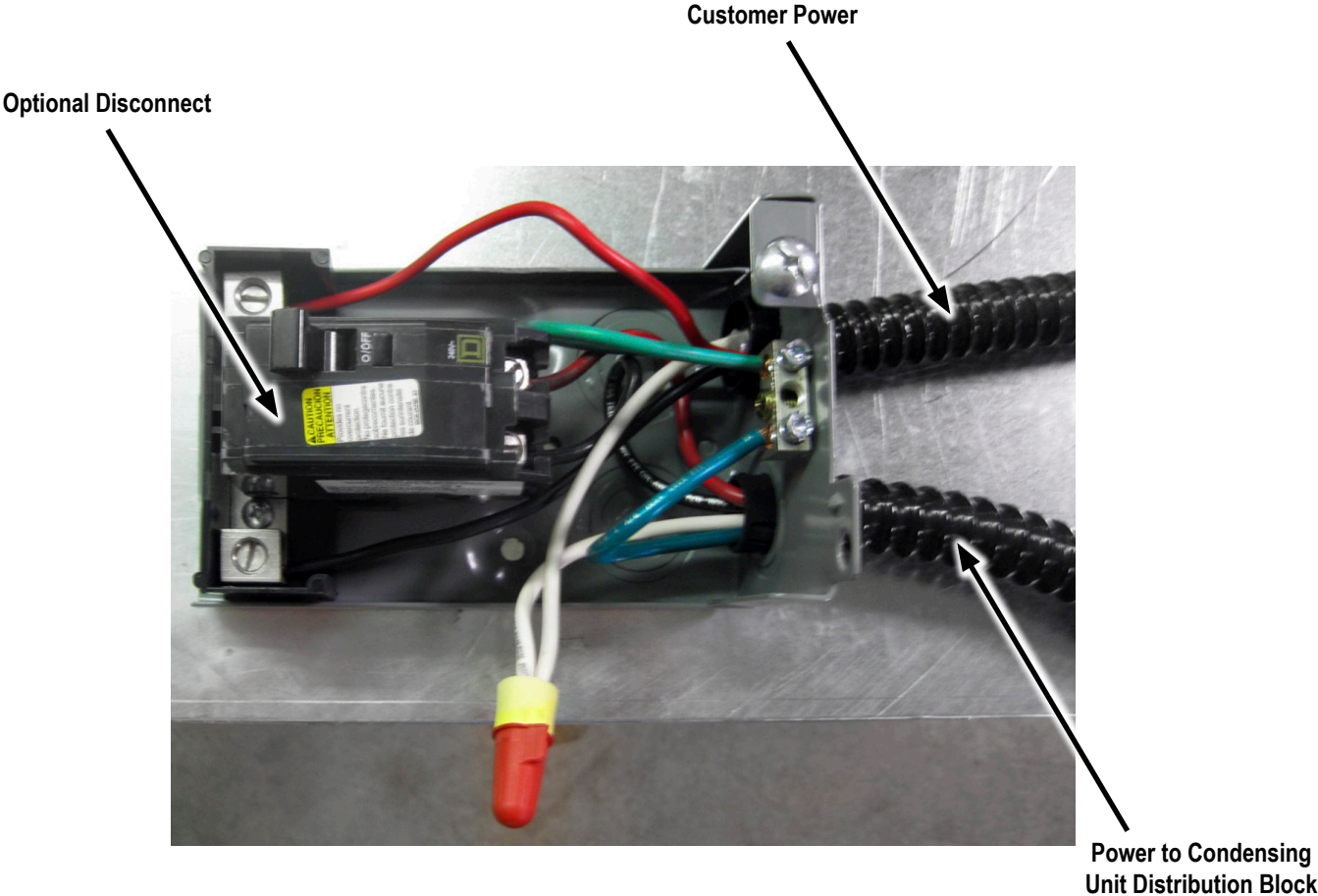

MANAGER'S EMERGENCY GUIDE

Hybrid™ Display Cases

Zero Zone medium and low temp Hybrid™ display cases have a built-in alarm system to alert you of problems with the operation of the case. In the event of a problem, an alarm will sound (a constant beeping noise) and the display will flash an error code. If this occurs:

1. Press and hold the “**Prg**” button on the display for 5 seconds to silence the alarm. The “**Prg**” button is in the upper left of the control. Doing so will silence the alarm for 60 minutes.
2. Identify the alarm code displayed on the screen. The FOUR most common alarm codes are listed below:
 - **E0** = case temperature probe error
 - **E1** = defrost temperature probe error
 - **HI** = high temperature inside the display case
 - **LO** = low temperature inside the display case**DEF** = case is in defrost (this is not an error code)
3. If the error code is an **E0** or an **E1**, then proceed to step #4; a qualified refrigeration technician is required to correct the situation. In the event of a high temperature alarm (**HI**), there is a chance that there is a simple fix for the problem:
 - a. Verify that a door is not accidentally held open. Sometimes products will fall off the shelves and prevent a door from fully closing.
 - b. Confirm that the case was not recently stocked with product. Holding one of the doors open for an extended period of time (as is the case when stocking) will raise the internal temperature and possibly set off the alarm.
 - c. Determine whether a defrost cycle has recently occurred. Following the defrost period, the case temperature may be warmer than usual.
 - d. Make sure proper airflow is not compromised by debris covering the balloon guard located at the front of each condensing unit on the top of each case behind the shroud. You will need to use a step ladder to check this. If possible, remove the item or debris blocking the balloon guard. If you are unable to easily remove the item or debris, call your service provider.Identifying and correcting any of these problems will return the case temperature to normal conditions.
4. If the source of the problem was not identified in step #3, a service request should be directed to your service provider immediately.



This image shows the controller at normal operation.



This image shows the controller during an alarm condition. This is the high temperature alarm code (HI). Other codes may also be displayed.
(See above for other codes)



For other technical support, please refer to
Zero Zone Installation & Operation Manuals
available on the Service page at:

WWW.ZERO-ZONE.COM

or contact the Zero Zone Service Department at:

800-247-4496

All specifications subject to change without notice.

