



Zero Zone





101B, 210X, ELM
Low Temp and Normal Temp
Installation & Service Manual

99-18544-S001_C



Copyright © 2011 by

ALL rights reserved. Information in this document is subject to change without notice. Companies, names and data used in examples herein are fictitious unless otherwise noted. No part of this document may be reproduced or transmitted in any form or by any means, electronic or mechanical, for any purpose, without express permission of Anthony Manufacturing Co., Inc.

Anthony products identified in this manual are designed and certified to meet  or  for safety, and  for sanitation standards.

European products meet  requirements.

Each customer is responsible for final site approval.

TABLE OF CONTENTS

- 1. PRELIMINARY CONSIDERATIONS FOR DOOR AND FRAME SERVICING PROCEDURES..... 5**
 - 1.1. Safety..... 5
 - 1.2. Tools 5
 - 1.3. Tips 5
- 2. PARTS PLACEMENT..... 6**
 - 2.1. Model 101B & ELM Door Parts Placement 6
 - 2.2. Model 210X Door Parts Placement 7
 - 2.3. Frame Width Data..... 8
 - 2.3.1. Model 101X, 210X, ELM 8
 - 2.3.2. Single-Door thru Five-Door Full Flanged Frames 8
 - 2.4. Model 101X Frame Parts Placement..... 9
 - 2.5. Optimax Pro 24V LED Lighting..... 10
 - 2.6. Optimax Pro 24V LED Approved Drivers 11
 - 2.6.1. 24V LED Driver (60-19910-0002) 11
 - 2.6.2. 24V LED Driver (60-20062-0001) 12
 - 2.7. Door and Frame Assembly Diagram 13
- 3. DOOR REMOVAL AND REVERSAL..... 14**
 - 3.1. Removing the Door Assembly from the 101X Frame..... 14
 - 3.2. Reversing the Door Swing 15
- 4. DOOR MAINTENANCE AND PARTS REPLACEMENT 19**
 - 4.1. Removing and Replacing the Door Gasket 19
 - 4.2. Removing and Replacing the Door Rail Plastic Cover 20
 - 4.3. Replacing the Door Handle 22
 - 4.4. Door Bumper Removal and Replacement..... 24
 - 4.5. Cylinder Lock Repair and Replacement..... 25
 - 4.6. Removing and Replacing the Torque Rod 27
 - 4.7. Removing the Hold-Open Assembly 28
 - 4.8. Replacing the Hold-Open Assembly..... 29
 - 4.9. Hold-Open Assembly Standard and Reverse Geometry..... 29
 - 4.9.1. Standard Geometry 30
 - 4.9.2. Reverse Geometry 30
 - 4.10. Door Heater Wire Replacement 31
 - 4.10.1. Splicing wire ends with solder and shrink tubing 33
 - 4.11. Removing and Replacing the Hinge Pin..... 34
 - 4.12. Glass Pack Replacement Procedures..... 35

4.13. Ordering Replacement Doors 39

5. REPLACEMENT DOOR INSTALLATION 40

5.1. Installing the Door Assembly into the 101X Frame 40

5.2. Torque and SAG Adjustment..... 42

6. FRAME MAINTENANCE & PARTS REPLACEMENT 43

6.1. Torque Replacement 43

6.2. Power Receptacle Replacement 44

6.3. Frame Heater Wire Replacement (see Section 8 for Wiring Diagrams) 46

6.4. Driver Replacement 47

6.5. Frame Reassembly..... 49

7. TROUBLESHOOTING..... 50

8. DOOR & FRAME ELECTRICAL SPECIFICATIONS..... 52

8.1. Typical Heater Wire and Lighting Wiring Diagrams..... 52

8.1.1. Zero Zone 101X, 210X and ELM LT/NT Frames 52

8.1.2. Zero Zone Low Energy 101X, 210X and ELM LT Frames..... 53

8.1.3. Zero Zone 101X, 210X and ELM LT Frames 53

8.1.4. Zero Zone 101X and 210X NT Frames..... 54

8.2. Anthony Door Model 101 Optimax Pro 24 Wiring Diagram & Orientation..... 55

8.3. Dew Point Chart..... 58

9. SUPPLEMENTAL HANDLE REPLACEMENT INSTRUCTIONS 59

9.1. Preliminary Considerations..... 59

9.2. Perform the following steps to remove the door handle mounting fasteners. 59

10. REVISION HISTORY PAGE..... 63

1. PRELIMINARY CONSIDERATIONS FOR DOOR AND FRAME SERVICING PROCEDURES

1.1. Safety

Proper safety equipment includes:



Safety Glasses



Work Gloves



Work Shoes



NOTE: Turn off all electrical power prior to beginning work on the door or on any electrical equipment. Use extra caution when working with or around the door glass package.

NOTE: Do Not use power tools for the following procedures.

1.2. Tools

Tools required for this procedure include:

- #2 Phillips-head screwdriver
- Needle-nose pliers
- 7/16" and 1/2" Hand Wrench
- Wire stripper and cutter
- Heat Gun
- Flat-head screwdriver
- Rubber or plastic mallet
- 5/32" Hex Key
- Soldering iron
- Razor Knife

1.3. Tips

- Complete replacement of wire assemblies is recommended whenever required. Splice wires only if necessary, using proper materials: such as electrical tape, wire nuts, flux core solder and heat shrink.
- Apply liquid soap to rail plastic covers and gaskets upon installation to facilitate insertion into mounting grooves.
- Keep doors and frames clean for product efficiency. This can also help reduce energy consumption and potential health hazards.
- Whenever binding gasket or plastic parts, use food grade silicone.
- Whenever replacing fluorescent lamps, always replace lamp covers as well.
- Always use the correct tool for the job to be performed. This ensures proper installation and minimizes safety risks.
- If there is any doubt about the work to be performed, consult with a certified technician or Anthony representative.
- Preventative maintenance is recommended to ensure product longevity.

2. PARTS PLACEMENT

2.1. Model 101B & ELM Door Parts Placement

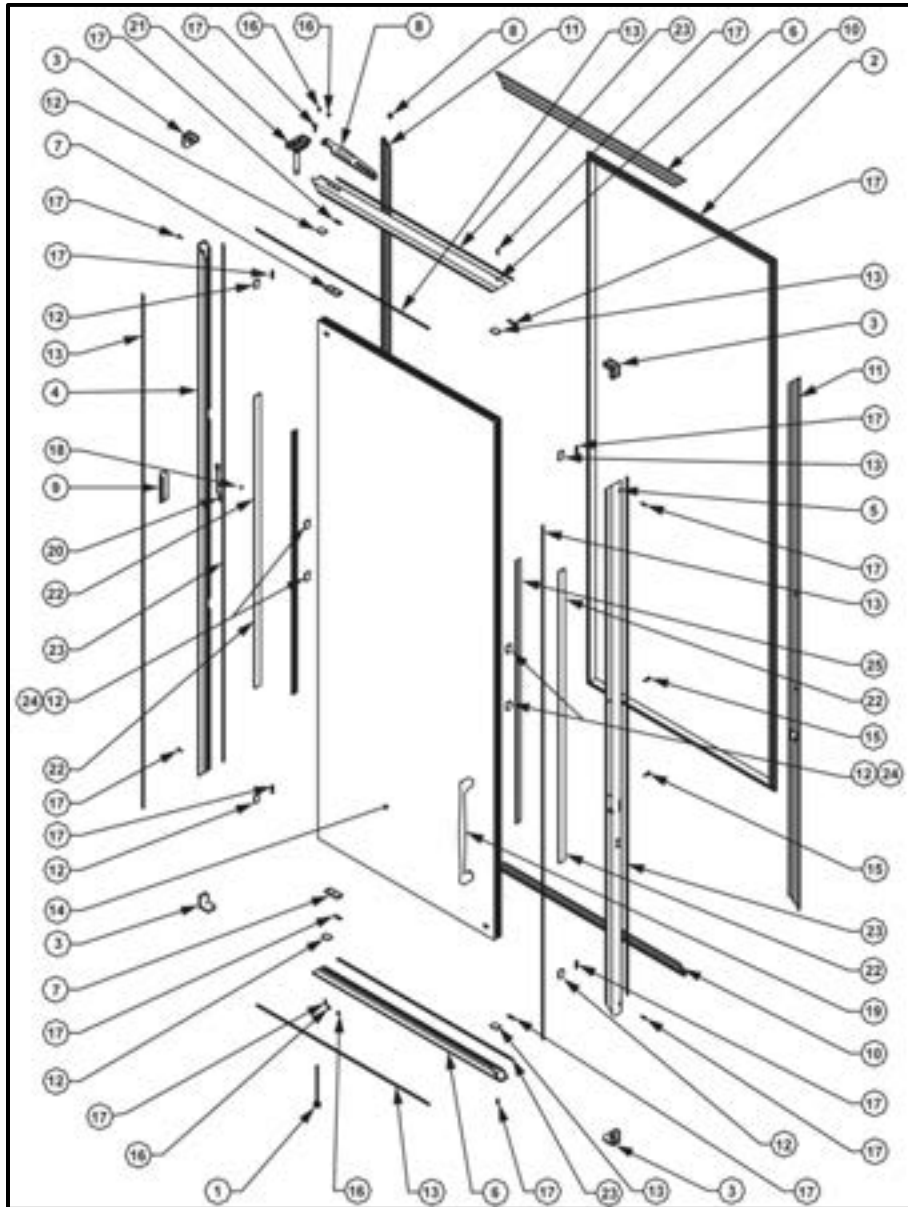

Description	Description	Description
1. Torque Rod Assembly	10. Top & Bottom Rail Cover	19. Slimline Handle
2. Gasket with Magnet	11. Side Rail Covers	20. Ground Wire Assembly
3. Corner Pieces	12. Wedge Spacer	21. Hinge Pin
4. Door rail (Hinge Side)	13. Vinyl Glazing	22. Sealant
5. Door Rail (Handle Side)	14. Glass Pack Assembly	23. Foam Mounting Tape
6. Top & Bottom Rail	15. 10-28 x 5/8" Screws	24. 3M Hot Melt Sealant
7. Hold Open Backing Plate	16. 3/16" x 3/8" x 3/8" Rivets	25. Door Handle Rail Insert
8. Hold Open Fork & Spacer	17. 8-32 x 5/8" Screws	
9. Access Hole Cover	18. #42 Steel Rivets	

2.2. Model 210X Door Parts Placement

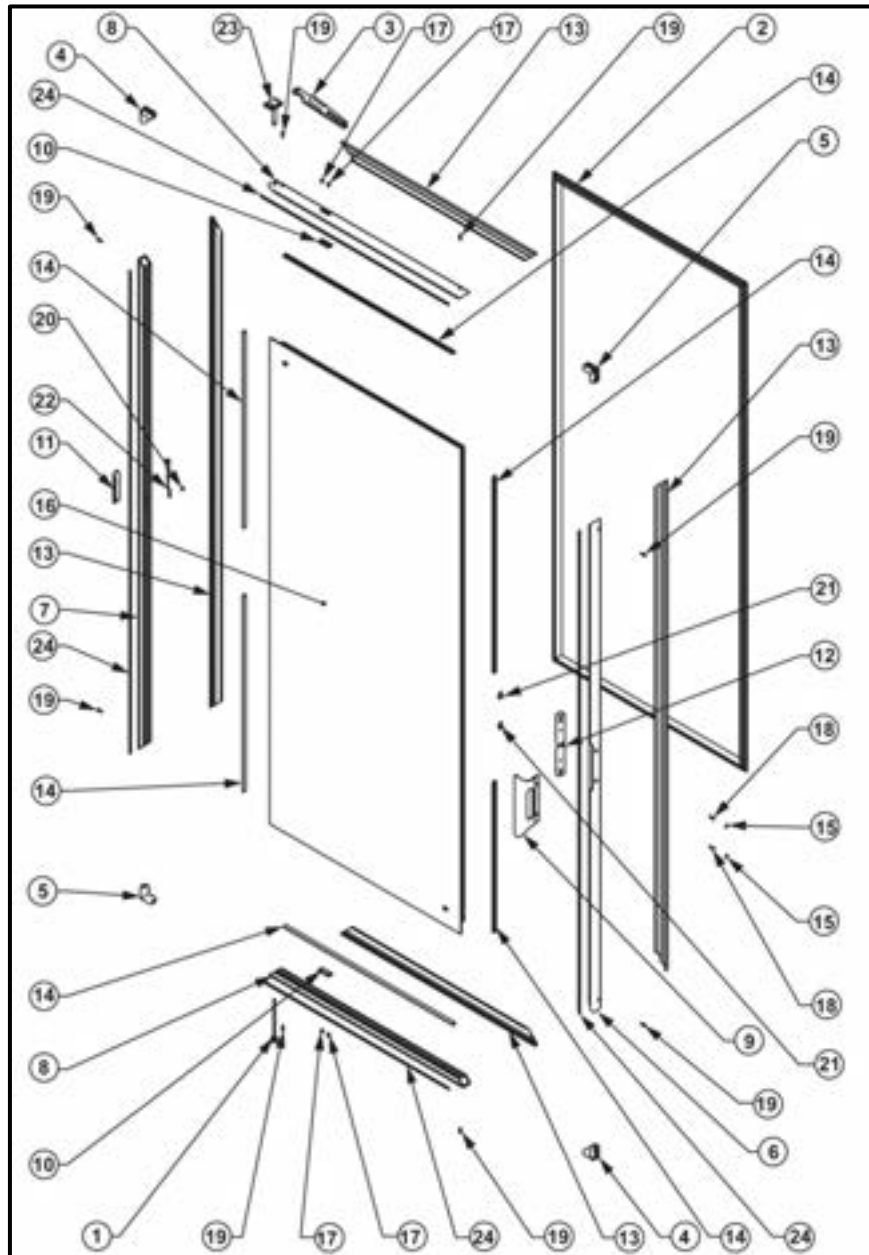

Description	Description	Description
1. Torque Rod Assembly	10. Plate Backing	19. 8-32 x 5/8" Black Screw
2. Gasket with Magnet	11. Access Hole Cover	20. 6-32 x 3/16" Screw
3. Hold Open Fork	12. Handle Mounting Block	21. Weld Nut
4. Left Hand Corner Piece	13. Plastic Cover	22. Heater Wire Plug Assembly
5. Right Hand Corner Piece	14. Door Rail Filler	23. Hinge Pin
6. Handle Rail	15. Cap	24. Foam Tape
7. Hinge Rail	16. Door Glass Package	
8. Top Rail	17. 3/16" x 3/8" Steel Rivet	
9. Door Handle	18. 8-32 x 5/8" Zinc Screw	

2.3. Frame Width Data

2.3.1. Model 101X, 210X, ELM

Catalog Size	Actual Door Size	Number of Doors Per Frame Section				
		1-Door	2-Door	3-Door	4-Door	5-Door
24"	23-3/16"	24-7/8"	48-5/8"	72-3/8"	96-1/8"	119-7/8"
26"	26-3/8"	28-1/16"	55"	81-15/16"	108-7/8"	135-13/16"
28"	28-3/8"	30-1/16"	59"	87-15/16"	116-7/8"	145-13/16"
30"	29-7/8"	31-9/16"	62"	92-7/16"	122-7/8"	153-5/16"

Finished Frame Net Opening Width – Endless Mullion

Catalog Size	Actual Door Size	Number of Doors Per Frame Section				
		1-Door	2-Door	3-Door	4-Door	5-Door
24"	23-3/16"	25-1/8"	48-7/8"	72-5/8"	96-3/8"	120-1/8"
26"	26-3/8"	28-5/16"	55-1/4"	82-3/16"	109-1/8"	136-1/16"
28"	28-3/8"	30-5/16"	59-1/4"	88-3/16"	117-1/8"	146-1/16"
30"	29-7/8"	31-13/16"	62-1/4"	92-11/16"	123-1/8"	153-9/16"

Finished Frame Net Opening Width – Full Flange

2.3.2. Single-Door thru Five-Door Full Flanged Frames



ONE-DOOR FRAME

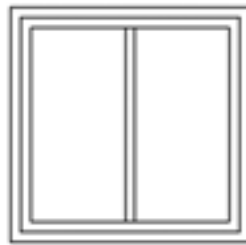

TWO-DOOR FRAME



THREE-DOOR FRAME

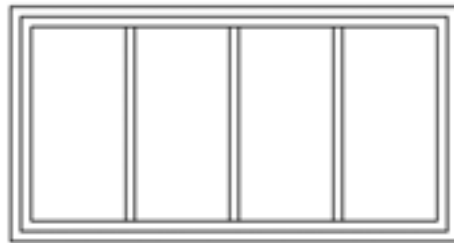

FOUR-DOOR FRAME

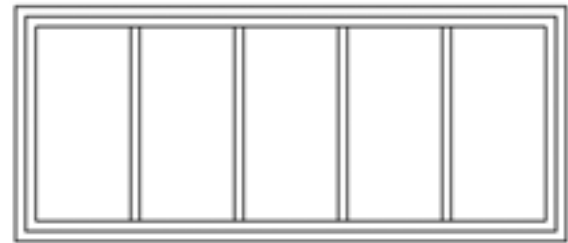

FIVE-DOOR FRAME

2.4. Model 101X Frame Parts Placement

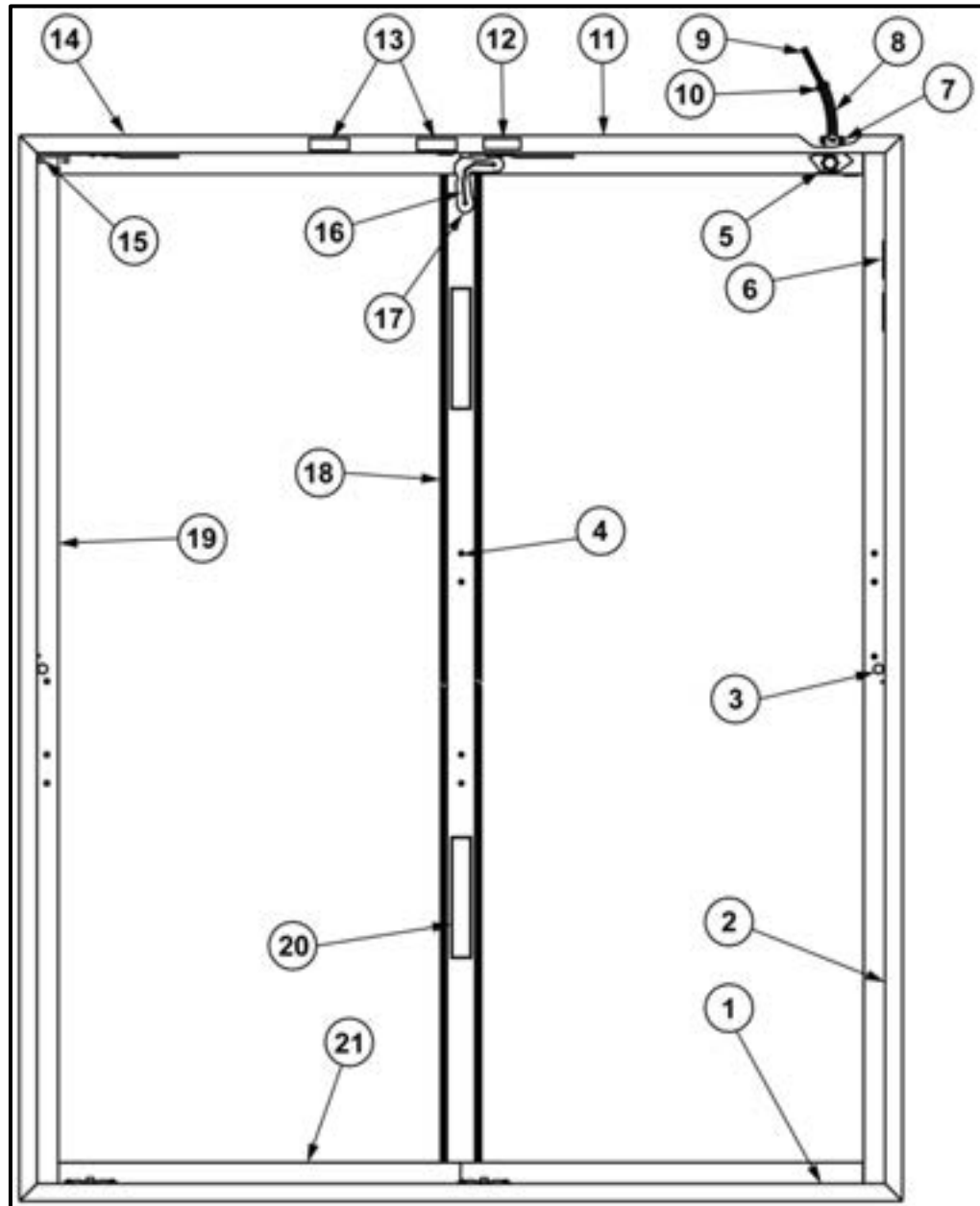

NOTE: Zero Zone frame wires exit at the bottom right of the frame.

Description	Description	Description
1. Sill Frame	8. Flexible Aluminum Conduit	15. Hinge Pin Gib
2. End Frame	9. Heater & Lighting Wiring	16. Ground Jumper Assembly
3. Black Female Cap Plug	10. Screw-In Flexible Connector	17. 6-32 x 3/16" Screw
4. 8-18 x 0.219 SMS Screw	11. Flanged Frame Header	18. Center Mullion Contact Plate
5. Steel Lock Nut	12. Connection Diagram Label	19. End Frame Contact Plate
6. Warning & ID Labels	13. Brand Labels	20. Driver
7. 90° Flex Connector	14. Warning Label	21. Bottom Contact Plate

2.5. Optimax Pro 24V LED Lighting

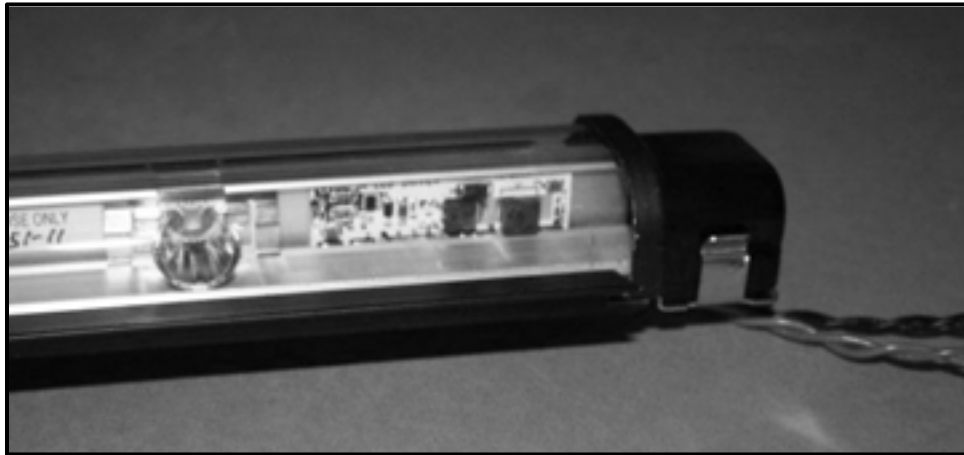

Center Fixture (60-18898-xxxx) High Power (60-19295-xxxx) Low Power

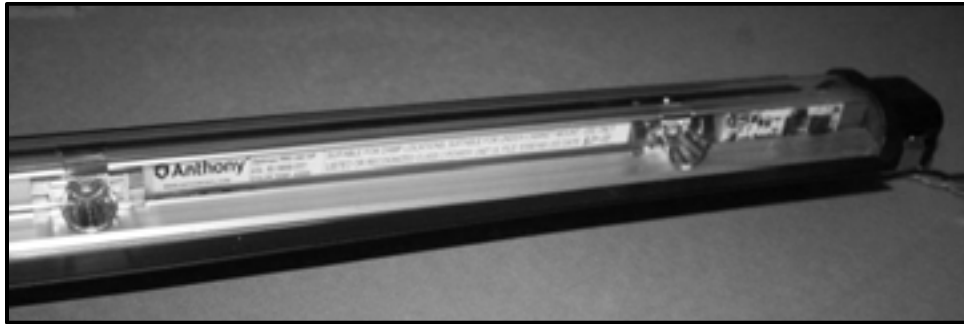

End Fixture (60-18899-xxxx) High Power (60-19296-xxxx) Low Power

Description	Center Fixture (4000K)	Center Fixture (3500K)
72" Fixture (High Power)	60-18898-0002	60-18898-3002
60" Fixture (High Power)	60-18898-0001	60-18898-3001
54" Fixture (High Power)	60-18898-0008	60-18898-3008
48" Fixture (High Power)	60-18898-0003	60-18898-3003
Description	End Fixture - Left (4000K)	End Fixture - Left (3500K)
72" Fixture (High Power)	60-18899-0002	60-18899-3002
60" Fixture (High Power)	60-18899-0001	60-18899-3001
54" Fixture (High Power)	60-18899-0008	60-18899-3008
48" Fixture (High Power)	60-18899-0003	60-18899-3003
Description	End Fixture - Right (4000K)	End Fixture - Right (3500K)
72" Fixture (High Power)	60-18899-1002	60-18899-4002
60" Fixture (High Power)	60-18899-1001	60-18899-4001
54" Fixture (High Power)	60-18899-1008	60-18899-4008
48" Fixture (High Power)	60-18899-1003	60-18899-4003

Description	Center Fixture (4000K)	Center Fixture (3500K)
72" Fixture (Low Power)	60-19295-0002	60-19295-3002
60" Fixture (Low Power)	60-19295-0001	60-19295-3001
54" Fixture (Low Power)	60-19295-0008	60-19295-3008
48" Fixture (Low Power)	60-19295-0003	60-19295-3003
Description	End Fixture - Left (4000K)	End Fixture - Left (3500K)
72" Fixture (Low Power)	60-19296-0002	60-19296-3002
60" Fixture (Low Power)	60-19296-0001	60-19296-3001
54" Fixture (Low Power)	60-19296-0008	60-19296-3008
48" Fixture (Low Power)	60-19296-0003	60-19296-3003
Description	End Fixture - Right (4000K)	End Fixture - Right (3500K)
72" Fixture (Low Power)	60-19296-1002	60-19296-4002
60" Fixture (Low Power)	60-19296-1001	60-19296-4001
54" Fixture (Low Power)	60-19296-1008	60-19296-4008
48" Fixture (Low Power)	60-19296-1003	60-19296-4003

2.6. Optimax Pro 24V LED Approved Drivers

2.6.1. 24V LED Driver (60-19910-0002)



Specifications:

- Max. Output Power: 100W
- Input Voltage: 100V – 277VAC
- Output Current: 4.10A
- Output Voltage: 24VDC
- Min. Power Factor: 0.9
- IP rating: IP64
- Operating Temperature: -40° to 60°C max
- Isolation: Class 2

2.6.2. 24V LED Driver (60-20062-0001)



Specifications:

- Max. Output Power: 90W max
- Input Voltage: 100V - 277VAC
- Output Current: 3.75A max
- Output Voltage: 24VDC
- Min. Power Factor: 0.9
- IP rating: IP67
- Operating Temperature: -20°to 60°C
- Isolation: Class 2

2.7. Door and Frame Assembly Diagram

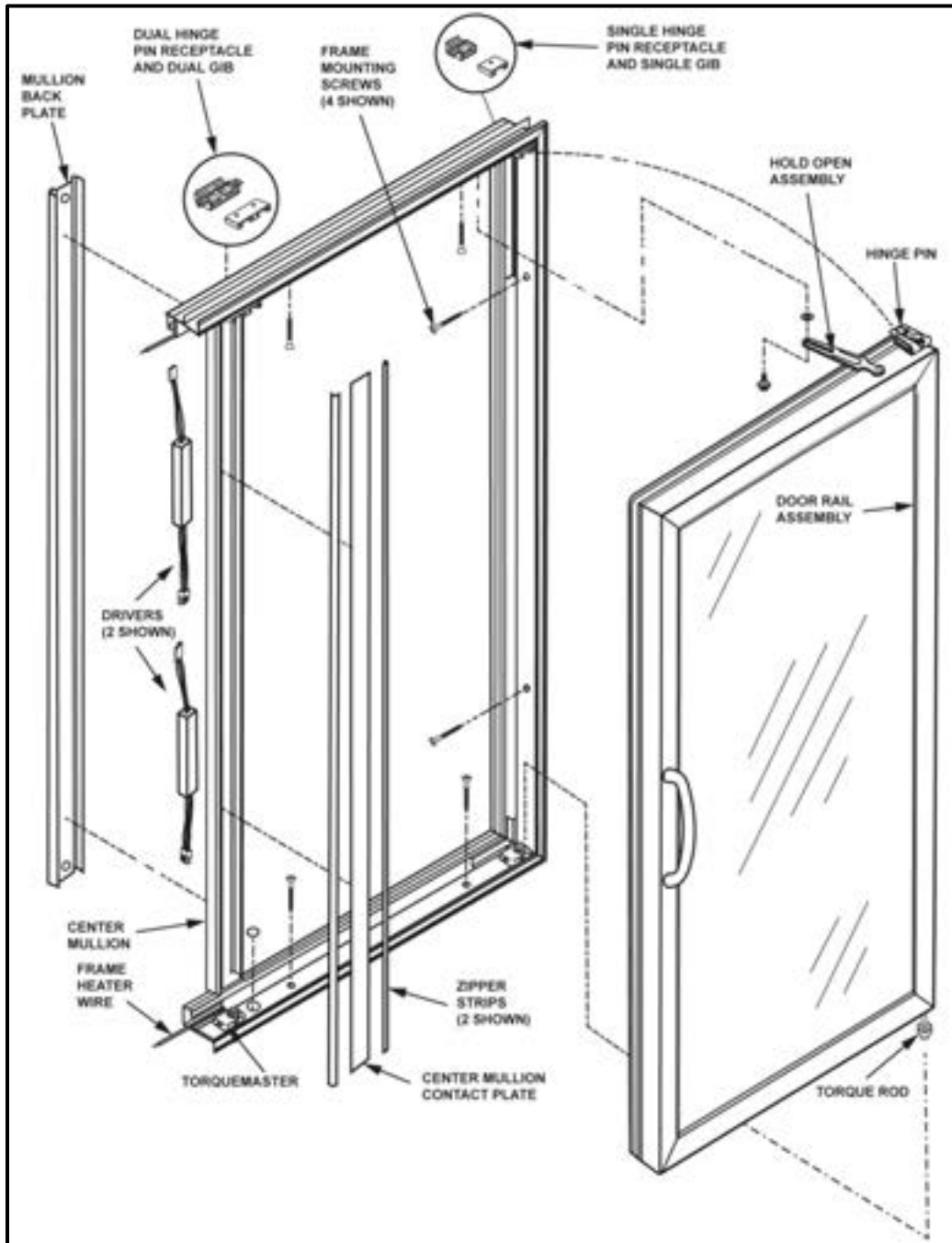

3. DOOR REMOVAL AND REVERSAL

3.1. Removing the Door Assembly from the 101X Frame

1. Using a flat-head screwdriver, loosen the tension on the door by turning the adjustment screw, located on the front of the torquemaster, to the right or clockwise.

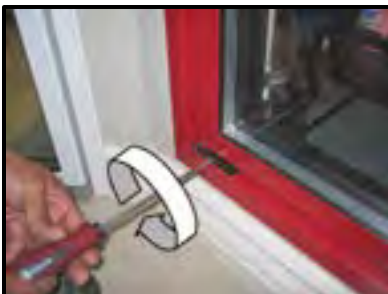

2. Test the door by opening it, and confirm that the torque tension does not retract the door from open position.
3. If tension remains, continue adjusting the torquemaster until all tension has been removed from the door.
4. Open the door to access the hold open device. Loosen and remove the hold-open bolt, using a phillips-head screwdriver.



5. Remove the hold open stud using a 7/16" hand wrench.
6. Retract the door to a near-closed position.
7. Insert the top half of the needle-nose pliers into the grip-hole, located in the hinge pin spring-clip, and the bottom half of the pliers beneath the hinge pin shroud.



8. Squeeze the pliers to clamp down on the hinge pin spring clip, allowing the clip to release the hinge pin from the receptacle gib of the frame, while simultaneously pulling the top of the door away from the frame. This will release and pull the hinge pin out of the hinge pin receptacle and gib.

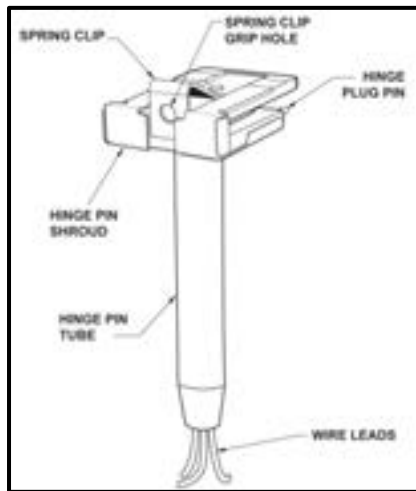

Hinge Pin Assembly



9. Continue pulling the top of the door assembly away from the frame until the top door rail clears the frame.
10. Lift and remove the door from the torquemaster and carefully set the door aside.

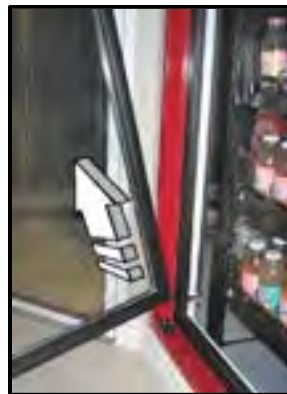

3.2. Reversing the Door Swing

1. Using a flat-head screwdriver, loosen the torquemaster from its mount by turning the center mounting screw counter-clockwise less than one-half (1/2) of a turn.



Remove the Torquemaster, exposing the mounting hole in the bottom frame rail.

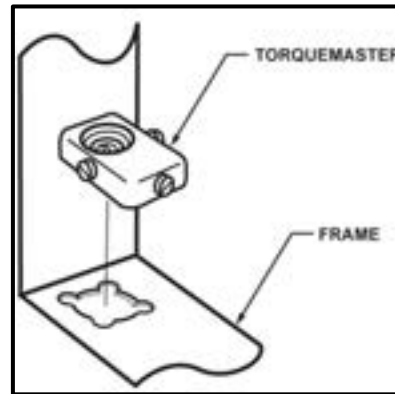

2. Locate the mounting hole at the opposite side of the door opening.
3. Using the flat-head screwdriver, carefully pry underneath the plug cap and remove it.



4. Place the Torquemaster on the newly opened mounting hole, aligning the flanged corners of the mounting tabs.



5. Insert the Torquemaster mounting tabs onto the mounting hole with the hollow end of the Torquemaster against the door frame.
6. Confirm that the mounting flanges on the bottom of the torquemaster align with the corner mounting slots of the mounting hole in the frame.
7. Using a flat-head screwdriver, turn the Torquemaster mounting set-screw clockwise, for 1/2 a turn, to tighten the mount and lock it in place. Confirm that the torquemaster mounting is flush with the door frame.

- Using a 7/16" open-ended hand wrench, loosen and remove the hold-open detent bolt from the top frame rail.



- Relocate and install the hold-open shoulder bolts into the opposite hold-open mount of the same door frame.



- If installing in Reverse Geometry, insert the hold-open stand-off into the frame header and install the detent bolt into the top of the door. Tighten each with a 7/16" open-ended hand wrench.



- Open the access portal to the hinge pin wire connections in the rail on the hinge side of the door assembly.

12. Disconnect the Hot, Neutral and Ground wires of the hinge pin from the heater wire circuit and the ground terminal.



13. Loosen and completely remove the hinge pin assembly from the top door rail.

NOTE: Refer to “Removing and Replacing the Hinge Pin” for complete replacement procedures.

14. Using a plastic mallet and a flat-head screwdriver, remove the torque rod from the bottom of the door assembly.



NOTE: Refer to “Removing and Replacing the Torque Rod” for complete Torque Rod replacement instructions.

15. Swap placement of the Hinge Pin and Torque Rod to the other's original mounting hole in the door assembly hinge side rail.
16. Reinstall the hinge pin and the torque rod completely into the ends of the door assembly hinge rail.
17. If necessary, lightly tap on the hinge pin and torque rod with a plastic or rubber mallet until each is fully seated into the top and bottom of the door.
18. Reconnect the hinge in wires and confirm that all connections are secure.
19. Check and confirm torque rod and hinge pin are correctly and completely installed.
20. Reinstall the door into the frame.

NOTE: Refer to “REPLACEMENT DOOR INSTALLATION” for complete door installation instructions.

4. DOOR MAINTENANCE AND PARTS REPLACEMENT

4.1. Removing and Replacing the Door Gasket

1. Begin removing the door gasket by lifting one corner of the gasket out of the groove.



2. Carefully pull the gasket out of the groove in the plastic rail covers.



NOTE: The gasket is composed of soft materials with welded miter joints. Use extra care when manually extracting the gasket from the rail grooves to prevent damaging it as well as the plastic rail.

3. Align the two corners of the replacement gasket onto the top mitered corners of the plastic cover, with the gasket arrow facing the door rail and cover.
4. Press the gasket arrow into the groove in the center of the plastic cover corners until the edges of the gasket arrow catch and the arrow is initially inserted into the groove of the plastic cover.
5. Align the bottom two gasket corners with the bottom mitered corners of the plastic covers, aligning the gasket arrow with the groove in the plastic cover and press the corners into the groove until the arrow is fully inserted.

6. Press the gasket firmly against the top plastic cover, sliding from side to side and applying full pressure against the gasket, forcing the gasket arrow into the groove in the plastic top cover.

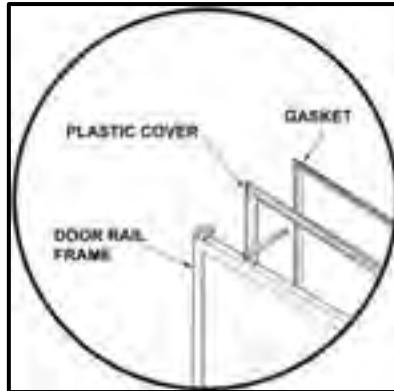

7. Continue pressing the gasket arrow into the grooves of the remaining plastic cover, around the entire door rail perimeter (if necessary, a plastic or rubber mallet can be used to facilitate the arrow into the groove by applying a swift stroke onto the gasket- DO NOT damage the gasket or the glass).
8. Confirm that the entire gasket arrow has been completely inserted into the groove of all four plastic rail covers.

4.2. Removing and Replacing the Door Rail Plastic Cover

1. Insert the end of a slot head screwdriver in between two plastic cover ends at the corner miter.



2. Carefully twist the screwdriver to loosen the corner of the plastic cover lip from the door rail.
3. Continue to pry the plastic cover from the door rail until the entire end of the plastic rail is disengaged.



4. Pull the plastic cover up and out of door rail grooves until the entire plastic cover is removed from the door rail.



5. Repeat step 2 through step 4 to loosen and remove the three remaining plastic covers.
6. To install the new, replacement plastic covers, begin by aligning the replacement plastic cover evenly onto the door rail.
7. Insert the outer edge of the plastic cover into the outside groove of one of the door rails.



8. Push the plastic cover down and inward, toward the center of the door.
 9. Slide along the entire length of the plastic cover while firmly applying pressure against it. Continue applying pressure along the length of the entire door rail, inserting both the outside lip and the inside lip into the door rail grooves simultaneously.
- NOTE:** Carefully tap the plastic cover with deliberate strokes, using a plastic or rubber mallet outward and away from the glass. This may help seat the lips of the plastic cover into the grooves of the door rails.
10. Check the entire plastic cover and confirm that both the inside and outside lips are fully inserted into the door rail grooves.
 11. Repeat this procedure, aligning each mitered corner, with the remaining plastic covers until all four plastic covers are properly installed onto door rails.
 12. Confirm that each plastic cover is fully installed and the mitered corners properly aligned.

4.3. Replacing the Door Handle

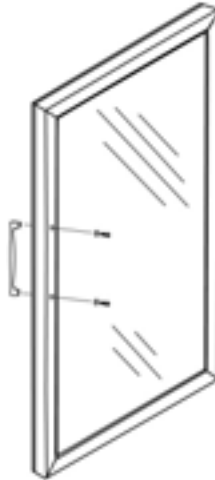

1. Carefully remove the door gasket installed into the plastic cover over the door rail in which the door handle is installed (leaving the gasket on the remaining door rail assembly for easy reassembly is recommended).
2. Insert the end of a slot head screwdriver in between two plastic cover ends at the corner miter of the plastic cover over the door rail with the handle.
3. Twist the screwdriver to loosen the corner of the plastic cover lip from the door rail grooves.
4. Pry the plastic cover from the handle side of the door rail until the entire end of the plastic rail is disengaged and remove the entire plastic cover from the door rail with the handle.
5. Insert a 5/32" hex key or Allen Wrench into the door rail openings and into the screw head securing the door handle.
6. Turn the screw counter-clockwise to loosen and remove it.



NOTE: In the event that the screw heads are obstructed, refer to product notification for instructions detailing the removal of the obstruction. Refer to "Appendix B-1: DOC IN-0002 SUPPLEMENTAL HANDLE REPLACEMENT INSTRUCTIONS for more information.

7. Repeat step 1 thru step 6 with the second mounting screw and remove the handle assembly from the door.
8. Insert mounting screws into mounting holes until the ends of the screw protrude through the mounting holes.



9. Insert the hex key or Allen Wrench into screw head.
 10. Hold the Handle mounting holes against the protruding screw ends.
- NOTE:** Make sure the handle is configured with the screws mated with the correct mounting holes in the handle.
11. Turn the first screw clockwise until the threads catch.
 12. Repeat the last step to connect the remaining screw and handle mount.
 13. Tighten each mounting screw.



14. Confirm the handle is secure and flush-mounted to the surface of the door rail and reassemble the door.

4.4. Door Bumper Removal and Replacement

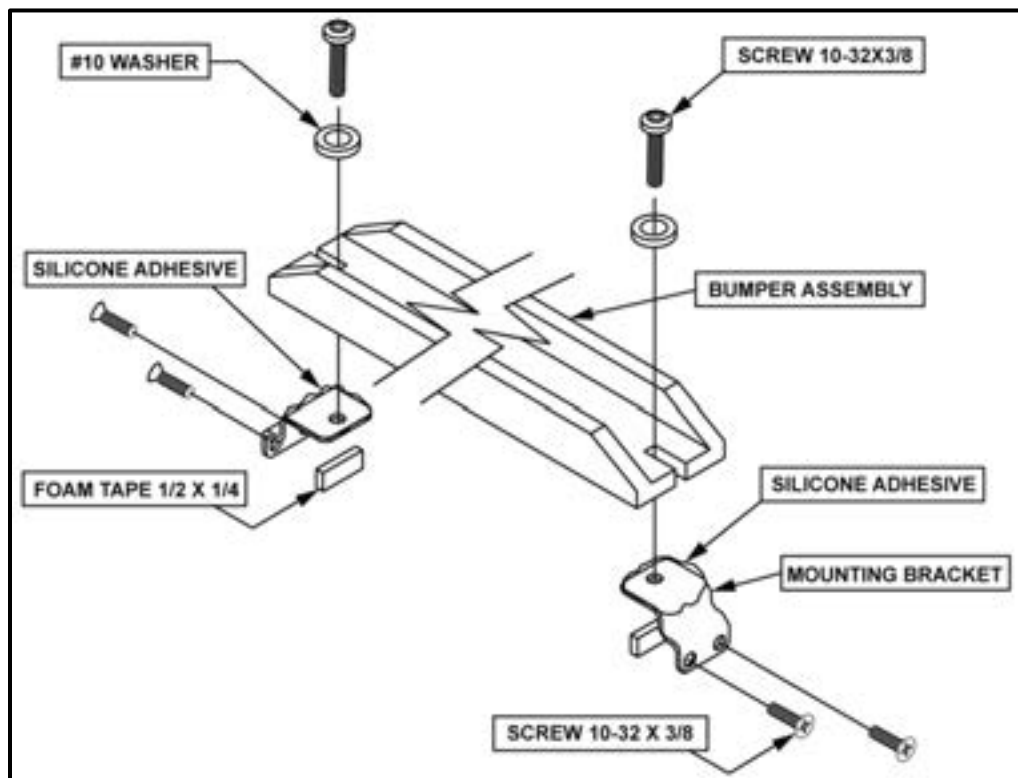

1. Using a phillips-head screwdriver, loosen and remove both self-threading screws and washers at each end of the bumper assembly. Remove the bumper (leaving the gasket on the remaining door rail assembly for easy reassembly).
2. If necessary, remove bumper mounting brackets.
 - Remove plastic covers from the longer, side door rails.
 - Using a razor knife, carefully cut the silicone adhesive.
 - Loosen and remove bracket mounting screws.
 - Carefully remove mounting brackets.
3. Replace door bumper assembly mounting brackets.
 - Completely clean each bracket of silicone adhesive residue.
 - Apply a generous amount of fresh silicone adhesive to the outside of each mounting bracket.
 - Insert new self-threading 10-32 X 3/8" screws into the bracket mounting holes and into the door rail mounting holes.
 - Using a phillips-head screwdriver, turn the screws clockwise until all four screws are tightened and both mounting brackets are securely fastened.
 - Apply silicone adhesive along the seams of each bracket to ensure a proper seal.
 - Allow for silicone adhesive to fully cure.

4. Replace the plastic covers to the door rails (refer to plastic cover replacement procedures).
5. Replace bumper assembly to the door.
6. Align the mounting holes in the bumper assembly with the holes in the mounting brackets.
7. Insert new self threading 10-32 x 3/8" screws into the bumper assembly mounting holes.
8. Using a phillips-head screwdriver, turn the screws clockwise until each screw is tight and the bumper assembly is securely mounted.
9. Confirm that the bumper assembly is securely mounted to the door.

4.5. Cylinder Lock Repair and Replacement

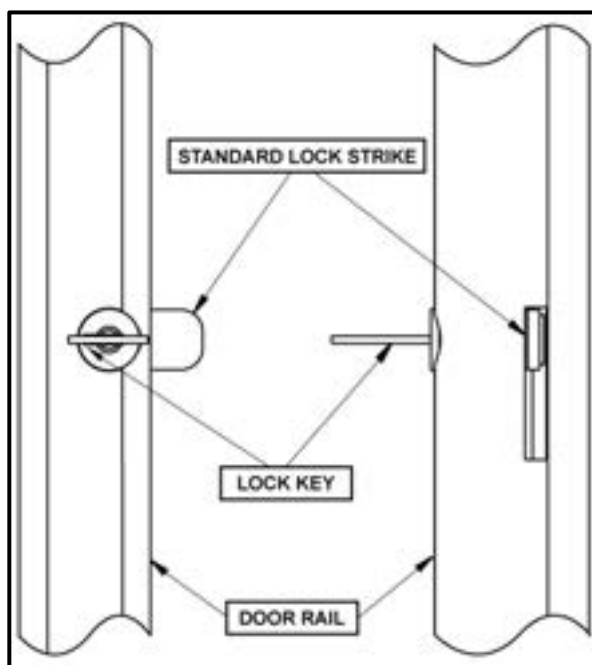
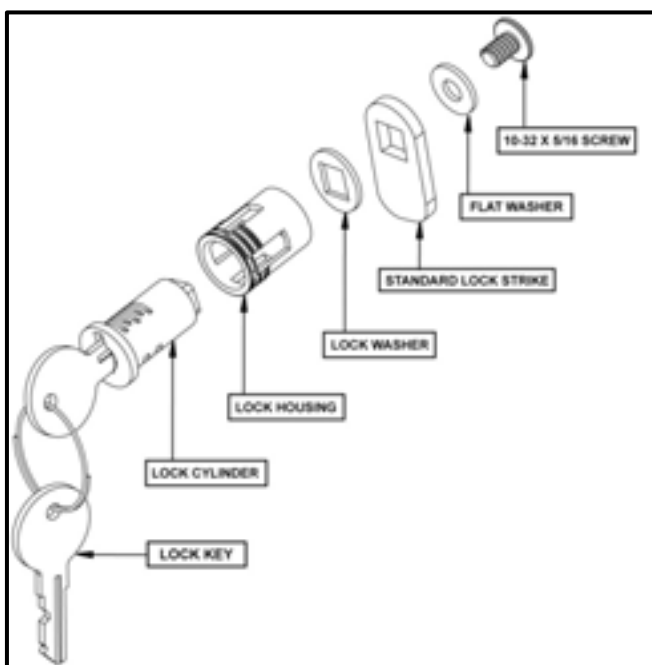

Cylinder Lock Installation

1. Remove gasket from door rail containing the lock (leaving the gasket on the remaining door rail assembly for easy reassembly).
2. Remove plastic cover from the door rail containing the lock assembly to expose access to the lock mount.



3. Insert a large phillips-head screwdriver into the lock access in the back of the door rail.

NOTE: Once the lock screw has been removed, the screw washers and lock latch will come loose. Be certain that these components are secure prior to the removal of the lock screw, or they may become lost if dropped inside of the door rail.



4. Turn the lock screw counter-clockwise to loosen the screw.
5. Carefully remove the screw, lock washers and lock strike from the back of the lock assembly.



6. If necessary, replace the strike.



7. Remove the lock assembly, out from the lock housing and through the front of the door rail.
8. Replace lock assembly into housing inside rail.
9. Replace the strike washer, strike, lock washer and screw to the rear of the lock assembly and assemble in the correct order. Be certain that the strike is fully and correctly seated onto the end of the cylinder.

10. Turn lock screw clockwise to catch the threads and tighten the screw completely. **DO NOT OVER-TIGHTEN.**



11. Test lock and confirm that it works properly.
12. Replace the plastic cover and gasket (refer to plastic cover and gasket replacement instructions).

4.6. Removing and Replacing the Torque Rod

1. Carefully place a flathead screwdriver between the door rail and the washer beneath the torque rod.



2. Dislodge the torque rod from its mount by pushing on the torque rod or tap it loose using a plastic or rubber mallet. **DO NOT** use a steel-headed hammer.



NOTE: Use caution when striking any tool with another tool. **DO NOT** use excess force when striking the screwdriver and potentially damaging the door.

3. Continue to carefully tap the torque rod, if necessary, until the torque rod and rod end disengage.
4. Carefully pull the torque rod assembly completely out the door rail.

5. Reverse the process to re-install the torque rod assembly into the door rail.
 - Insert torque rod into the bottom of the door until it is fully seated.
 - If required, tap the torque rod assembly into the door rail using a plastic or rubber mallet, until the torque rod is fully seated into the door rail socket.



4.7. Removing the Hold-Open Assembly

1. Remove screws from the hold-open standoffs, which are located on the door rail and frame.



2. Remove the hold open standoffs and discard them.
3. When replacing the hold-open arm, reverse step 1 by inserting the screw through the mounting hole in the arm and tightening it into the frame mounting hole using the #2 phillips head screwdriver.



*** Picture for orientation & reference only. Actual Hold-open assembly may differ from item shown.**

4.8. Replacing the Hold-Open Assembly

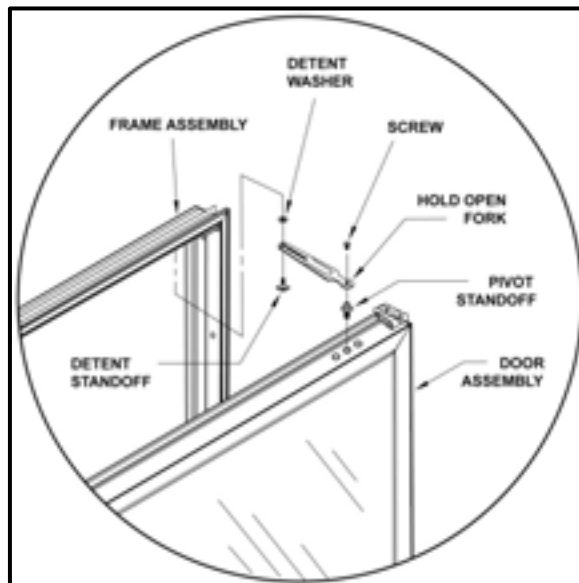

1. Insert the pivot standoff into door. Add Loctite #271 to threads. Torque to 100 in/lb.
2. Place the pivot hole of the new hold open over the pivot standoff that is closest to the hinge pin.
3. Retain with a new truss head screw and torque to 16 in/lb (approximately #2 clutch setting on a professional screw gun).
4. Remove the vinyl cap from the detent bolt.
5. Insert the bolt up thru the hold open slot and thru the detent spacer (flat side against frame).
6. Add loctite #271 to threads. Use a 7/16 hex wrench and torque into frame to 100 in/lb.
7. Add small amount of grease to detent surface.
8. Insure the truss head screw is seated on the end of the standoff and not the hold open.

4.9. Hold-Open Assembly Standard and Reverse Geometry

The 101B, 210X and the ELM models utilize reverse geometry for the Hold-Open assembly mounting configuration.

Reverse geometry of the Hold-Open mount has the same assembly configuration as the standard geometry. The difference with reverse geometry is that the hold open fork and the mounting hardware are reversed.

4.9.1. Standard Geometry

The Hold-Open fork slot, the Detent Standoff and the Detent Washer are mounted up, into the frame header rail. The fork pivot hole, along with the pivot standoff and pivot screw, is mounted down into the top rail of the door frame.

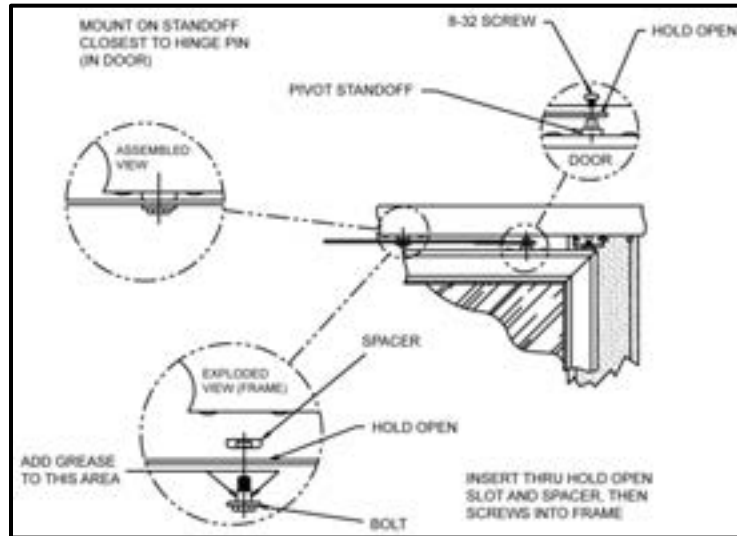

4.9.2. Reverse Geometry

The fork pivot hole, along with the pivot standoff and the pivot screw are mounted up, into the frame header rail. Conversely, the Hold-Open fork slot, the Detent Standoff and the Detent Washer are mounted down into the top rail of the door frame.

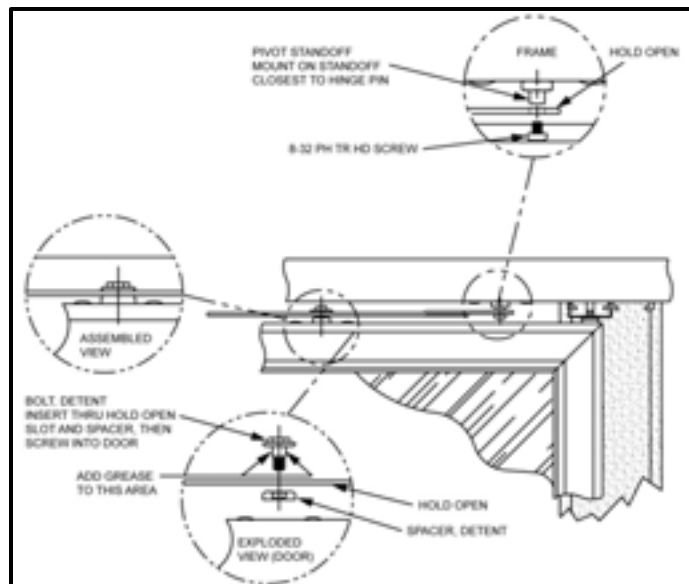

The same installation specifications are applicable to reverse geometry mounting procedures. Refer to this section as well as the Hold-Open removal and replacement sections for basic installation procedures and mounting specifications of the Hold-Open assembly.

4.10. Door Heater Wire Replacement

1. Remove door assembly from the frame (refer to door removal instructions).
2. Remove door gasket (refer to door gasket removal section for gasket removal procedure).
3. Remove plastic cover from all door rails (refer to plastic cover removal section for the removal procedure).
4. Using a small, flat-head screwdriver, remove the access cover from the frame to access the wiring (as with the plastic frame cover).



NOTE: Use caution when using a metal or edged tool to remove the heater wire, to avoid damaging the wire or wire shielding.

NOTE: The wiring configuration differs per model and individual facility requirements. Make the necessary adjustments that may be required to complete this procedure.

5. Locate the mounting plate (if applicable) and two mounting screws, for the cord and wire harness mounts, on the outside of the adjacent door rail.
6. Using a phillips-head screwdriver, loosen and remove each screw.
7. Carefully pull out and remove strain relief harness, as well as the loop terminal for the ground (green) wire.



8. Remove the wire terminals from the door rails.

NOTE: Two terminals adjoin the ends of the heater wire with the hot and neutral wires from the power cord. Two different methods can be used to disconnect the heater wire from the power cord.

9. Open the wire terminals and remove the terminated wire ends.



10. Locate the heater wire in the grooves of all four door rails. The heater wire is usually shielded with a woven fiberglass sleeve.
11. Using a flathead screwdriver, pull the heater wire out from door rails.



12. Manually pull out and remove the remaining heater wire.



13. Install the terminated wire ends from the replacement heater wire, then close the wire terminals.



NOTE: If the replacement heater wire does not have terminated ends, then splice the wires together using wire nuts or solder and heat shrink.

4.10.1. Splicing wire ends with solder and shrink tubing

1. Cut the (black and white) power wires, after the terminals.
2. Strip a minimum of 1/2" of insulation from each wire, exposing the end of the each cut wire.
3. Strip a minimum of 1/2" of insulation from each end of the heater wire.
4. Insert one, two inch heat-shrink tube (not supplied) over each end of heater wire.
5. Slide each tube down, away from the wire ends.
6. Join the exposed end of each stripped wire, from the power cord, with each end of the stripped heater wire.
7. Twist the wire ends together and solder the adjoined wire ends using a soldering iron, flux and solder.
8. Slide each heat-shrink tube back up the heater wire and over the soldered wire joints.
9. Using a heat gun, apply a steady flow of heated air onto each shrink tube, covering the soldered wire joints, to shrink the tubing and insulate the joints.
10. Insert the entire replacement heater wire into the groove inside the door rails and arrange the wire assembly to the same configuration that it had prior to disassembly.
11. Carefully re-install the wire assembly into the door rail and the power cord into strain relief by inserting the wire into the groove located along all four door rails by using a blunt tool or instrument, such as a screwdriver handle, in order to facilitate the insertion. Be certain to match the original wire installation configuration.
12. Replace plastic covers and gasket to the door.

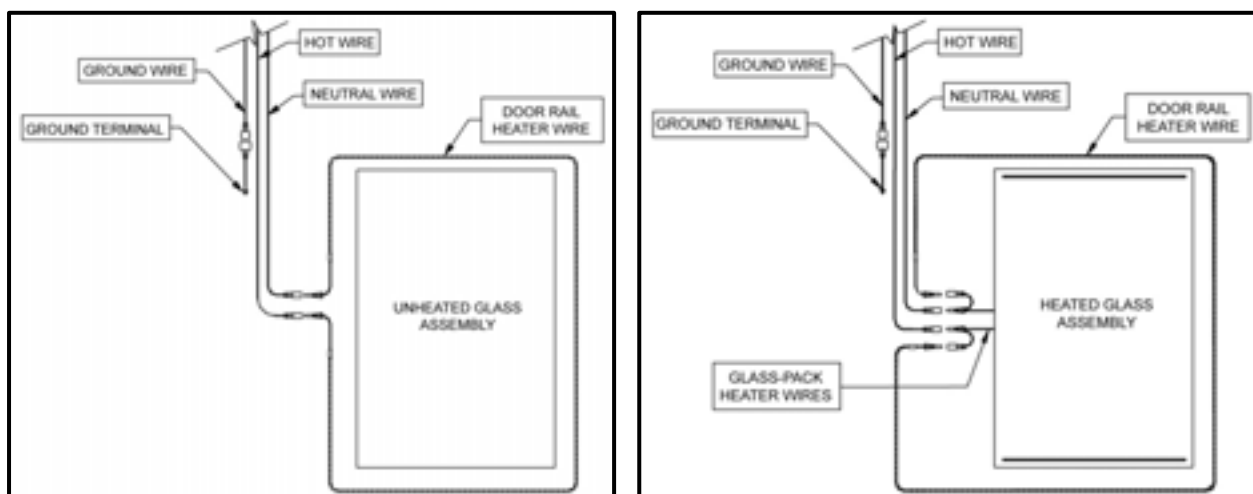

4.11. Removing and Replacing the Hinge Pin

1. With the access cover removed, pull the hinge pin wires out and separate all three wires (Hot, Neutral and Ground) from the door wire harness by carefully pulling the terminations apart.
2. Using a flat-head screwdriver, pry the hinge pin loose from the mount in the top door frame rail.
3. Pull the hinge pin out of the door frame until the pin and the wires are completely removed.



4. Upon replacing the hinge pin, insert all three wires into the hinge pin hole in the door rail.



5. Thread the wires through the rail to the access opening.



6. Connect the hinge pin wires to the terminated door wires.
7. Insert the remainder of the hinge pin into the frame mounting hole
8. Insert the remainder of the hinge pin into the frame mounting hole until the hinge pin is fully seated.
9. Harness wires together using a tie-wrap and insert the harness into the door rail and install the access cover.

10. Reassemble door by following the aforementioned reassembly instructions per section.

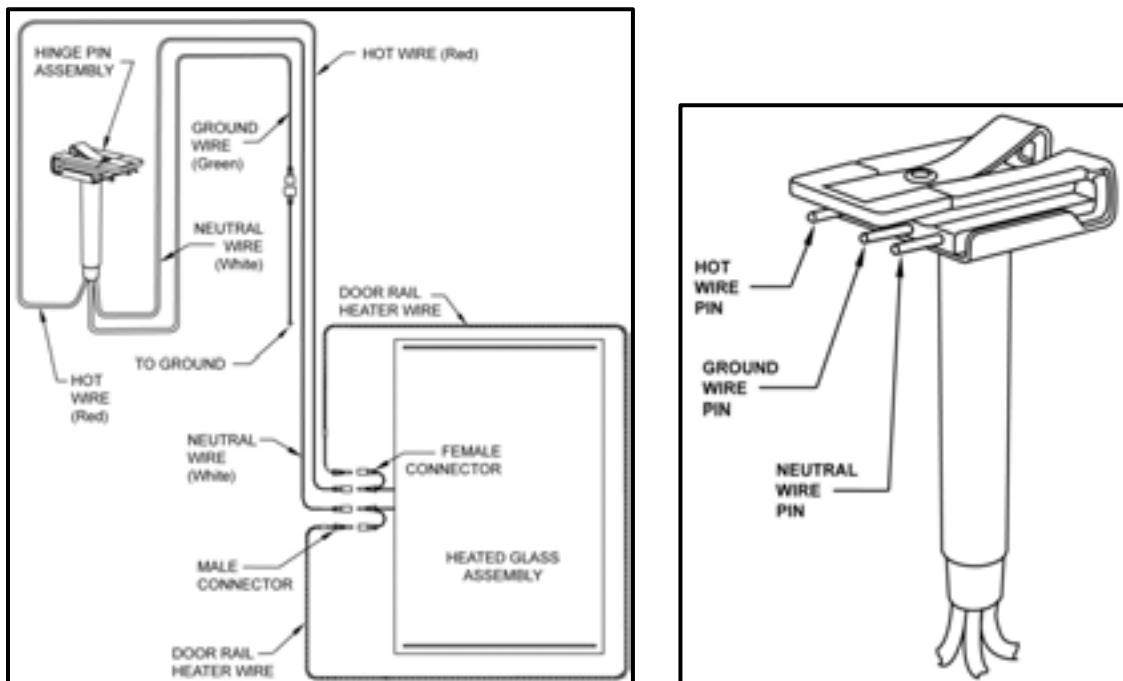

4.12. Glass Pack Replacement Procedures

1. Remove the door assembly from the hinge mounts.
2. Carefully place the door assembly on a flat, clean and elevated surface or table.
3. Remove the door gasket (refer to the gasket removal section for removal procedures).
4. Remove the plastic covers from the door rails (refer to the plastic cover removal section for proper removal procedures).
5. Remove the screws securing the access cover to the electrical wires and remove cover.
6. Carefully pull power wires from the door rail and locate the glass-pack heater wires.



7. Open each terminal housing, exposing the wire connections.

8. Remove the terminated wires from the terminals.

NOTE: The terminated wire ends of the glass pack wire may not be accessible. If so, skip step 7 and step 8 and proceed to step 9.

9. Carefully cut the glass-pack wires at least 1/2" inch from the glass pack assembly.

10. Using a sharp razor knife, carefully insert the knife blade in-between the glass-pack edge and the door rail.

11. Cut into the adhesive adjoining the glass pack to the door rail, and slice along the seam between the glass-pack edge and the rail.



12. Continue cutting the glass-pack away from all four door rails.



13. Confirm that the adhesive has been cut completely through, as well as all around the glass-pack.



14. Place a piece of thick foam block underneath the glass-pack, at each end of the door assembly.

15. Press down firmly on each corner of the door rail frame assembly to initiate the separation of the glass-pack from the door rail frame assembly.

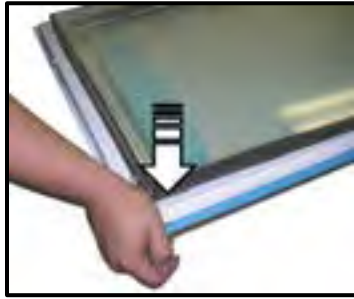

*** Procedure shown without gloves for clarity**

16. Once all four corners of the glass-pack have been loosened, go to one end of the door assembly and place one hand on each corner of the door rail frame assembly.



17. Press down firmly on both corners of the door rail frame assembly, forcing it down and separating the frame assembly from one end of the glass pack.

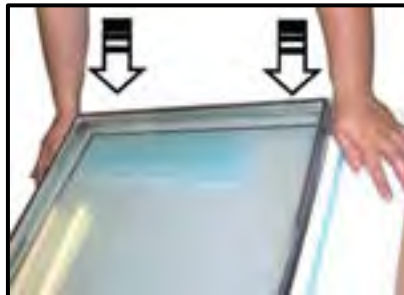

18. Go to the other end of the door assembly and repeat step 16 and step 17 to separate the other end of the glass-pack from the door rail assembly.
19. If necessary, stack two foam blocks atop one-another and work the door rail frame downward to facilitate a complete separation of the glass-pack from the door rail frame.

20. Carefully lift and remove the glass pack from the door rail assembly.

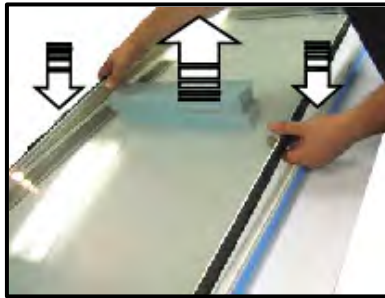

21. Remove foam blocks from the tabletop.
22. Install foam mounting tape along the interior of the frame assembly inside each rail.
23. Apply a thin strip of silicone adhesive to the interior of the door rail frame, alongside the foam tape.
24. Using extreme care, check and confirm that glass-pack heater wires are aligned with the power cord assembly in the door rail frame assembly. Be certain that the heater wires are away from the insertion point to avoid entangling the wires in the adhesive during installation.
25. Insert one side of the replacement glass package assembly into the corresponding side of the frame assembly.

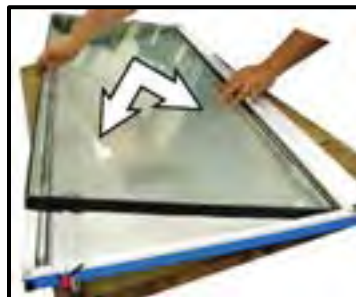

26. Gently insert the remaining side of the glass-pack into the inside of the rail frame assembly until the glass pack is completely inserted into the rail frame. If necessary, use a plastic or rubber mallet and gently tap the edges of the glass-pack into the rail frame assembly.



27. Replace any loosened spacers and confirm that all four sides of the glass-pack are fully inserted into the rail assembly and evenly distributed within the frame.

28. If glass-pack wires are terminated, insert the terminated wire ends into the terminals.
29. If the glass wire ends are stripped, then strip the cut wires from the power cord and join the wires using wire nuts.
30. If wire nuts are not an option, insert a two inch heat shrink tube over each stripped wire and slide the tubes away from the stripped wire ends.
31. Join the stripped wire ends from the power cord to the stripped heater wire ends and lightly twist.
32. Using a soldering iron or gun, solder the wire ends together.
33. Slide the heat shrink tubing over the solder joints of the adjoined wire ends and, using a heat gun, apply a steady flow of heated air onto each shrink tube to insulate the soldered wire joints.
34. Inject additional silicone adhesive into the seams between the glass-pack edges and the door rails.
35. Allow the silicone adhesive to cure.
36. Replace the plastic covers to the door rails (refer to plastic cover replacement procedures).
37. Replace the gasket to the door assembly (refer to gasket replacement procedures).
38. Install door assembly to the torquemaster (refer to door installation procedures).
39. Install door in frame gib and power receptacle (refer to door installation procedures).
40. Plug power cord into socket to restore power to the re-installed door assembly.

4.13. Ordering Replacement Doors

When ordering replacement doors, call Anthony International customer service at 800.772.0900 and specify to the representative the need to order a replacement door. Be sure to provide all of the information and specifications that are required for ordering replacement doors (refer to diagram for the complete door ordering configuration):

- Measure and specify the width (**A**) of the door to the nearest 1/16”.
- Measure and specify the height (**B**) of the door to the nearest 1/16”.
- Furnish the date of the original order or the Anthony invoice number. (The original manufacturing date will be stamped on the spacer bar, between panes of glass (**C**)).
- Specify whether or not the replacement door will require a heated glass-package.

- Which way does the door hinge (left or right), as well as the type of hinge, will need to be specified.
- The Anthony representative will also need to know if the replacement door is for a cooler or a freezer.
- The need for door locks and installation hardware must be specified.
- The correct electrical voltage is required for the order.
- Are there any custom items with the original order? If so, please specify them as well as the details of those items.
- Work Order Number from Data Tag (if present **(D)**).

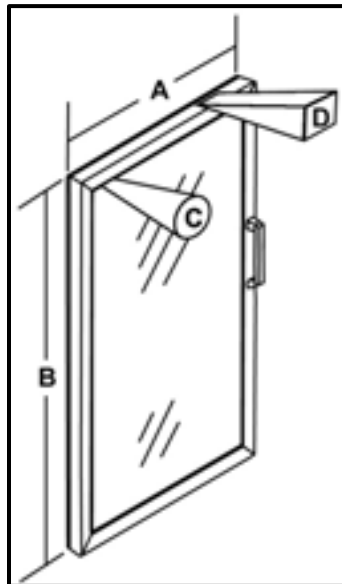

5. REPLACEMENT DOOR INSTALLATION

5.1. Installing the Door Assembly into the 101X Frame

1. If replacing the Torquemaster, insert it with the hollowed end towards the frame corner. Align the mounting flanges on the bottom of the torquemaster with the divots in the corners of the mounting hole

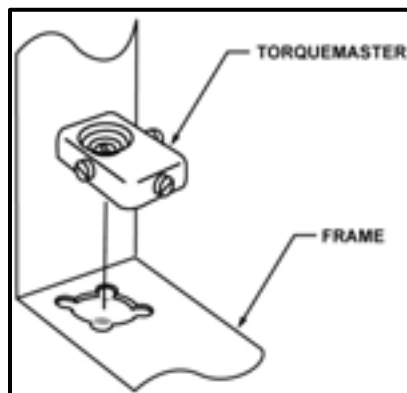

- Using a flat-head screwdriver, turn the Torquemaster mounting screw clockwise to tighten the mount. Confirm that the torquemaster mounting is flush with the door frame.



- Handling the door carefully, install it into the frame by inserting the torque rod-end into the cavity of the Torquemaster.



- Tilt the top of the door up and toward the frame, inserting the hinge pin into the Gib, located in the top of the door frame.



- Extend the hold-open device toward the mounting hole in the top frame rail.
- Insert the hold-open bolt through the elongated hold-open slot.

7. Install the washer and the hold-open bolt into the frame mounting hole and tighten the bolt.



NOTE: Do not over-tighten the hold-open bolt. Be certain the hold-open does not bind while sliding along the hold-open bolt. Adjust as necessary.

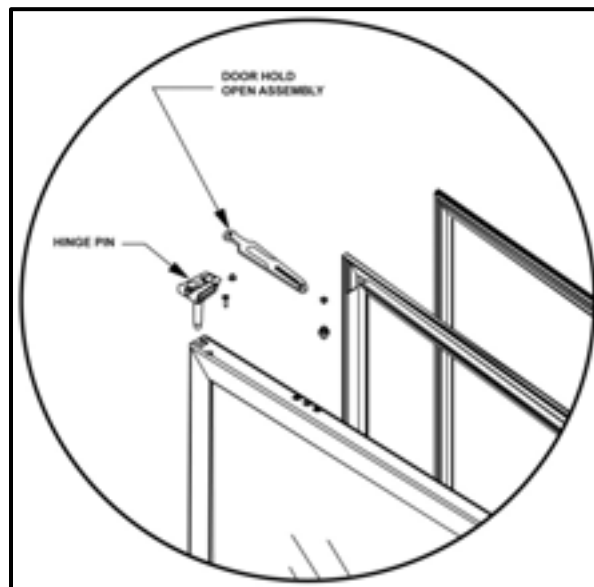

5.2. Torque and SAG Adjustment



The Torquemaster is the component into which the door is hinged, at the bottom torque rod. The Torquemaster regulates the speed and tension of the door swing, as well as the angle at which the door is mounted.

1. Using a flat-head screwdriver, turn the outside screw to adjust the torque rod tension on the Torquemaster.
 - Turn the screw counter-clockwise to increase the tension.
 - Turn the tension screw clock-wise to decrease the tension.



2. To adjust the door sag, or square it in the frame, use the flathead screwdriver to change the setting on the screw that is marked SAG ADJ. (Sag Adjustment), located on the end of the Torquemaster.
 - Turn the screw clockwise to lower the handle side of the door.
 - Turn the screw counter-clockwise to raise the handle side of the door.

6. FRAME MAINTENANCE & PARTS REPLACEMENT

6.1. Torque Replacement

1. Using a large slot-head or flat-head screwdriver, loosen the installation mounting screw located in the center of the torque rod mounting socket of the Torquemaster.



2. Remove the Torquemaster from the frame mount.
3. Replace the Torquemaster to the mount located on the frame.
 - If necessary, remove the plug cap located on the lower frame near the corner. Be certain to remove the plug cap that correlates with the side of the frame in which the door is to be installed.



4. Place the Torquemaster on the newly opened mounting pocket in the frame, with the hollowed end of the Torquemaster towards the frame.
5. Align the mounting flanges on the bottom of the Torquemaster with the divots or slots in the corners of the mounting hole. Be certain the Torquemaster is fully seated onto the frame.



6. Turn the mounting set-screw clockwise to engage the mounting mechanism underneath the frame lining, and confirm that the Torquemaster is securely mounted.

NOTE: To adjust the Torquemaster settings, refer to the Torquemaster and Door Sag adjustment procedures.

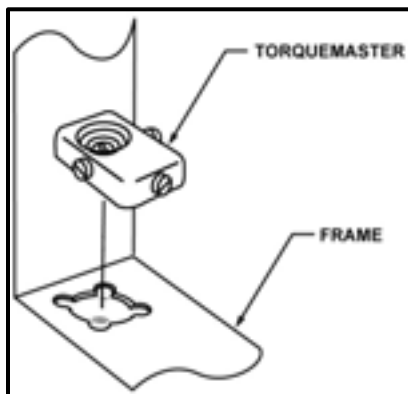

6.2. Power Receptacle Replacement

1. Carefully peel and remove the foam tape securing the wire leads to the power receptacle.



2. Using a #2 phillips-head screwdriver, remove the screws securing the receptacle to the top frame.

3. Remove the receptacle and slowly pull the connected wires out, away from the frame.



4. Disconnect the receptacle wires from the frame wires by separating the quick-connectors or, using wire cutters, cut the wire connections between the receptacle and the frame, leaving ample slack with the spared end of the wires.
 - Single Receptacles are composed of three wires:
 - ① WHITE is the neutral wire
 - ② GREEN is the Ground wire
 - ③ Red is the hot wire
 - Double Receptacles utilize two sets of the same three wires. These receptacles are located by the center mullions and are.
5. Thread the wires for the replacement receptacle into the frame.
6. Mate each socket conductor lead with the newly stripped leads to the frame wiring.

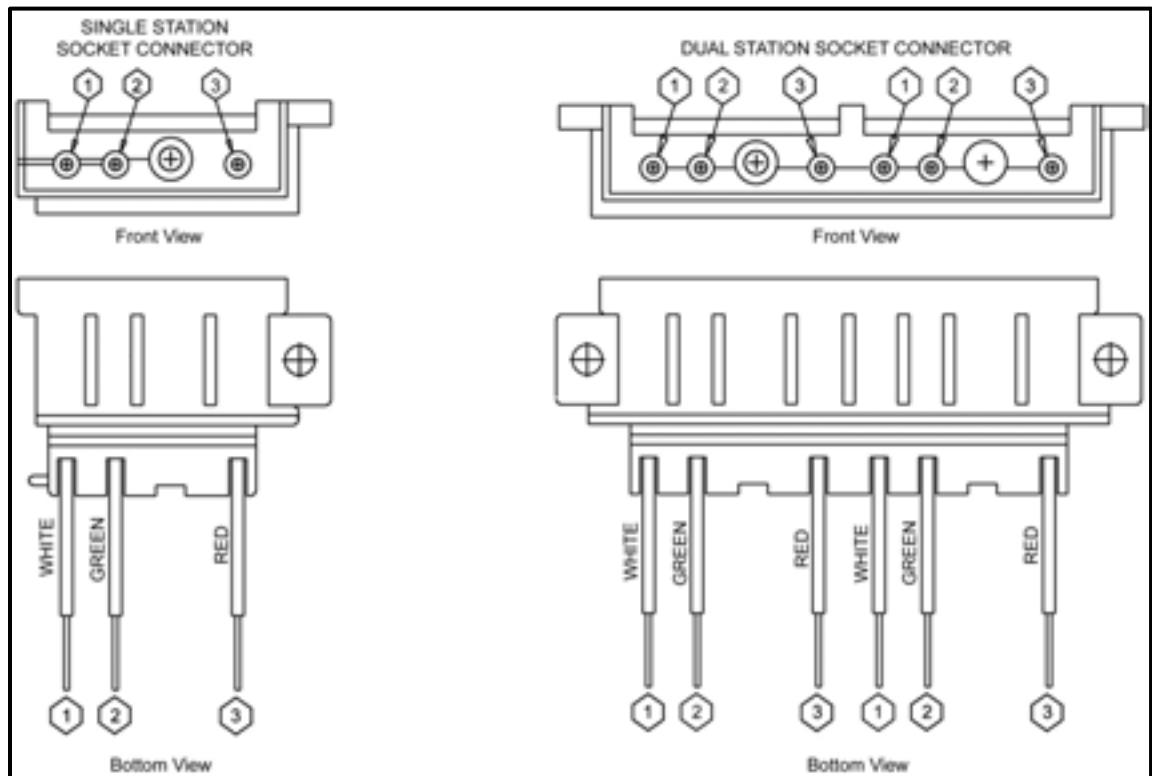

7. Join the replacement wires with the frame power wires by plugging the quick-connectors together, or by mating each stripped socket lead wire with the correlating frame wire lead and slightly twist the wire leads together.
8. Insert the joined eighteen gauge (18 AWG) leads into compatible wire nuts and twist the wire nuts until the leads are securely joined.
9. A Butt Splice can also be used as another method of adjoining the wires.
 - Insert each stripped wire end into the butt splice tube.
 - Crimp tube firmly until both wires are securely joined.
10. Carefully place the wire assembly back into the frame and reassemble the contact plates and zipper strips.

6.3. Frame Heater Wire Replacement (see Section 8 for Wiring Diagrams)

If the heater wire requires servicing or replacement, perform the following tasks.

1. With the contact plates removed from the frame mullion and frame rails, locate the heater wire in the frame.

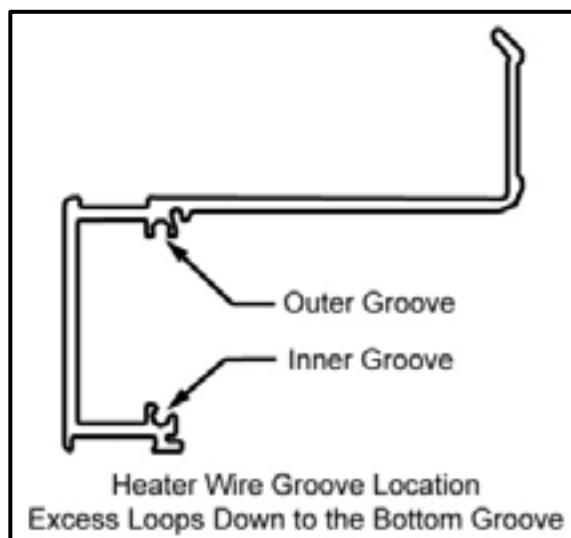

2. Disconnect the wires at the connectors or cut the wires using wire cutters.
3. Carefully dislodge the heater wire from the groove mounts along the frame rails and remove the wire. The heater wire is usually shielded with a woven fiberglass sleeve.
4. Carefully pull out and remove the strain relief harness as well as the loop terminal for the ground (green) wire.

NOTE: Two terminals adjoin the ends of the heater wire with the hot and neutral wires from the power cord. If the heater wire must be cut in order to be disconnected, refer to the 'Splicing Wire Ends' of the door heater wire section for replacement instructions.

5. Open the wire terminals and remove the terminated heater wire ends.

6. Install the terminated wire ends from the replacement heater wire, then close the wire terminals.



7. Lay the replacement wire out in a fashion that will avoid knots and tangling during re-installation into the frame.
8. Using a screwdriver handle or a putty knife, insert the entire replacement heater wire into the groove inside the frame and arrange the wire assembly to the same configuration that it had prior to disassembly.



9. Replace contact plates and reassemble frame as required.

NOTE: If the replacement heater wire does not have terminated ends, splice the wires together.

6.4. Driver Replacement

The drivers are located in the center mullions and top frame rails. In the event of driver failure or upgrade, perform the following procedures to replace the drivers.

- 1 Turn the frame light switch OFF or disconnect power to the frame.
- 2 Remove the zipper strips and the contacts plates covering the frame or mullion raceway, as outlined in the frame disassembly section.
- 3 Each mullion or frame section contains more than one driver. Locate the driver in need of replacement.
4. Unplug the lower, eight (8) pin connector by pressing down on the connector latch and gently pulling the two connectors apart.

5. Unplug the upper three (3) pin connector by pulling the pin and receptacle plugs apart.
6. Using a phillips-head screwdriver, loosen the screw securing the lower portion of the driver to the raceway.
7. Hold the driver in place then loosen and remove the screw securing the top of the driver and remove the driver from the frame. Set the screws aside for reuse.
8. Place the replacement driver in the raceway in the same configuration that the removed driver was in, prior to its removal, with the bottom driver flange inserted beneath the lower screw.
9. Align the driver top mounting hole with the mounting hole in the raceway and tighten the lower screw.
10. Insert the top mounting screw and tighten using a phillips-head screwdriver, until the top of the driver is nearly (but not completely) secure.
11. Tighten the lower mounting screw to secure the bottom of the driver.
12. Using a phillips-head screwdriver, tighten the top screw, securing the upper portion of the driver until the driver is totally secure.
13. Re-acquire the three (3) pin conductor push-wire connector and mate it with the three (3) pin plug connector from the replacement driver.
14. Insert all three pins from the male plug into the three female connector receptacles until the male plug snaps into place.
15. Re-acquire the female eight (8) pin frame connector and mate it with the eight (8) pin male connector from the replacement driver.
16. Insert all of the pins from the male plug into the eight female connector receptacles until the male plug snaps into place or is secure.

NOTE: Some replacement drivers differ in size to the original. Refer to the Product Update Bulletins in “Appendix A-1 thru A-3; Alternate Driver Mounting”.

NOTE: Some replacement drivers require adapters for the pin connectors.

#24	2-light	(1-door)
#24a	3-light	(2-door)
#24b	4-light	(3-door)
#24c	5-light	(4-door)
#24d	6-light	(5-door)

Recommended New Driver Lead Wires

6.5. Frame Reassembly

1. Place the contact plate over the frame or mullion raceway.



2. Align the contact plate in the center of the raceway.



3. Place one end of the zipper strip in the corner of the frame and press it in until it snaps into place.



4. Pressing the contact plate firmly against the frame raceway cover, slide along the frame corner, inserting the remaining zipper strip into the groove adjoining the contact plate to the frame rail or mullion.
5. Confirm that the entire zipper strip is completely inserted over the frame corner.

6. If necessary, use a plastic or rubber mallet to facilitate the zipper strip installation by tapping the zipper strip into place.



7. TROUBLESHOOTING

Door & Frame

I. Glass condensation	a. No power	<ol style="list-style-type: none"> 1. Check power supply 2. Check humidity controller 3. Check hinge pin connections 4. Check glass wire connections 5. Check hinge pin wiring
	b. Low voltage	<ol style="list-style-type: none"> 1. Check main voltage 2. Check humidity controller
II. Door/Frame rail condensation	a. No power III. Door not closing or sealing	<ol style="list-style-type: none"> 1. Check power supply 2. Check humidity controller 3. Check hinge pin connections 4. Check door wire connections 5. Check frame wire connections 6. Check
	b. Low voltage	<ol style="list-style-type: none"> 1. Check main voltage 2. Check humidity controller hinge pin
	c. Door seal malfunction Refer to Door not closing or sealing”	<ol style="list-style-type: none"> 1. Check gasket 2. Check door mount wiring
III. Door not closing or sealing	a. Gasket malfunction	<ol style="list-style-type: none"> 1. Check gasket installation 2. Check gasket for damage 3. Replace gasket
	b. Door not closing properly	<ol style="list-style-type: none"> 1. Check hold-open 2. Check TorqueMaster torque 3. Check TorqueMaster mount 4. Adjust TorqueMaster sag 5. Check frame/door square 6. Check plastic covers on rails

IV. Door saw-toothed	a. Door or frame not square	<ol style="list-style-type: none"> 1. Square door to 1/16" 2. Adjust TorqueMaster sag 3. Replace worn hinge pin socket 4. Facility or case not level 5. Frame not properly shimmed 6. Hold-open binding/damaged
V. Lamp inoperative	a. Power switch OFF	Turn power switch ON
	b. Lamp burned-out	Replace lamp
	c. Lamp socket failure	<ol style="list-style-type: none"> 1. Check socket mounting 2. Check socket/lamp connection 3. Check ground wire connection
	d. Incorrect lamp	Replace with correct lamp
	e. Driver failure	<ol style="list-style-type: none"> 1. Check wire connections 2. Replace driver
	f. Incorrect driver	Replace driver
	g. Incorrect wiring	<ol style="list-style-type: none"> 1. Check ground wire connection 2. Reconfigure wiring 3. Replace wiring
VI. Lamp intermittent or dim	a. Incorrect voltage	<ol style="list-style-type: none"> 1. Match lamp voltage to circuit 2. Match driver to circuit voltage
	b. Socket failure	<ol style="list-style-type: none"> 1. Check lamp-socket connection 2. Check socket wiring
	c. Lamp cover failure	<ol style="list-style-type: none"> 1. Check cover installation 2. Check mullion lens installation 3. Replace lamp cover
	d. Defective wiring	Check & replace wiring
	e. Defective lamp	Replace lamp
	f. Defective driver	Replace driver
VII. Lamp start-up too slow	a. Defective lamp	Replace lamp
	b. Lamp cover failure	<ol style="list-style-type: none"> 1. Check cover installation 2. Check mullion lens installation 3. Replace lamp cover
	c. Incorrect voltage	Match lamp voltage to circuit
	d. Defective driver	Replace driver
VIII. Lamp life too short	a. Incorrect wiring	Check & replace wiring
	b. Incorrect voltage	Match lamp voltage to circuit
IX. Driver noise	a. Defective driver	Replace driver
	b. Loose driver cover	Repair or replace driver
	c. Driver mount incorrect	Remount driver correctly

8. DOOR & FRAME ELECTRICAL SPECIFICATIONS

8.1. Typical Heater Wire and Lighting Wiring Diagrams

8.1.1. Zero Zone 101X, 210X and ELM LT/NT Frames

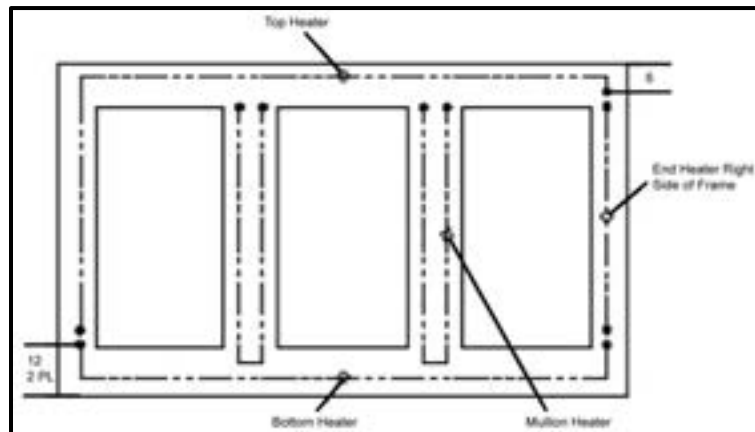

CIRCUIT	HOT	NEUTRAL
LIGHTS	BLK	BRN
TOP & BTM HTR	PUR	WHT/PUR
MULLION HEATER	RED	WHT/RED
END HEATER	PUR/YEL	WHT/YEL
DOORS	ORG	WHT/ORG
GROUND	GRN/YEL	

Notes: Unless otherwise specified

1. Heater wire routing for Zero Zone 101X, 210X, and ELM LT/NT frames, all door sizes.
2. Wire lead colors.
3. Wire labels are not required.

Note 2 & 3 applicable for all Zero Zone frames.

8.1.2. Zero Zone Low Energy 101X, 210X and ELM LT Frames

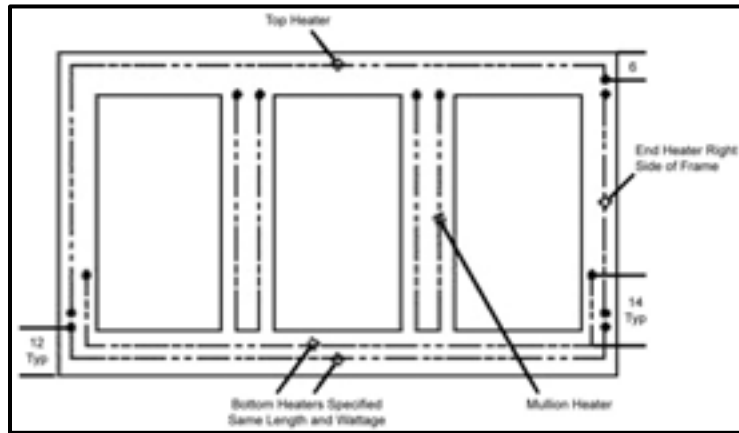

CIRCUIT	HOT	NEUTRAL
LIGHTS	BLK	BRN
TOP & BTM HTR	PUR	WHT/PUR
MULLION HEATER	RED	WHT/RED
END HEATER	PUR/YEL	WHT/YEL
DOORS	ORG	WHT/ORG
GROUND	GRN/YEL	

Notes: Unless otherwise specified

1. Heater wire routing for Zero Zone Low Energy 101X, 210X, and ELM LT frames, door size 29-7/8.
2. Wire lead colors.
3. Wire labels are not required.

Note 2 & 3 applicable for all Zero Zone frames.

8.1.3. Zero Zone 101X, 210X and ELM LT Frames

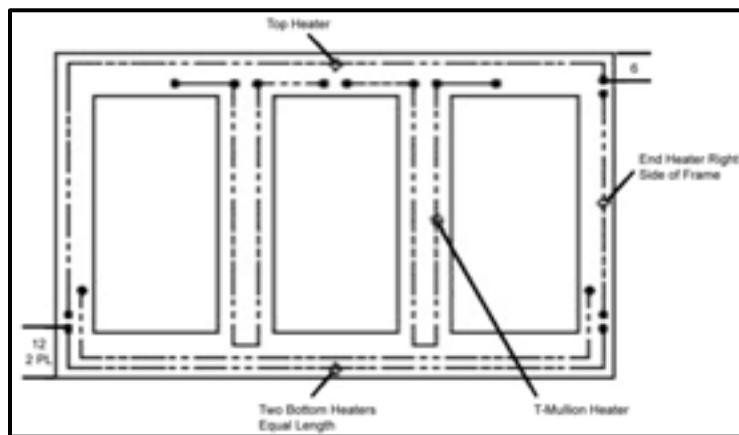

CIRCUIT	HOT	NEUTRAL
LIGHTS	BLK	BRN
TOP & BTM HTR	PUR	WHT/PUR
MULLION HEATER	RED	WHT/RED
END HEATER	PUR/YEL	WHT/YEL
DOORS	ORG	WHT/ORG
GROUND	GRN/YEL	

TITLE:

Notes: Unless otherwise specified

1. Heater wire routing for Zero Zone Low Energy 101X, 210X, and ELM LT frames, door size 29-7/8.
2. Wire lead colors.
3. Wire labels are not required.

Note 2 & 3 applicable for all Zero Zone frames.

101X

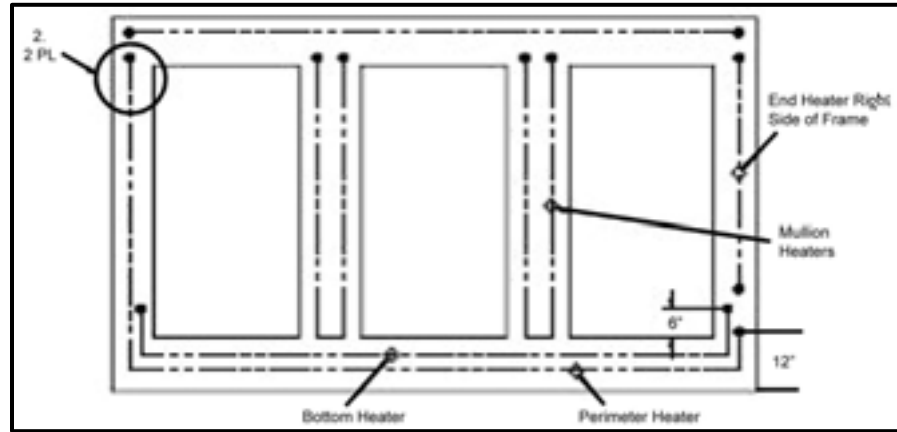

Notes: Unless otherwise specified

1. Top heater to be installed before door sockets are set in place..
2. Bond heater wire to the bottom of the aluminum raceway where the heater wire crosses from the inside raceway groove to the outside groove.

8.1.4. Zero Zone 101X and 210X NT Frames

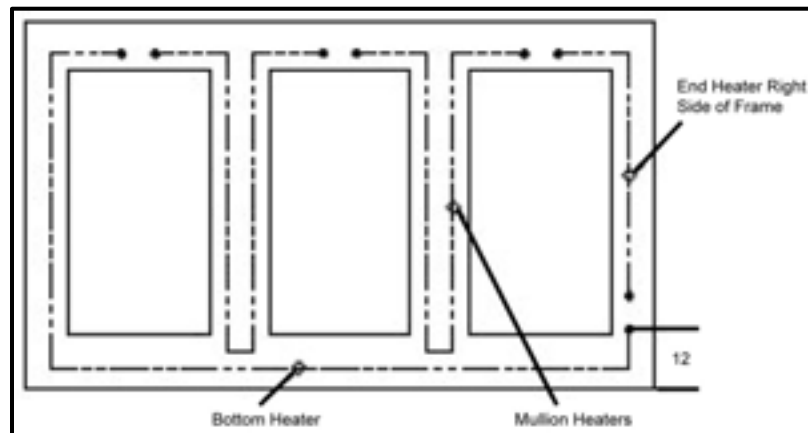

CIRCUIT	HOT	NEUTRAL
LIGHTS	BLK	BRN
TOP & BTM HTR	PUR	WHT/PUR
MULLION HEATER	RED	WHT/RED
END HEATER	PUR/YEL	WHT/YEL
DOORS	ORG	WHT/ORG
GROUND	GRN/YEL	

Notes: Unless otherwise specified

1. Heater wire routing for Zero Zone 101X and 210X NT frames, All door sizes.
2. Wire lead colors.
3. Wire labels are not required.

Note 2 & 3 applicable for all Zero Zone frames.

8.2. Anthony Door Model 101 Optimax Pro 24 Wiring Diagram & Orientation

NOTE: Zero Zone frame wires exit at the bottom right of the frame.

CIRCUIT	HOT	NEUTRAL
LIGHTS	BLK	BRN
TOP & BTM HTR	PUR	WHT/PUR
MULLION HEATER	RED	WHT/RED
END HEATER	PUR/YEL	WHT/YEL
DOORS	ORG	WHT/ORG
GROUND	GRN/YEL	

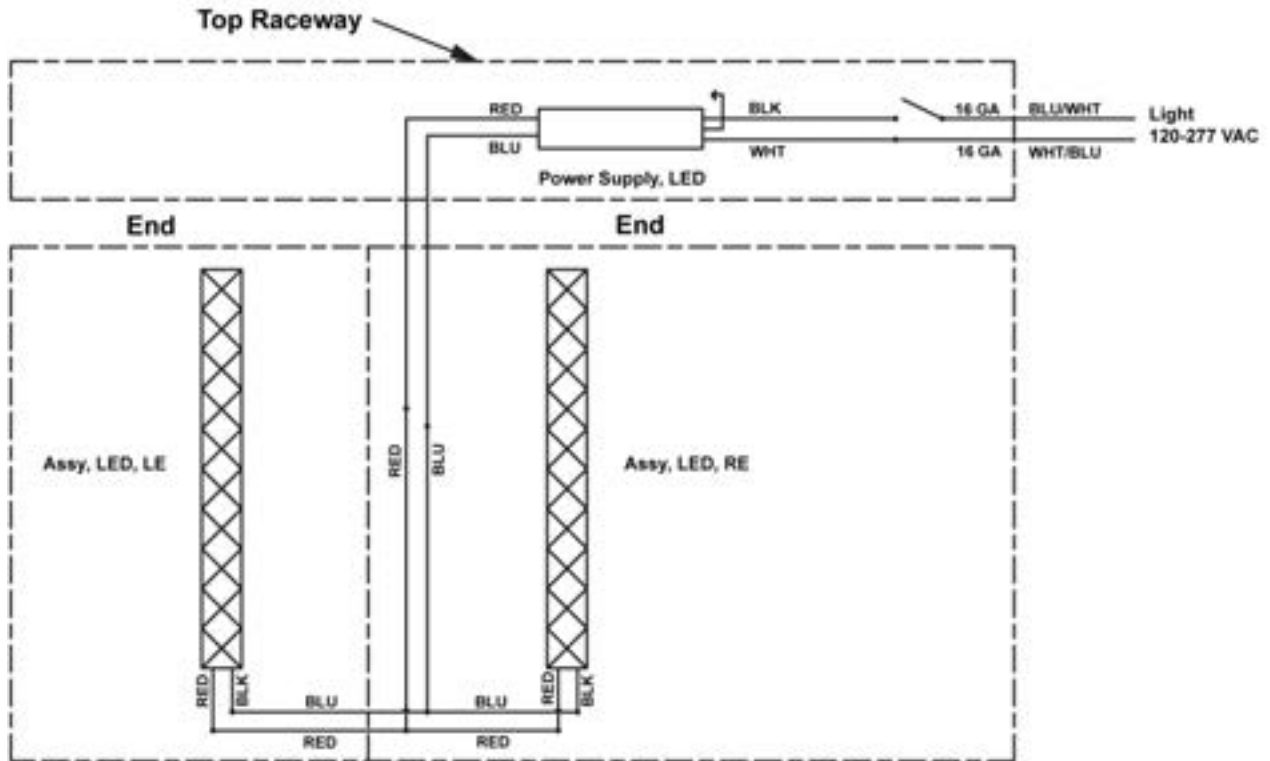

Wiring Diagram (07-19808-0001), 24V, Optimax Pro, (One Door)

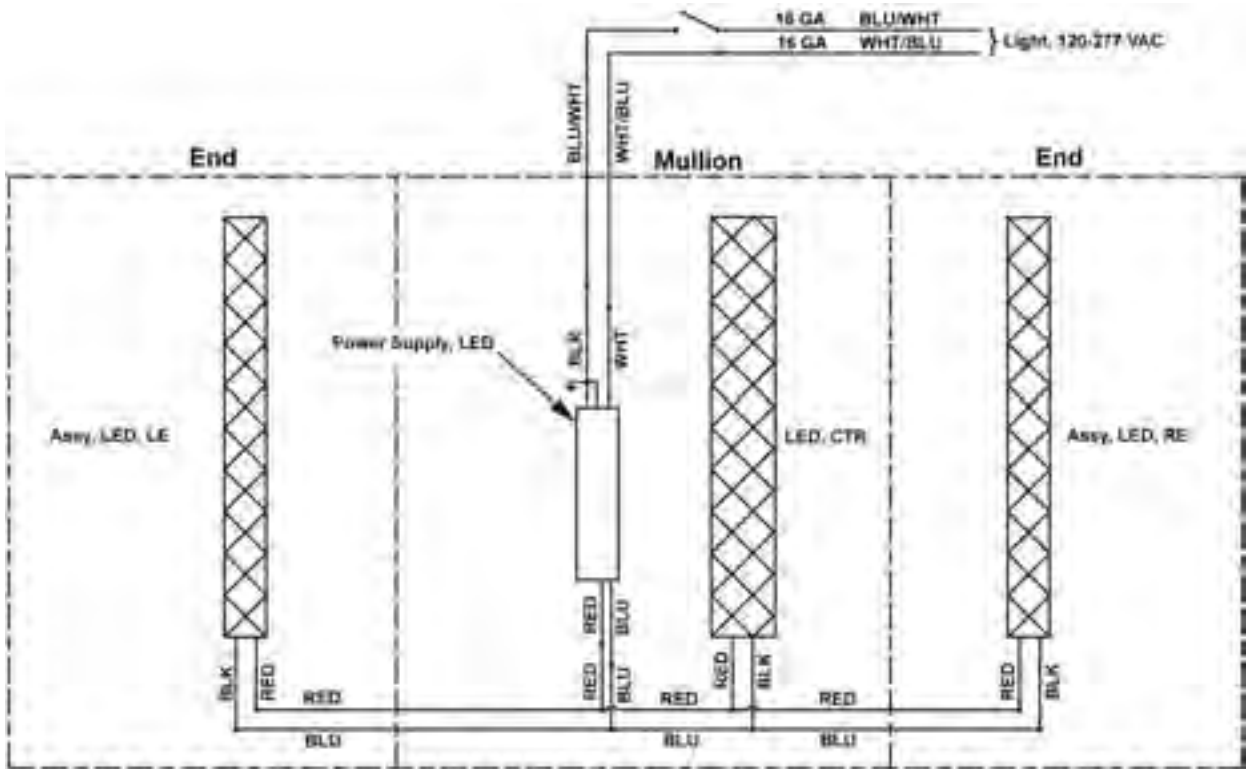

Wiring Diagram (07-19808-0002), 24V, Optimax Pro, (2-Door)

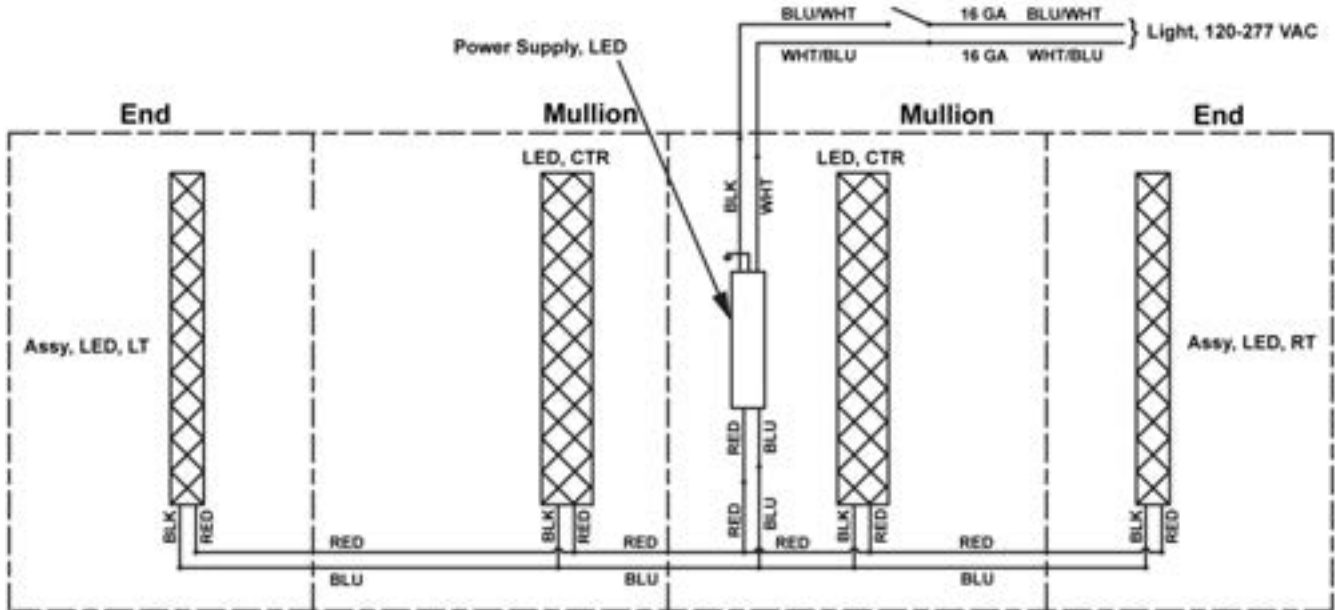

Wiring Diagram (07-19808-0003), 24V, Optimax Pro, (3-Door)

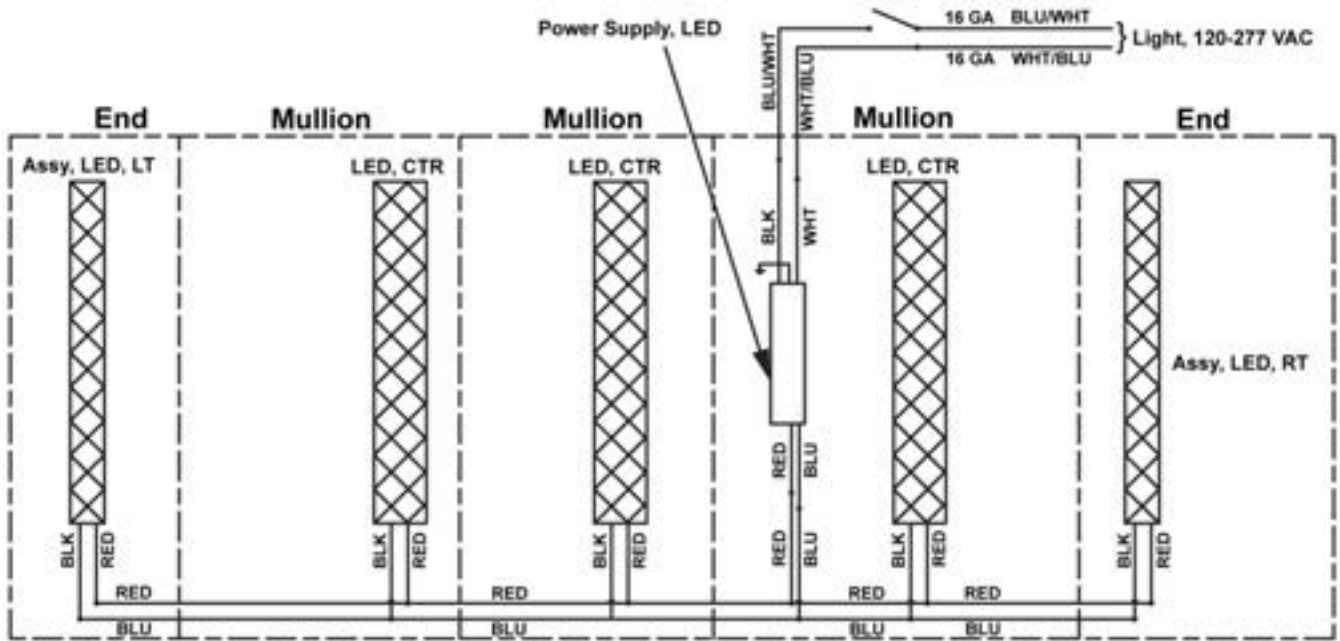

Wiring Diagram (07-19808-004), 24V, Optimax Pro, (4-Door)

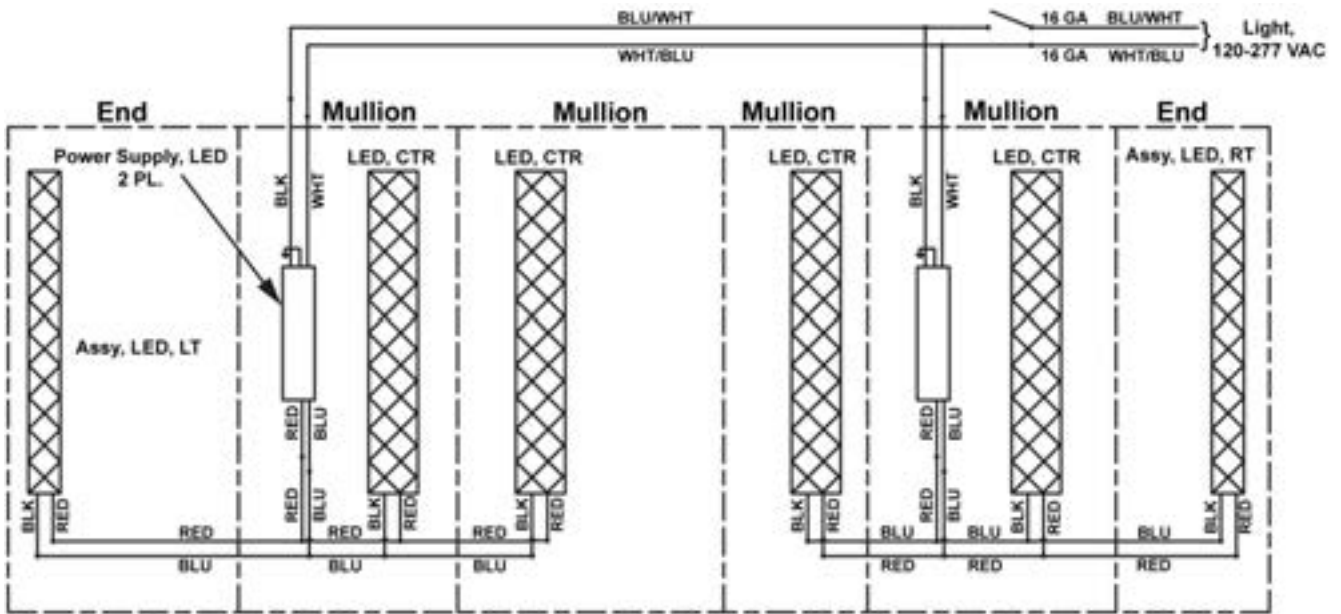

Wiring Diagram (07-19808-005), 24V, High Power, Optimax Pro, (5-Door)

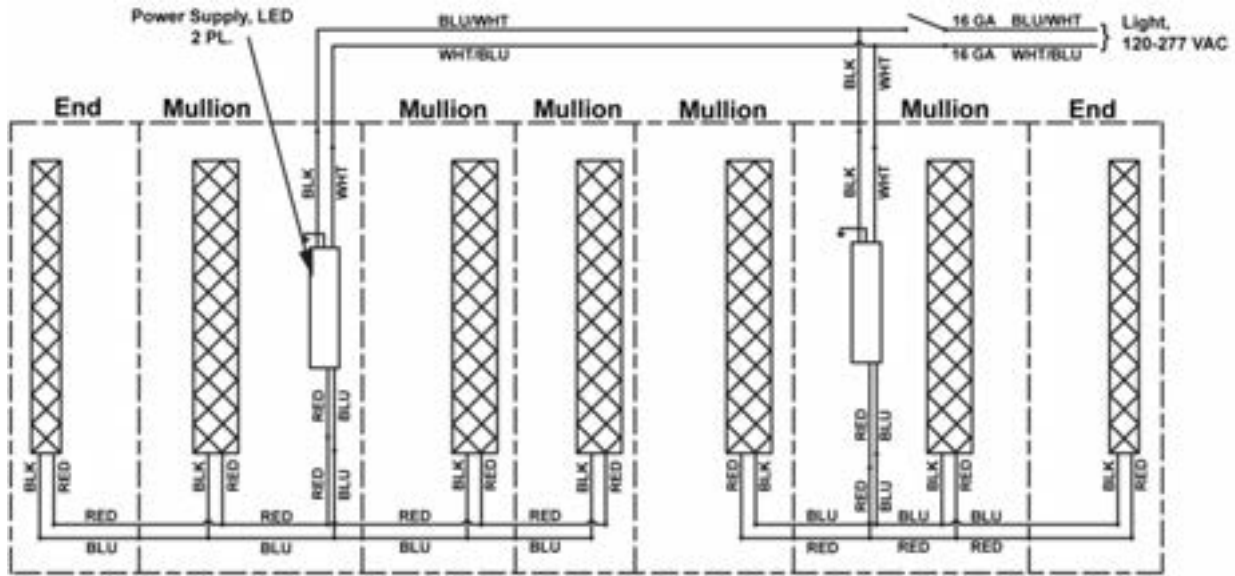

Wiring Diagram (07-19808-0007), 24V, High Power, Optimax Pro, (6-Door)

8.3. Dew Point Chart

Model 101 NT & LT

(1" Glass pack)

Dew Point Chart

Normal Temperature Applications

Glass Type	Room Temp (F)	Case Temperature (F)				
		40	35	30	25	20
TWO PANE NHG*	70	69	65	61	58	55
	75	66	62	59	55	52
	80	63	59	56	53	50
	85	60	57	54	51	48
	90	57	55	52	49	47
THREE PANE NHG*	70	74	71	68	65	62
	75	71	68	65	63	60
	80	69	66	63	61	58
	85	66	64	61	59	57
	90	64	62	60	57	55
TWO PANE REFLECTIVE NHG*	70	77	74	71	68	65
	75	75	72	69	66	63
	80	72	70	67	64	61
	85	70	67	65	62	59
	90	68	65	63	60	58
TWO PANE HEATED GLASS	70	98	94	89	84	80
	75	93	89	84	80	76
	80	89	85	80	76	73
	85	85	81	77	73	70
	90	81	77	74	70	67

*NHG = Non-Heated Glass

% Rel Humidity @ which Condensation Forms on Glass

Low Temperature Applications

Glass Type	Room Temp (F)	Case Temperature (F)						
		+5	0	-5	-10	-15	-20	-25
3-PANE HEATED REFLECTIVE NHG*	70	85	82	80	77	75	73	70
	75	82	80	77	75	73	71	69
	80	80	78	75	73	71	69	67
	85	78	75	73	71	69	67	66
	90	76	74	72	70	68	66	64
% Rel Humidity @ which Condensation Forms on Glass								

Calculations make no allowance for air leaks or unusual air flow patterns within cases and are intended to be used only as a guideline.

9. SUPPLEMENTAL HANDLE REPLACEMENT INSTRUCTIONS

When accessing the internally mounted door fasteners, interference with the fastener's socket heads may be encountered. When attempting to loosen or remove the fasteners, located inside the door rail, the obstruction should be circumvented or removed from the path of access.

9.1. Preliminary Considerations

The tools and materials required to perform this procedure are:

- Power Drill
- 5/16" Drill Bit
- 5/32" Hex Key or Allen Wrench
- Soapy water or mild lubricant
- Flathead Screwdriver
- Plastic or Rubber Mallet

Safety practices must be observed. Always exercise caution when working with both sharp edged and powered tools.

9.2. Perform the following steps to remove the door handle mounting fasteners.

1. Remove Gasket:

- a. Starting at one corner of the door, carefully lift the corner of the magnetic gasket.
- b. Gently pull up the gasket along the rail and plastic cover.



- c. Pull out gasket completely and set gasket aside.

Note: Be sure to handle the gasket carefully to prevent damaging it.

2. If the plastic is not pre-drilled with access holes, remove plastic rail cover on the handle side of the door only.
 - a. Insert flathead screwdriver in between plastic cover, corner miter and carefully pry it upwards.
 - b. Lift and remove plastic cover (once again- on door rail of handle side only).



3. Clear obstructive matter from the fastener heads.

Note: Perform the following tasks with extreme caution to avoid damaging the fastener socket-head, as well as the door glass.

- a. Using a power drill with 5/16" drill bit, carefully insert the bit into the access hole of the door rail.
- b. Confirm that the drill aim is perpendicular to the rail and door.
- c. Gently apply power to the drill, spinning the bit at a low speed, while applying pressure to the obstruction, until the obstruction is cleared from the socket-head.

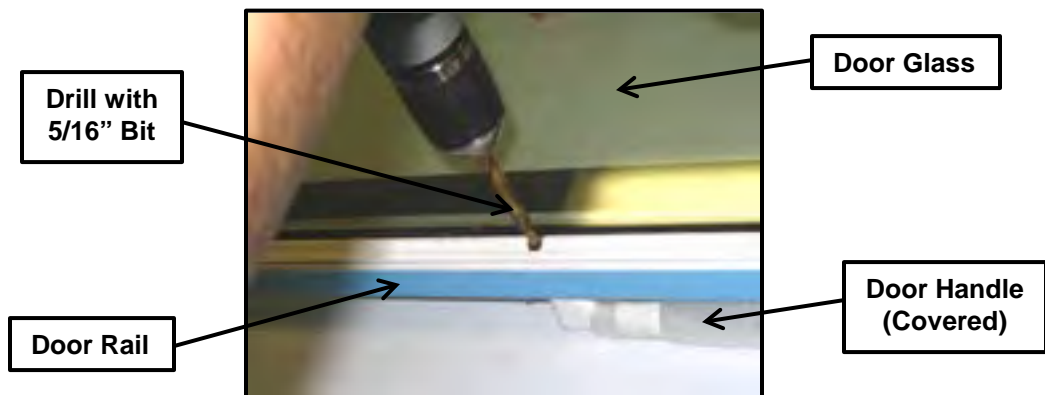

- d. The obstruction is composed of a reasonably soft material and should clear away relatively easy. **DO NOT** drill into the socket head.

Note: In the event that adhesive has settled inside the socket-head, use a 3/16" drill bit to carefully route the adhesive out of the socket head. **DO NOT** strip the hex pattern within the socket head.

4. Remove and replace the handle fasteners from the rail.
 - a. Once the obstructing matter has been cleared, insert a 5/32" hex key or allen wrench into the socket head of the handle fastener, and twist it counter-clockwise to loosen the fastener and remove it.



- b. Once the fasteners have been removed, replace with **NEW** socket-head fasteners. Using the same fasteners to secure the door handle is **NOT** recommended.
5. Reassemble the door rail gasket.
 - a. Replace plastic cover to the door rail.
 - b. Insert the inside edge of the plastic cover into the inside groove of the rail.
 - c. Push the plastic cover outward, away from the center of the door, in order to insert the outer lip into the outside groove of the rail.

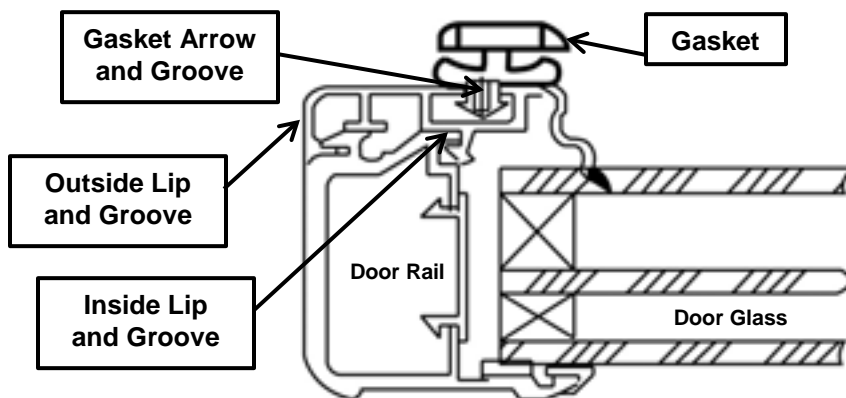

- d. Replace the gasket to the plastic cover.



- e. Insert the gasket arrow into the groove in the center of the plastic cover until the edges of the arrow catch and are fully inserted into the groove.
- f. Press the gasket firmly against the plastic cover and (pressing hard) slide along the gasket, inserting the remainder of the gasket arrow into the plastic cover groove.
- g. Using the blunt side of a plastic or rubber mallet, strike the gasket onto the cover and rail to facilitate the gasket arrow into the groove of the plastic cover.

Note: If the gasket arrow is exhibiting difficulty when being reinstalled into the plastic cover groove, apply soapy water or a mild silicone based lubricant to the gasket in order to assist in inserting the gasket arrow into the groove of the plastic cover.

10. REVISION HISTORY PAGE

REV	ORIGINATOR	DESCRIPTION OF CHANGE	EFFECTIVE DATE
A	SWatstein	Update format, logo & fonts	28 September 2010
B	SWatstein	Update format	01 February 2011
C	S. Fisher	Reformat from Framemaker to Word, remove fluorescents and add Optimax Pro 24	24 July 2013



12391 Montero Street, Sylmar, CA 91342
800.772.0900 www.anthonyintl.com

99-18544-S001_C